

Exhibit D

Environmental Protection Agency, RISK ASSESSMENT
EVALUATION FOR CONCENTRATED ANIMAL FEEDING
OPERATIONS, EPA/600/R-04/042 (May 2004)

Risk Assessment Evaluation for Concentrated Animal Feeding Operations



Risk Management Evaluation For Concentrated Animal Feeding Operations

U.S. Environmental Protection Agency
Office of Research and Development
National Risk Management Research Laboratory
Cincinnati, Ohio

[This Page Intentionally Left Blank]

Foreword

The U.S. Environmental Protection Agency (EPA) is charged by Congress with protecting the Nation's land, air, and water resources. Under a mandate of national environmental laws, the Agency strives to formulate and implement actions leading to a compatible balance between human activities and the ability of natural systems to support and nurture life. To meet this mandate, EPA's research program is providing data and technical support for solving environmental problems today and building a science knowledge base necessary to manage our ecological resources wisely, understand how pollutants affect our health, and prevent or reduce environmental risks in the future.

The National Risk Management Research Laboratory (NRMRL) is the Agency's center for investigation of technological and management approaches for preventing and reducing risks from pollution that threaten human health and the environment. The focus of the Laboratory's research program is on methods and their cost-effectiveness for prevention and control of pollution to air, land, water, and subsurface resources; protection of water quality in public water systems; remediation of contaminated sites, sediments and ground water; prevention and control of indoor air pollution; and restoration of ecosystems. NRMRL collaborates with both public and private sector partners to foster technologies that reduce the cost of compliance and to anticipate emerging problems. NRMRL's research provides solutions to environmental problems by: developing and promoting technologies that protect and improve the environment; advancing scientific and engineering information to support regulatory and policy decisions; and providing the technical support and information transfer to ensure implementation of environmental regulations and strategies at the national, state, and community levels.

This publication has been produced as part of the Laboratory's strategic long-term research plan. It is published and made available by EPA's Office of Research and Development to assist the user community and to link researchers with their clients.

Lawrence W. Reiter, Acting Director.
National Risk Management Research Laboratory

Abstract

The National Risk Management Research Laboratory (NRMRL) developed a Risk Management Evaluation (RME) to provide information to help plan research dealing with the environmental impact of concentrated animal feeding operations (CAFOs). Methods of animal production in the U.S. have undergone fundamental changes in the last 30 years. The majority of meat, dairy, and poultry production has been concentrated into large facilities. Dairies with more than 2,000 cows and swine operations with more than 10,000 hogs are not unusual. Broiler houses with 50,000 birds are common. With the concentration of animals has come a concomitant concentration of manure production. One animal facility with a large population of animals can easily equal a small city in terms of waste production. Current practices of waste handling often include minimal or no treatment before the wastes are disseminated into the environment. The RME was developed to provide characterization of the waste problem, and a description of common environmental stressors and their movement including the air transport of pollutants. Current risk management practices in the animal industry are described, along with treatment approaches such as anaerobic/aerobic digestion, constructed wetlands, and disturbed land reclamation. Finally, suggested areas for future research are presented to help focus planning for the near future.

Table of Contents

1	OVERVIEW OF RISK MANAGEMENT DOCUMENT	1
2	INTRODUCTION	6
2.1	Agricultural Sectors Considered in this Document	6
3	MANURE PRODUCTION AND MANAGEMENT	7
3.1	Manure Quantities Among Animal Populations.....	7
3.1.1	Poultry.....	9
3.1.1.1	Broilers/Roasters and Turkeys.....	10
3.1.1.2	Layers.....	11
3.1.2	Swine.....	12
3.1.3	Cattle.....	15
3.1.3.1	Beef Feedlots	15
3.1.3.2	Dairy	17
3.2	Manure Characteristics.....	19
3.2.1	Physical Properties.....	20
3.2.2	Nutrient Content and Form from Poultry.....	21
3.2.2.1	Layers, Broilers, and Turkeys.....	21
3.2.2.2	Layers.....	21
3.2.2.3	Nutrient Content and Form from Swine	21
3.2.2.4	Nutrient Content and Form from Cattle.....	21
3.3	Manure Management Practices.....	22
3.3.1	Wet Manure Management.....	22
3.3.2	Dry Manure Management	22
4	WATERSHED STRESSORS IN CAFO WASTE	24
4.1	Nutrients.....	24
4.1.1	Nitrogen	25
4.1.2	Phosphorus.....	27
4.1.3	Mineral Salts	28
4.2	Pathogens	28
4.2.1	Pathogens of Concern at CAFOs	29
4.2.1.1	Bacteria	29
4.2.1.2	Fungi	30
4.2.1.3	Viruses	30
4.2.1.4	Helminths.....	30
4.2.1.5	Protozoa	30
4.2.2	Disease Descriptions.....	31
4.2.3	Effects of Pathogen Pollution	32
4.2.4	Human Diseases: Examples of Manure-Related Human Epidemics, Case Studies of Problems and Potential for Problems with Pathogens in Animal Manure.....	33
4.2.4.1	Walkerton, Ontario	33
4.2.4.2	Washington County Fair, New York	33
4.2.4.3	Carrolton, GA	34

4.2.4.4	Wilshire, Swindon, and Oxfordshire, England	34
4.2.4.5	Bradford, England.....	34
4.2.4.6	Milwaukee, Wisconsin.....	34
4.2.4.7	Maine	34
4.2.4.8	Sakai City, Japan.....	34
4.2.4.9	Cabool, Missouri.....	34
4.2.5	Animal Diseases.....	35
4.3	Antibiotics.....	36
4.3.1	Case studies on the effect of antibiotics related to CAFOs on the environment:	37
4.3.1.1	Case 1 – Chesapeake Bay	37
4.3.1.2	Case 2 – Iowa Swine Operations	37
4.3.1.3	Case 3 – Shoal Creek	38
4.3.1.4	Case 4 – A National Reconnaissance.....	38
4.4	Endocrine Disrupting Chemicals Associated with Concentrated Animal Feeding Operations....	38
4.4.1	Xenobiotic Hormones	40
4.4.2	Uses of Hormones in CAFOs	41
4.4.3	Release of Hormones to the Environment	42
4.5	Metals.....	43
4.5.1	Use of Metals in Animal Feed	43
4.5.2	Mobility of metals in soil.....	43
4.5.3	Metals in plants	45
4.5.4	Metals in Animals	46
4.5.5	Summary	46
5	STRESSOR TRANSPORT	48
5.1	Transport Mechanisms.....	48
5.1.1	Overland Transport in Wet Weather Flow.....	48
5.1.2	Physical and Chemical Processes Affecting Sediment Impacts	48
5.1.3	Overland Flow	48
5.1.4	Interflow.....	49
5.1.5	Groundwater flow	49
5.2	How These Processes Impact Typical CAFO Operations	49
5.2.1	Suspended Solids and Sediments (SSAS).....	50
5.2.2	Stress due to SSAS.....	51
5.3	Groundwater Transport.....	52
5.3.1	Statement of Problem.....	52
5.3.2	Pollutants, Sources, Transport, and Fate.....	53
5.3.2.1	Nitrogen	53
5.3.2.2	Ammonia.....	53
5.3.2.3	Nitrate	54
5.3.2.4	Phosphorus.....	55
5.3.2.5	Pathogens	56
5.3.3	Risk Management	57
5.3.4	Storage Facilities.....	57
5.3.5	Farming Practices.....	58
5.3.6	Natural Filters	61
6	AIR TRANSPORT AND DEPOSITION	63

6.1	Current Air Quality Issues Associated with Agriculture	63
6.1.1	Ammonia.....	63
6.1.2	Nitrous Oxide.....	64
6.1.3	Methane.....	64
6.1.4	Carbon dioxide.....	65
6.1.5	Hydrogen sulfide.....	65
6.1.6	Criteria Air Pollutants	65
6.2	Generation of Air Emissions Resulting from Operational Variables	66
6.2.1	Air Emissions from Land Application Activities	66
6.2.2	Odors.....	68
6.2.3	Particulate Matter.....	68
6.3	SUMMARY.....	69
7	RISK MANAGEMENT OPTIONS FOR CAFO WASTE	70
7.1	Land Application	70
7.2	Practices Used in Land Application.....	71
7.2.1	Application Systems	71
7.2.2	Potential Problems Associated with Manure Applications.....	72
7.2.3	Soil Management Practices to Reduce Problems.....	74
7.2.4	Runoff Control from Land Application Fields	74
7.2.4.1	Reducing Soil Detachment	74
7.2.4.2	Reducing SSAS Transport within a Field.....	75
7.2.4.3	Trapping Sediment after the Field	75
7.3	Composting of CAFO wastes	77
7.3.1	What is Composting?.....	77
7.3.2	Composting systems	78
7.3.2.1	Interventionary Systems.....	78
7.3.2.2	Non-Interventionary Systems	78
7.3.3	Comparison of Interventionary and Non-interventionary Systems	78
7.3.4	Composting in the Beef and Dairy Industries.....	78
7.3.4.1	Beef.....	78
7.3.4.2	Dairy	79
7.3.4.3	Composting Swine Waste	79
7.3.4.4	Composting Poultry Waste	80
7.3.5	Composting Concerns and Problems	81
7.3.5.1	Nutrients.....	81
7.3.5.2	Pathogens	81
7.3.6	Land Application of Compost.....	83
7.4	A Strategy Requiring Some Additional Research– Anaerobic Digestion	83
7.4.1	Technology Description.....	83
7.4.1.1	Covered Lagoons	83
7.4.1.2	Complete Mix Digester.....	84
7.4.1.3	Plug-flow Digester.....	85
7.4.2	Application.....	85
7.4.3	Operation and Performance	86
7.4.4	Fuel Gas Production.....	87

7.5	Technologies Requiring Significant Additional Research Before Implementation-Aerobic Digestion-Wetlands-Land Reclamation.....	88
7.5.1	Aerobic Digestion	88
7.5.1.1	Types of Aerobic Digestion Technologies	89
7.5.1.2	Application.....	89
7.5.2	Wetlands	90
7.5.2.1	Constructed Wetlands	90
7.5.2.2	Restored Wetlands	90
7.5.2.3	Enhancement Wetlands.....	90
7.5.2.4	Free Water Surface (FWS) Wetlands	90
7.5.2.5	Vegetated Submerged Bed (VSB) Wetlands	91
7.5.2.6	Reciprocating (ReCip) wetlands and vertical-flow (VF) wetlands.....	91
7.5.3	Treatment Mechanisms.....	91
7.5.4	Plant Functions.....	92
7.5.5	Risk Associated with Constructed Wetlands	93
7.5.6	Application and Performance of Constructed Wetlands for Agricultural Wastewaters	94
7.5.7	Processes to Significantly Reduce Pathogens (PSRP).....	97
7.5.8	Recommendation	97
7.5.8.1	Composting	97
7.5.8.2	Air Drying.....	98
7.5.8.3	Facultative lagoons / Storage.....	98
7.5.8.4	Anaerobic Digestion	98
7.5.8.5	Aerobic Digestion	99
7.5.8.6	Lime Stabilization.....	99
7.6	Land reclamation	100
7.6.1	Non-Farm Land Applications	100
7.6.2	Phytoremediation Projects, Sediment Recycling, and Landfill Covers	100
7.6.3	Riparian Corridors	100
7.6.4	Forest Products: Short Rotation Wood Crops- Pulp & Paper, Lumber, Fuel.....	100
7.6.5	Highways: Roadsides and Medians	101
8	RESEARCH NEEDS ASSOCIATED WITH CAFOS.....	102
8.1	Overview.....	102
8.2	Stressor Evaluation and Quantification	102
8.3	Process Research.....	103
8.4	Fate and Effects of Stressors in the Environment.....	103
8.5	Ground Water.....	104
8.6	Aerosol Research	105
8.7	Land Reclamation	106
9	REFERENCES	107

List of Tables

Table 3.1	Change in Animal Units, 1982 to 1997.	7
Table 3.2	Change in CAFO Operations from 1982 to 1997	8
Table 3.3	Manure Production per 1000 Pounds Live Weight on an Annual Basis	9
Table 3.4	Nitrogen and Phosphorus Content of Animal Waste	20
Table 3.5	Characteristics of Animal Manure Based on 1000 Pound Live Weight.....	20
Table 4.1	Diseases and Animals Commonly Identified as Sources of the Causative Organisms	30
Table 4.2	Examples of Manure-Related Human Epidemics.....	33
Table 4.3	Sources of Common Zoonotic Diseases on Farms	36
Table 4.4	Antibiotic Levels in the Lagoons and in One Monitoring Well (adapted from Table 7) (Iowa Dept. Public Health, 1997)	37
Table 4.5	Hormones Approved for Veterinary Use in Cattle	42
Table 4.6	Copper and Zinc in Swine Diets	43
Table 4.7	Soil Cu Balance after Five Years of Repeated Pig Slurry Application	44
Table 4.8	Soil Zn Balance after Five Years of Repeated Pig Slurry Application.....	44
Table 4.9	Cu and Zn in Soil (top 5 cm) February, 1987 and Herbage First Cut of 1986	45
Table 7.1	Functions of Soil Conservation Practices (adapted from USEPA, 2001a).....	76
Table 7.2	Status of Farm-Based Digesters in the United States	85
Table 7.3.	Performance Data Summarized for Gulf of Mexico Program (CH2M-Hill,1997).....	94
Table 7.4.	Agricultural Treatment Wetlands in the NADB	94
Table 7.5.	Range of Costs and Operating Parameters for NADB Agricultural Treatment Wetlands	95
Table 7.6.	95% Confidence Interval about the Mean for all NADB Agricultural Treatment Wetlands ..	95
Table 7.7.	Preliminary Averages for ReCip System Treating Swine Wastewater	97
Table 7.8.	Microbiological Quality Guidelines and Standards for Application of Wastes to Land	98
Table 7.9.	Effects of Waste Treatment and Management Systems on Pathogen Reduction	99

List of Figures

1.1	Phosphorus Assimilative Capacity for Farms	2
1.2	Excess Phosphorus on Farms with No Export	3
3.1	Poultry Production distribution in the United States.....	10
3.2	Turkey Production Distribution in the United States	11
3.3	Layer and Pullet Distribution in the United States.....	12
3.4	Change in Swine Production Distribution in the United States	13
3.5	Swine confinement barns with lagoon	14
3.6	Swine pens inside barn with slatted floors	14
3.7	Change in Cattle Locations as of the 1997 Census	15
3.8	Aerial view of a feedlot in Kansas with a lagoon	16
3.9	Change in Distribution of Dairy Cattle in the United States.....	17
3.10	Dairy farm with a manure storage tank.....	18
3.11	Dairy farm with poor manure management and detrimental impact on the environment	19
4.1	Depiction of Carbon and Nitrogen Cycles in Soils or Sediments	26
4.2	Diagrammatic Illustration of Preferential Flow through Macropores and Interstitial (porewater) Flow in the Soil Matrix	27
4.3	Frequency of Detection of Organic Wastewater Contaminants by General Use Category (4A), and Percent of Total Measured Concentration of Organic Wastewater Contaminants by General Use Category shown above Bar (Kolpin, et al., 2001).....	39
4.4	Structure of Biogenic Hormones.....	40
4.5	Chemical Structure of Trenbelone Acetate and Hydroxide	41
5.1	Transport Pathways of Pollutants Derived from Animal Waste	54
5.2	Nitrogen-Carbon Cycling in Soil/Sediment Derived from Animal Waste	55
5.3	Diagrammatic Illustration of Preferential Flow through Macropores and Interstitial (Pore-Water) Flow in the Soil Matrix	56
5.4	Concrete manure storage tank. Structures of this type will prevent leakage of wastes into groundwater. ...	59
5.5	A new lagoon with a synthetic geotextile liner to prevent seepage into groundwater.	60
5.6	Terraced fields to prevent erosion of soil on sloping land	61
6.1	High velocity sprinkler, a potential source of airborne contaminants.....	67
6.2	Tank truck applying manure with the potential for aerosol generation	67
7.1	Tractor drawn liquid manure application after corn harvest	72
7.2	Means of Manure Disposal by Animal Sector	72
7.3	Mixed compost from turkey waste.....	80
7.4	Turkey waste compost with wood chips and feathers.....	81
7.5	Truck mounted spreader applying compost to a field.....	84
7.6	Covered manure tank generating methane in Iowa.....	86
7.7	Free Water Surface (FWS) Wetlands.....	91
7.8	Vegetated Submerged Bed (VSB) Wetland	92
7.9	View of a hog operation with a lagoon flowing into constructed wetlands for treatment of wastewater	96
7.10	Ground level view of constructed wetland with the owner making observations for his records	96

Acknowledgements

The editors wish to thank S. Stoll for detailed assistance in editing this document for editorial quality.

In addition, several figures were derived from the USDA National Resources Conservation Service website and included in this document. The NRCS website is also a source for the pictures used in this document. The NRCS Photo Gallery contains natural resource and conservation related photos from across the USA. The Gallery is a joint project between NRCS Conservation Communications and the NRCS Information Technology Center in Ft. Collins, Colorado.

Photos in the Gallery are available free of charge in two common image formats: TIFF or JPEG. Image resolution is generally 1500 x 2100 pixels (5" x 7" at 300 dpi). TIFF images are 32 bit CMYK color, ranging from 6 mb to 12 mb in size. JPEG images are 24 bit RGB color ranging from 200 kb to 400 kb in size.

If you use any of these photos in a publication, on a web site, or as part of any other project, please use one of the following credit lines:

- Photo by (photographer's name), USDA Natural Resources Conservation Service.
- Photo courtesy of USDA Natural Resources Conservation Service.
- Photo courtesy of USDA NRCS.

These photos may not be used to infer or imply NRCS endorsement of any product, company, or position. Please do not distort or alter the images the photos portray.

Other figures were derived from the USDA National Agricultural Statistics Service website and included in this document.

The list of figures derived from the NRCS and NASS is as follows:

Cover photographs.....	NRCS
Figure 1.1	NRCS
Figure 1.2	NRCS
Figure 3.1	NRCS
Figure 3.2	NASS
Figure 3.3	NASS
Figure 3.4	NRCS
Figure 3.7	NRCS
Figure 3.9	NRCS

Photographs as Figures

Figure 3.5	NRCS
Figure 3.6	NRCS
Figure 3.8	NRCS
Figure 3.10	NRCS
Figure 3.11	NRCS

Figure 5.4	NRCS
Figure 5.5	NRCS
Figure 5.6	NRCS
Figure 6.1	NRCS
Figure 6.2	NRCS
Figure 7.1	NRCS
Figure 7.3	NRCS
Figure 7.4	NRCS
Figure 7.5	NRCS
Figure 7.6	NRCS
Figure 7.9	NRCS
Figure 7.10	NRCS

Contributors

Edwin Barth	Aerosols
Dr. Donald Brown	Wetlands
Dr. John Cicmanec	Pathogenic Organisms and Background
Jennifer Goetz	Antibiotics
Dr. John Haines	Land Application
Dr. Mohamed Hantush	Groundwater
Ronald Herrmann	Composting
Dr. Paul McCauley	Nutrients
Kim McClellan	Aerosols
Dr. Marc Mills	Sediments and Wet Weather Flow
Teri Richardson	Digestion
Steven Rock	Land Reclamation
Sally Stoll	Metals
Dr. Gregory Sayles	Endocrine Disrupting Compounds
Dr. James Smith	Pathogenic Organisms
Stephen Wright	Sediments and Wet Weather Flow

Editors: Dr. John Haines and Laurel Staley

1 OVERVIEW OF RISK MANAGEMENT DOCUMENT

This document is intended to help the reader gain an understanding of potential environmental problems associated with Concentrated Animal Feeding Operations (CAFOs). Although a variety of animals are raised in CAFOs, this document will focus on beef, dairy, swine and poultry. The quantities and characteristics of manure produced by the different animals are presented. The watershed stressors resulting from CAFO pollution are discussed, as are the transport mechanisms that disperse them through the environment. Common manure management practices are also presented.

Because large numbers of animals are confined in relatively small areas at CAFOs, a very large volume of manure is produced and must be kept in a correspondingly small area until disposed of. The age-old practice of land application is used, but the volumes of manure that must be disposed in this way frequently exceed the assimilative capacity of land within economic transport distances. This may result in the release of excess manure to watershed environments during the catastrophic breach of holding facilities or more commonly, during the intermittent runoff of excess manure applied to already saturated land. Figure 1.1 shows the phosphorus assimilative capacity of farmland in the United States. Figure 1.2 shows the excess phosphorus available on farms with no export. Clearly, an imbalance exists between available phosphorus and the capacity of the land to absorb phosphorus. The same general relationship holds for nitrogen. If land in entire counties were available for application of animal waste, the overburden of nutrients is somewhat relieved, but excess quantities of nutrients still exist in some locales. Neither of the maps shown takes into account fertilizer applied to fields.

This would be a problem even if manure contained only beneficial nutrients. In excess amounts, these nutrients damage, not improve, soil fertility and may pollute nearby water. More importantly, however, manure from CAFOs contains components other than nutrients. The dominant element in manure is carbon. Many of the carbon compounds in manure may contribute to oxygen depletion in water. The nutrient elements N and P in manures may also contribute to eutrophication of water if their entry into water is not controlled. Modern agriculture with its emphasis on intensive housing and speeding the growth of livestock to market weight has employed a variety of substances that have not been used before in animal husbandry. These include antibiotics to combat the spread of disease among animals housed in close quarters, natural and synthetic hormones to speed growth, and metals (As, Cu, Zn) to do the same and preserve the freshness of feed. When present in the large amounts of manure generated at CAFOs and stored on-site, these other substances pose a threat to the environment. The effects of antibiotics on native soil bacteria are largely unknown. The effects of biogenic and synthetic hormones on other animals and humans are largely unknown.

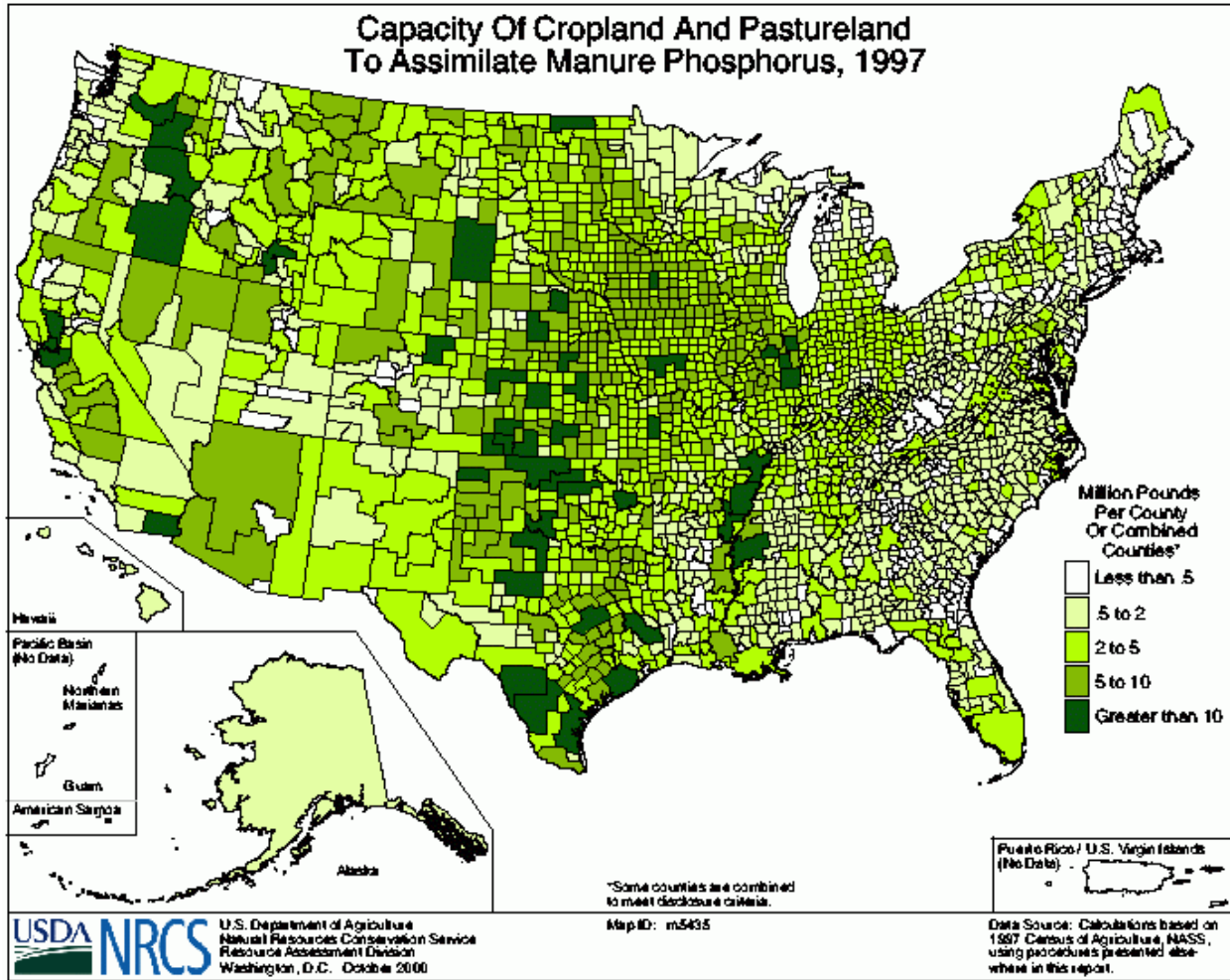

Figure 1.1. Phosphorus assimilative capacity for farms.

This Risk Management Evaluation (RME) is intended to document the salient environmental risks associated with hog, poultry, dairy and beef CAFOs and actions that could be taken to reduce those risks now. Areas in which further research is needed are identified and discussed in Section 8 of this document.

In reviewing the existing body of knowledge on intensive livestock agriculture, the following points became clear.

- Underlying all of the environmental problems associated with CAFOs is the fact that too much manure accumulates in restricted areas. Traditional means of using manure are not adequate to contend with the large volumes present at CAFOs.
- The nutrient load from CAFOs is large, with about 2.5 billion pounds of N and 1.4 billion pounds of P recoverable in manure. Total manure N is about 12.9 billion pounds and total manure P is about 3.8 billion pounds.

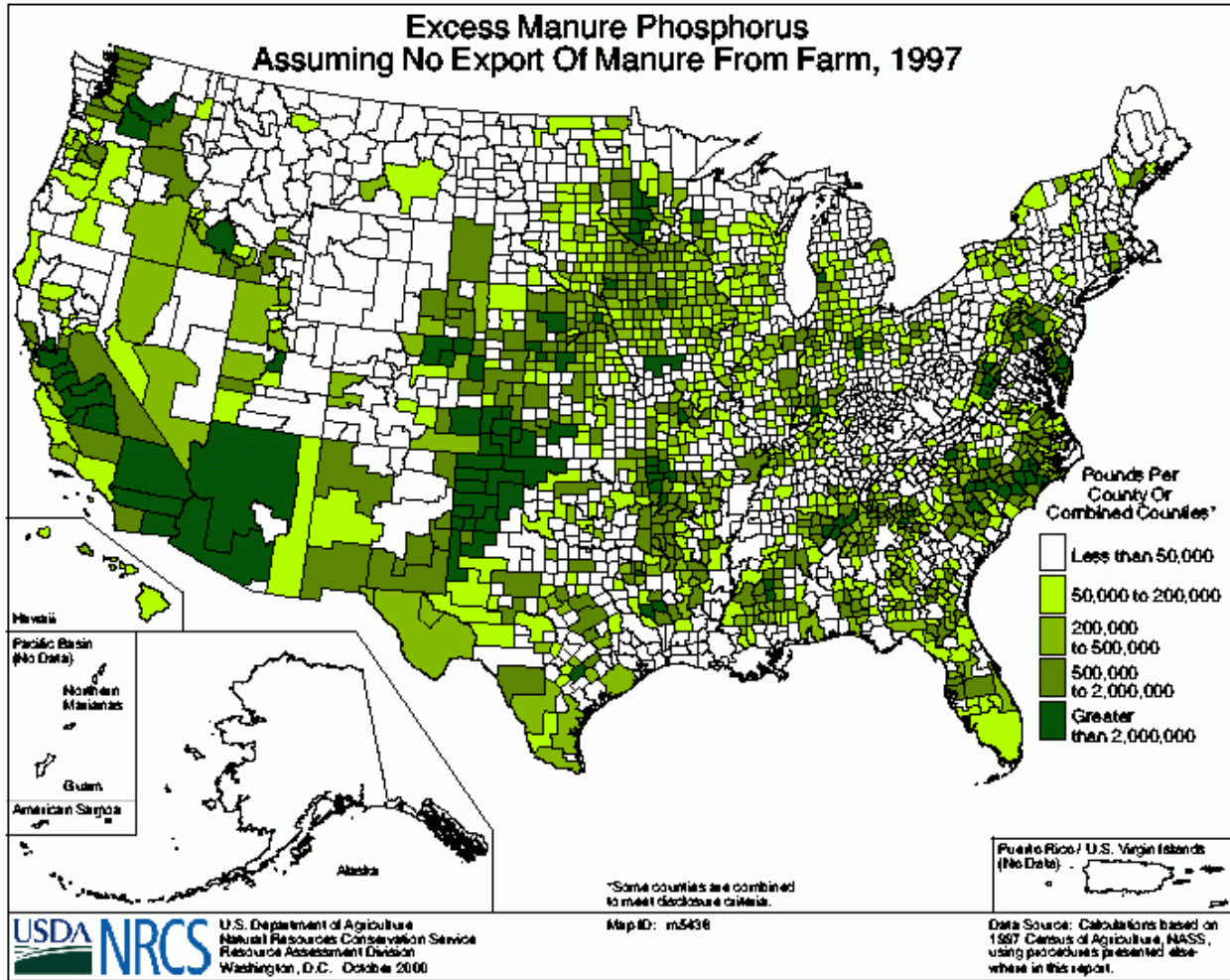

Figure 1.2. Excess phosphorus on farms with no export.

- CAFO manure contains potentially pathogenic microorganisms. The combination of large herds and closely confined housing makes it likely that at least some animals are asymptomatic carriers of pathogenic organisms. Once introduced, these pathogens may readily spread among the closely confined herd. Shed into the manure, these pathogens find favorable breeding grounds in the barns, manure storage and handling systems and are released into the watershed environment routinely during the land application of waste.
- The antibiotics administered to CAFO livestock may contribute to the development of antibiotic resistant strains of pathogens – especially those harbored within the livestock raised at these facilities. The sub-therapeutic use of antibiotics at CAFOs aggravates the problem.
- Naturally occurring and synthetic hormones administered to livestock to speed growth to market weight pollute the environment when released along with manure during land application or during an accidental release. The environmental effects of these compounds are largely unknown.

- Metals used as feed supplements to promote livestock growth may degrade the quality of the land to which waste is applied. Adverse environmental effects may result when waste containing metals is released into the watershed.
- Transport pathways for stressors from CAFOs encompass surface runoff, air transport and redeposition, and groundwater flow. Nutrients, pathogenic organisms, hormones and metals may easily reach waterbodies via these means.

There are measures that may be taken now to mitigate the risk posed by the large volumes of manure at CAFOs.

- Reduce the volumes of manure created by changing waste management, handling practices, and feed utilization efficiency.
- Treat manure to kill pathogens, attenuate hormones and other organic contaminants, and stabilize metals.
- Increase use of anaerobic treatment and composting to control odors, nutrients, pathogens, and generate renewable energy.
- Reduce the use of antibiotics to stem the development of antibiotic resistant pathogens.
- Increase soil conservation methods to reduce runoff and erosion from fields to which manure has been applied. Reduced tillage, terraces, grassed waterways, and contour planting offer conservation benefits.
- Install barriers such as riparian zones and wetlands to prevent manure-laden runoff from fields from reaching streams.
- Change barn ventilation and manure management and handling practices to minimize the airborne release of stressors.
- Where economic factors work against making changes to CAFO management practices, eliminate them or provide incentives for making such changes.

Additional research needs to be undertaken to develop a range of alternatives for managing CAFO manure. The U.S. Department of Agriculture is engaged in research to address many of these questions, especially with respect to nutrient issues. EPA intends to complement their efforts by working with them on mitigation strategies for nutrients and, more importantly, focusing on pathogen, hormone and metal issues.

The environmental challenges posed by CAFOs are not insoluble. In some cases, simple management of wastes in different ways will ameliorate some of the problems. More attention to good soil management and application of wastes at phosphorus based agronomic rates will reduce loads of pollutants reaching water bodies. Development of means to extract value from wastes will be needed to make treatment feasible and reduce health risks. Nitrogen, phosphorus and methane are some of the potentially valuable products recoverable from manures. The key problem for managing CAFO waste is one of distribution of the manure from points of production to application sites in an economically viable manner.

Beyond manure management, new issues are emerging such as the environmental impact of aquaculture and other intensive agricultural operations, the environmental effects of different types of mortality management, and how to mitigate the hydrologic changes brought about by large CAFO operations. These issues will be addressed in future versions of this RME.

2 INTRODUCTION

2.1 Agricultural Sectors Considered in this Document

Hog, poultry beef, and dairy production are considered in this document. Although there are other livestock production sectors that utilize intensive production methods, these represent the sectors most often identified as the cause of water quality problems caused by animal agriculture (USEPA, 2001). The recently promulgated rule addresses only these four agricultural sectors.

Animal production agriculture in recent years has evolved into a system with highly integrated production. A company known as an integrator owns all of the components of production from the feed, the animals themselves, and the slaughterhouse. Large numbers of animals are kept in barns or in the case of beef cattle in feedlots that are owned by a farmer who is acting as an independent contractor for the integrator. The farmer owns the facility where the animals are housed and fed. Typically, the farmer is responsible for manure handling, safe storage, and disposal. This usually means that the manure is stored in large piles or impoundments until it may be applied to the land. Manure has long been applied to agricultural land as a fertilizer and as a means of soil improvement. Today, however, the large numbers of animals housed in CAFOs generate waste on a scale that may overwhelm the capacity of the adjacent land to absorb it. It is this excess manure that causes the environmental problems associated with CAFOs.

Manure production varies by animal species, diet, and age of the animal. An animal unit is a 1000-pound animal, frequently taken as one market-weight beef animal. Each animal generates approximately 50 to 60 pounds of manure per day. From these figures, it may be seen that the waste load for a 1000 animal unit facility is quite large. For example, a beef feedlot with 1000 animals produces about 21,000,000 lbs of manure per year.

3 MANURE PRODUCTION AND MANAGEMENT

3.1 Manure Quantities Among Animal Populations

Animal farms produce as much manure as small and medium-size cities. A farm with 2500 dairy cattle is similar in waste load to a city of 411,000 people. Since about 1970, production of hogs, beef, poultry, and dairy has become concentrated into fewer large units. Between 1982 and 1997, the most recent years for which animal census data are available, the number of livestock has remained relatively constant, but the number of farms has declined significantly. Dramatic changes have occurred in American agriculture between 1982 and 1997, the most recent years for which animal census figures are available. The most significant change is the shift from small farms to the much larger, concentrated animal feeding operations (CAFOs). Table 3.1 shows a summary of changes in confined animal units from 1982 to 1997.

Table 3.1 Change in confined animal units, 1982 to 1997

Animal type	Size class	1982	1997	Percent change
Milk Cows	300-999	1,281,300	1,835,832	+43
	>1000	578,223	2,135,205	+265
	All smaller size classes decreased			
Beef	150-299	647,880	721,624	+11
	300-999	615,890	836,548	+36
	>1000	325,150	508,268	+56
All smaller classes decreased				
Swine	150-299	948,702	1,196,911	+26
	300-999	654,301	2,113,110	+223
	>1000	213,048	2,851,534	+1238
All smaller classes decreased				
Poultry	150-299	651,816	1,264,537	+94
	300-999	881,644	1,650,785	+87
	>1000	835,889	1,832,509	+119
All smaller classes decreased				

The definition of a CAFO listed in the regulation development document (USEPA, 2001) is used in this document. A CAFO is an animal feeding facility that has more than 1000 animal units, or has between 300 and 1000 animal units and meets certain conditions or is designated a CAFO by the state, or has less than 300 animal units and is designated a CAFO by the state. The smaller size facilities are designated CAFOs primarily due to the potential the facility has for discharging pollutants to the waters of the United States. Animals must also be present in the facility for at least 45 days. The CAFO neither stores nor grows crops. Waste containment and disposal are also part of the CAFO designation. Poultry facilities are CAFOs if they contain more than 55,000 turkeys; 100,000 or more broilers or hens with continuous overflow watering; 30,000 or more hens or broilers with a liquid manure system; or 5,000 or more ducks. Designation as a CAFO requires the facility to obtain a NPDES discharge permit.

In 1982, CAFOs comprised only 3% of all farm operations and more importantly, only 35% of the total animal population. In 1997, CAFOs had risen to 5% of all farm operations and 50% of the animal population. The circumstances associated with these changes in animal population are unique for each of

the four principal farm animal group categories; beef cattle, dairy cattle, hogs, and poultry. Table 3.2 shows the changes in CAFO operations from 1982 to 1997, based on animal unit size classes.

These changes have been principally driven by economic factors, mostly economy of scale, that is, a few large farm units have the potential to be much more cost and operationally efficient than many small farm units. Perhaps the significance of the reduction in small farm units maybe made most dramatically by comparing the numbers of farm units in 1982 to 1997. In 1982, there were 1,260,085 farms with fewer than 150 animals compared to 921,957 in 1997. This represents a 26% reduction in the total number of small farm units. Meanwhile, the number of large farms with more than 1000 head of livestock increased from 5442 farms in 1982 to 8021 farms in 1997, which represents a 47% increase. And of course, the actual “shift” in numbers of animal units is even more dramatic. There were 45.8 million animals on small farms in 1982, but by 1997 this number was reduced to 34 million animals. Interestingly, this is a 26% reduction in the total animal population for small farms. In contrast, large farm operations, that is, those with more than 1000 animals, increased from 15.7 million in 1982 to 24.9 million in 1997, a 58% increase.

Table 3.2 Change in CAFO operations from 1982 to 1997

Animal type	Size class ¹	1982	1997	Percent change
Milk cows	300-999	3,385	4,534	+34
	>1,000	456	1,303	+186
Other beef and dairy	150-299	34,370	36,421	+6
	300-999	16,827	19,541	+16
	>1,000	2524	3,008	+19
Swine	150-299	4,730	5,726	+21
	300-999	1,432	4,134	+189
	>1,000	103	1,011	+882
Poultry	150-299	3,175	6,129	+93
	300-999	1,786	3,312	+85
	>1,000	362	688	+90

¹All smaller size classes decreased in number

Different parts of the United States are associated with major production facilities. See Figures 3.1 through 3.4 for locations of major animal production locales. The different animal production sectors are vertically integrated to various degrees. Poultry production is most highly integrated, followed by pork, dairy, and beef. The manure production by all of these animals is immense. Manure production varies by the animal species, diet of the animal, and age of the animal. Table 3.3 presents some data comparing manure production by the major animal groups.

Table 3.3 Manure production per 1000 pounds live weight, on an annual basis.

Animal Species	Manure produced lbs./yr	Typical Handling System	Tons per Year for 1000 Animal Unit CAFO
Swine	29,000	Liquid	14,500
Poultry			
Broilers	28,000	Solid	14,000
Layers	22,000	Liquid	11,000
Turkeys	16,000	Solid	8,000
Beef	21,000	Solid	10,500
Dairy	30,000	Liquid	15,000
Humans	1,223 ¹	Liquid	611

¹Based on 150 lb avg. wt. per person producing 0.5 lb of fecal material per day

On a 1000 pound live weight basis, each of these animals produces more waste than a human. A CAFO with 1000 animal units of turkeys produces a waste load comparable to a city of 87,700 people. A dairy CAFO with 1000 animal units is equivalent to a city of 164,500 people. The important difference lies in the fact that human waste is treated before discharge into the environment, but animal waste is either not treated at all or minimally treated by virtue of the storage methods used before disposal.

3.1.1 Poultry

Poultry production (broilers, roasters, turkeys and eggs) is heavily concentrated in relatively few states. Chicken production occurs in Georgia, Arkansas, Alabama, Michigan, North Carolina, Missouri, Texas, and Delaware. Egg production occurs in Ohio, California, Pennsylvania, Indiana, Iowa, Georgia, Texas, Arkansas, and North Carolina. Turkey production occurs in North Carolina, Minnesota, Virginia, Arkansas, California, Missouri, and Texas. These states are those with the largest facilities. Other states may have CAFO sized production units, but not be among the largest. Poultry are not usually calculated as animal units due to the composition of their manure. Broiler manure has a N:P ratio of 3.6:1 and layer manure has a N:P ratio of 2.7:1. The N:P ratio of turkey manure is about 2.7:1. Poultry manure is quite high in phosphorus compared with other animal species. In some cases N and P are almost equal in concentration.

The total quantity of 120 million wet tons of poultry manure was estimated for 2001, and this figure represents an increase of more than 80 % compared to 1982. Clearly, this quantitative increase is the greatest change for all categories of animal fecal production. Some of the largest poultry operations are now located in North Carolina, Arkansas, and the Delmarva peninsula. Today, most poultry production comes from large concentrated egg or broiler operations. Delaware, as one example, may produce up to 250,000,000 chickens or more in one year. The waste generated contains more nitrogen and phosphorus than may possibly be used as fertilizer in Delaware for crop production.

Manure production and manure handling is similar in broilers and turkeys, resulting in similar nutrient concentrations. The floor is covered with moisture absorbing bedding and is ventilated. This airflow removes ammonia and other gases leaving a nitrogen-depleted manure. Broiler manure as excreted has a nitrogen content of 401 lb/yr/1,000 lbs of animal weight (USDA, 1998); broiler house litter has a nitrogen content of 27 lb/yr/1,000 lbs of animal weight (USDA, 1992). Some of this decrease in nitrogen may be explained by solubilization as when bedding is washed off the floor rather than scraped, as shown by the decrease in phosphorus and potassium from 117 and 157, respectively, to 113 and 111 lb/yr/1,000 lbs of animal weight. The much larger percent loss of nitrogen results from off-gassing of ammonia.

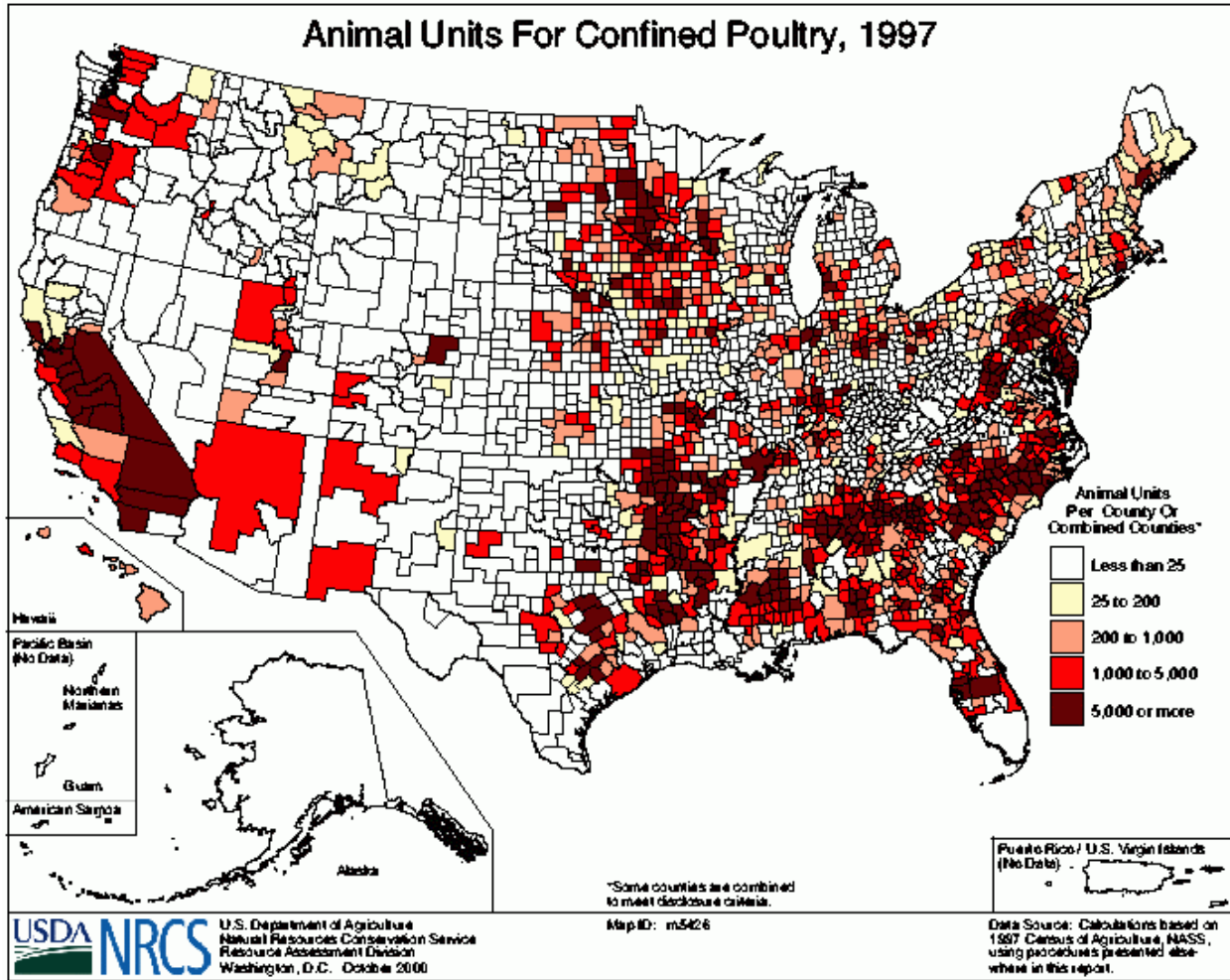

Figure 3.1. Poultry production distribution in the United States.

3.1.1.1 Broilers/Roasters and Turkeys

Broiler production in the United States was about 8.4 billion in 2001. The average cycle time for broilers is about 47 days. The total amount of waste generated by broilers is estimated at 79 million wet tons per year taking into account the cycle time of production. This estimate may be a high estimate because it does not take into account the fraction of birds sold at much lower weights for different markets. Turkey production also has multiple cycles per year. A good estimate is three production cycles of about 17 weeks each. The amount of waste generated is estimated at 21 million tons per year with three production cycles. Most waste is handled as dry rather than liquid systems.

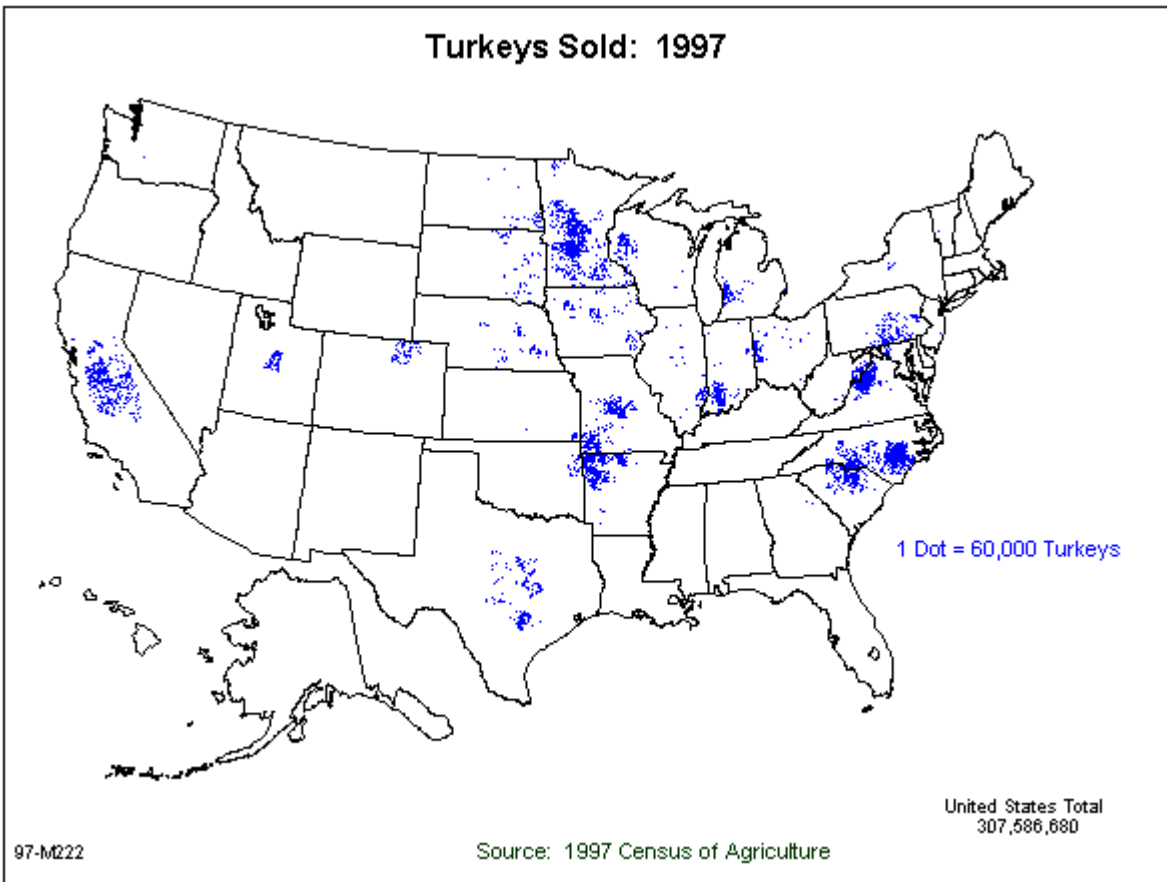

Figure 3.2. Turkey production distribution in the United States.

3.1.1.2 Layers

The estimated number of layers in the United States is about 367,000,000. The life cycle of layers is usually more than a year. The manure production by layers is estimated to be about 19 million tons per year. It is possible to have layer flocks more than one year in age before market. The apparent maximum for layers is about two years. Layer manure production often includes no bedding, it is handled as raw dried manure or water flushed manure. Water flushing manure results in dilution with concurrent increase in volume. Raw manure contains 308, 114, and 120 lb/yr/1,000 lbs of animal weight of nitrogen, phosphorus and potassium (USDA, 1998). Dry manure may lose up to 50% of the nitrogen content as volatile ammonia. Poultry manure dries rapidly and may be scraped off of flooring and stored dry in stacks or cakes. Dilution in lagoons and slurries may result in concentration reduction to as little as 10% of the raw manure value (USDA, 1992).

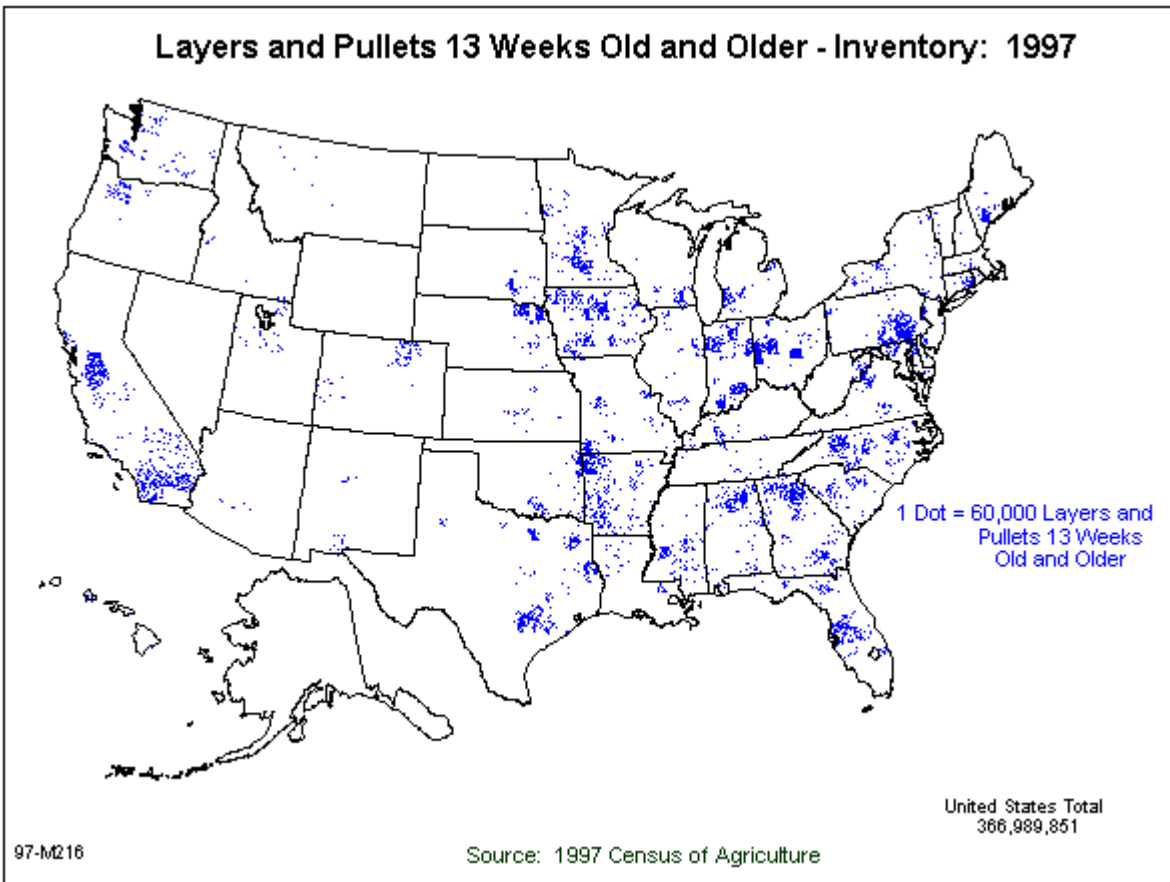

Figure 3.3. Layer and pullet distribution in the United States.

3.1.2 Swine

Hogs may live in several types of CAFOs throughout their life. Breeder facilities produce feeder pigs from birth to about 15 pounds, nursery facilities raise the pigs to 40 to 60 pounds, and grower/finisher facilities raise the pigs from 60 pounds to market weight of about 250 pounds. The total quantity of manure produced by both breeding hogs and hogs for slaughter was 177 million tons (from 8.5 million swine) and essentially this quantity was excreted in confined animal feeding operations. A variety of wet-handling and dry-handling systems were used. There has been a dramatic shift in the location of confined hog farm operations with North Carolina now being the most popular state with Iowa and Nebraska following behind. Figure 3.4 shows the change in confined animal units from 1982 to 1997. There has been a large shift to confined operations.

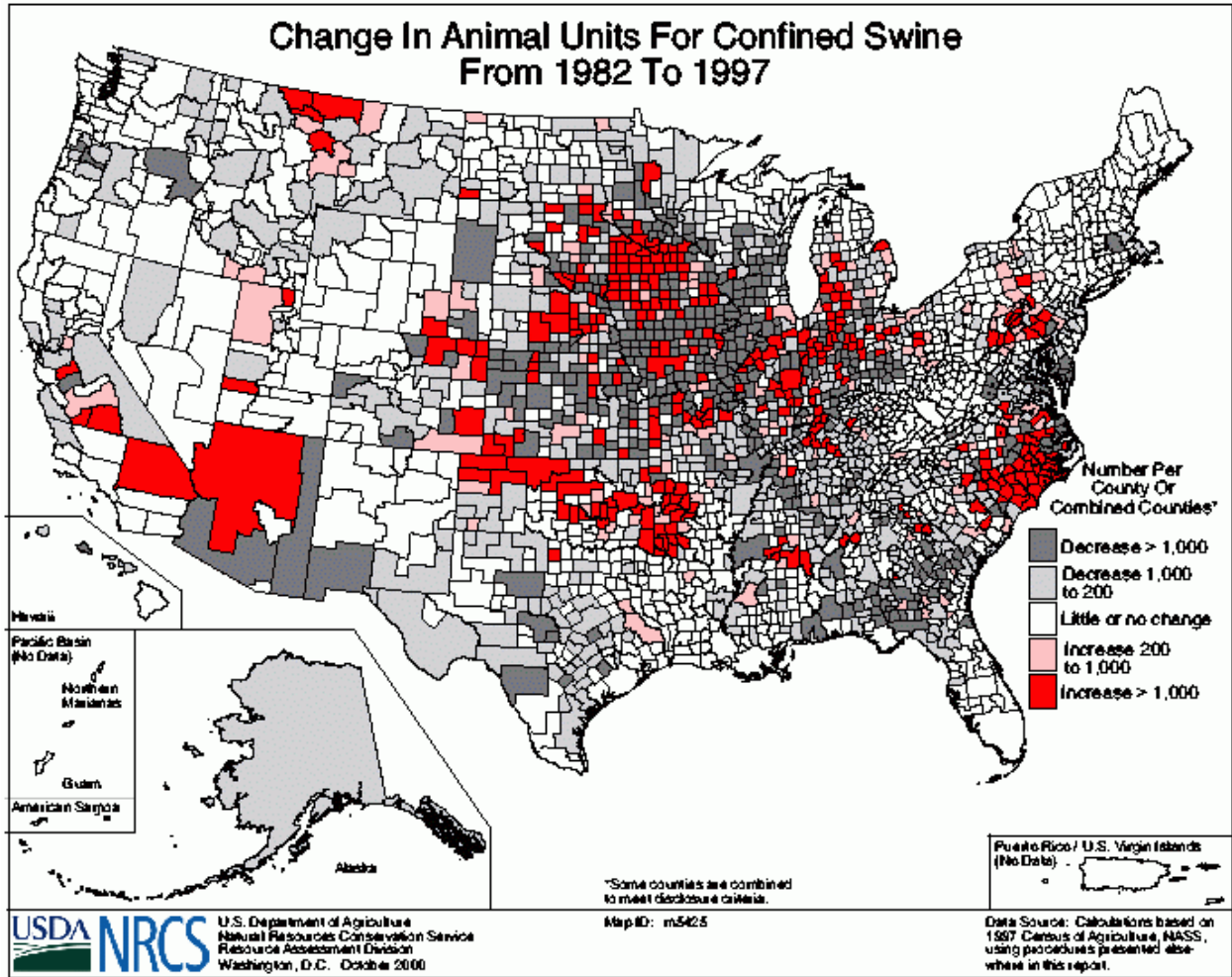

Figure 3.4. Change in swine production distribution in the United States.

Figure 3.5 shows a modern hog confinement facility with a waste lagoon. The hogs may be confined in pens as shown in Figure 3.6. In this type of facility the manure drops through the slatted floors into channels that are periodically flushed with supernatant water from the lagoon. The floors are either scraped or washed with water to move the waste into the subfloor channels. Demonstration projects have been completed wherein the lagoon is covered with a synthetic material, and the lagoon is converted to an anaerobic digester. Some farms have found it practical to recover methane from the lagoon to supply electricity and heat for the farm.



Photo courtesy of USDA NRCS.

Figure 3.5. Swine confinement barns with lagoon.



Photo courtesy of USDA NRCS.

Figure 3.6. Swine pens inside barn with slatted floors.

3.1.3 Cattle

3.1.3.1 Beef Feedlots

Beef cattle generate about 21,000 lbs of manure per animal per year, assuming one animal is one animal unit. Beef production starts with cow/calf operations that produce feeder calves for feeding operations. Calves are fed from birth to about 400 pounds. Then they are transferred to feeding operations that feed them to market weight of about 1200 pounds. Veal calves are usually male calves fed in confinement to about 450 pounds. The beef industry is located primarily in the central United States. The largest operations are in the Great Plains states, Texas, Kansas, Nebraska, and Colorado.

There has been a large shift in cattle production to the central United States as shown in Figure 3.7. Many areas have lost cattle production while Nebraska, Kansas, Oklahoma, and Texas have had great increases in cattle production.

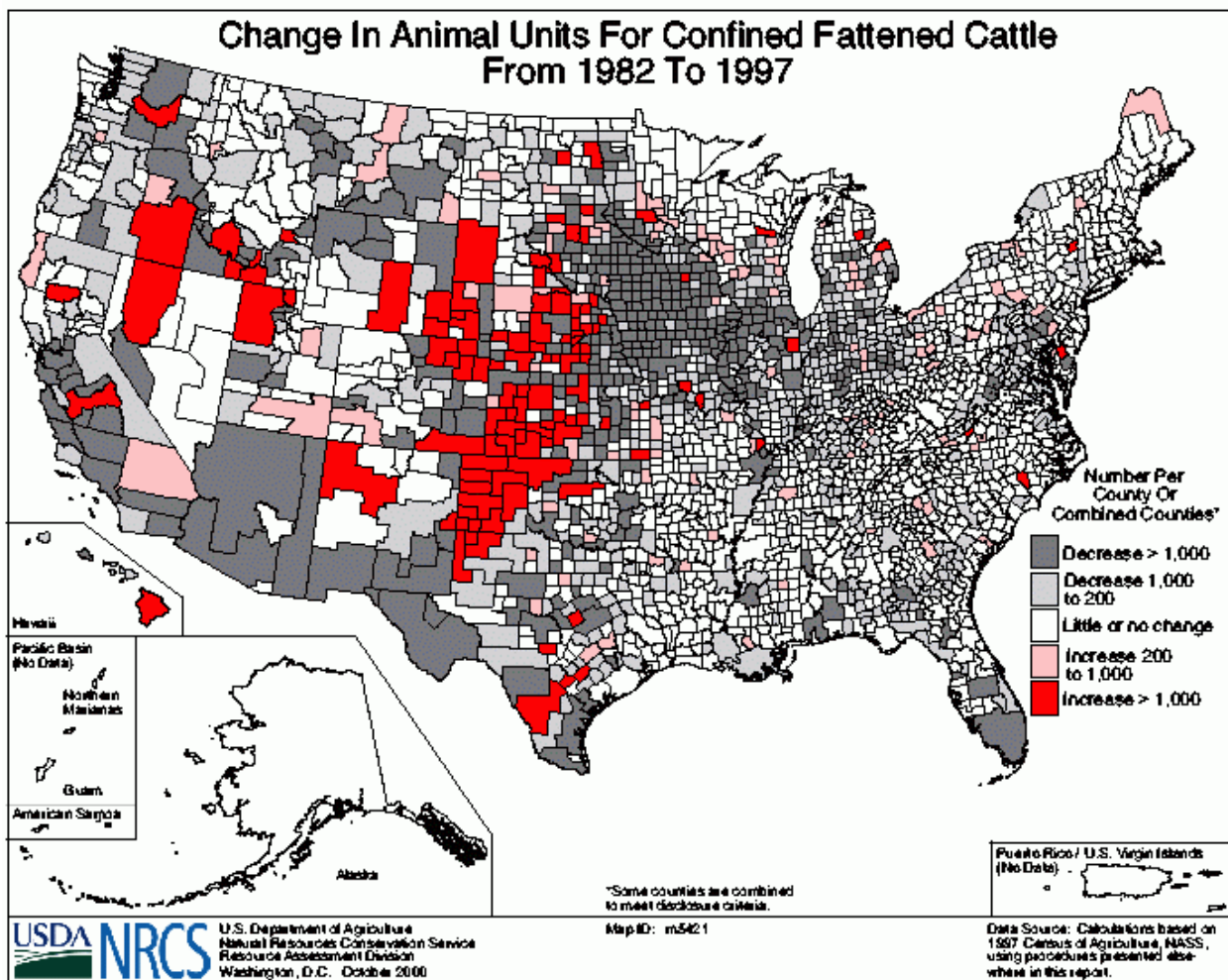

Figure 3.7. Change in cattle locations as of 1997 Census.

Figure 3.8 shows an aerial view of a large feedlot in Kansas. A waste lagoon is in the lower center of the picture. There is an area above the lagoon that appears to be the inflow area for the lagoon, but may also drain to unprotected streams. In large feedlots as shown in the figure, waste is generally scraped from the surface of the lot and piled nearby until it may be moved from the site for field application. A limited amount of treatment occurs in the piles due to self-heating of the material. Treatment by composting could be implemented relatively easily with the manure scraped from feedlots. The compost could then be sold as a value added product. The cost would be in the additional handling required to manage the composting process. Veal calf production is more likely to use a fully liquid manure system to handle wastes because the animals produce waste with higher water content and are held in confinement where water cleaning of the barns is practiced.



Photo courtesy of USDA NRCS.

Figure 3.8. Aerial view of a feedlot in Kansas with a lagoon.

Perhaps one of the most important facts for the purposes of this document is that a total of 806 million wet tons of manure were shed by beef cattle in 1997 (only 13% of this quantity was excreted within CAFOs, however). The quantity of manure produced by fattening beef cattle in CAFOs increased only 3% in the fifteen-year interval from 1982 to 1997. Beef feedlot wastes vary widely due to climate, diet, feedlot surface, animal density, and frequency of cleaning. Aged manure loses, on a dry weight basis, up to 60% of the nitrogen, 50% of the phosphorus, and 35% of the potassium (Mathers, 1972) to volatilization, runoff, or leaching.

3.1.3.2 Dairy

Dairy production is more evenly distributed due partially to the highly perishable nature of milk. Large dairy operations exist in California, New York, Wisconsin, Pennsylvania, Minnesota, Texas, Michigan, Washington, Idaho, Ohio, New Mexico, and Arizona, Texas, Idaho, New Mexico, and Arizona.

The distribution of dairy operations in the United States is shown in Figure 3.9. The highly perishable nature of milk suggests a reason for the more even distribution of dairies than beef feedlots.

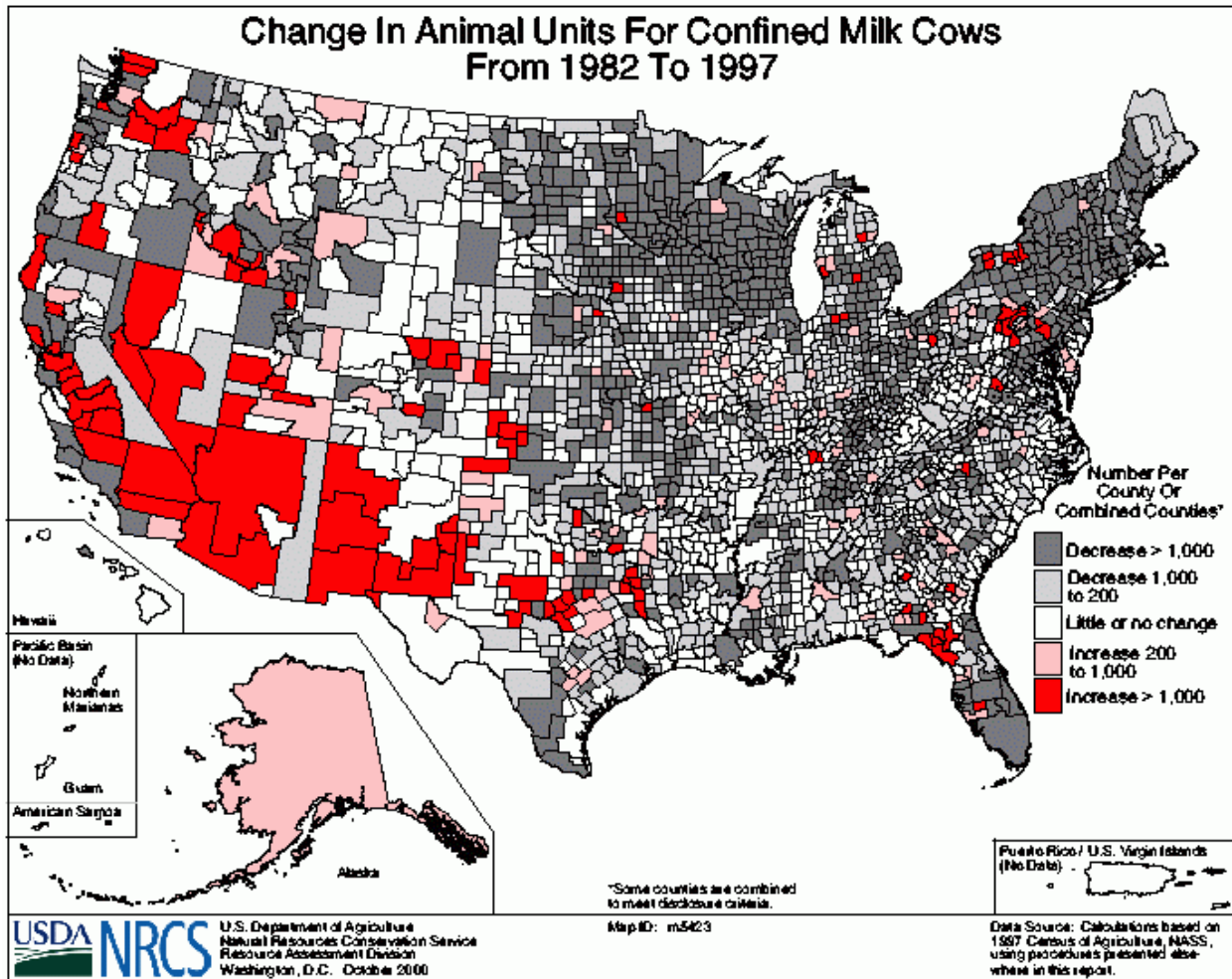

Figure 3.9. Change in distribution of dairy cattle in the United States.

Some dairies practice good control of waste both for nutrient management and for good environmental practice. Figure 3.10 shows a manure storage tank that gives the farmer good control over waste management. Tanks as shown may not be feasible for large dairies with large animal populations due to the volume of manure produced. Figure 3.11 shows a dairy farm with poor control of waste with consequent poor nutrient and environmental practices. This farm is losing valuable nutrients to runoff and possibly contaminating local streams with manure. Dairies may practice a variety of waste handling methods. Large dairies with large lot areas may handle wastes by scraping the lots and piling the waste until



Photo courtesy of USDA NRCS.

Figure 3.10. Dairy farm with manure storage tank

it may be field applied or further processed by composting. Milk house waste is frequently combined with the wash water and transferred to lagoons as a disposal mechanism separately from the feedlot waste. In this case there are two waste systems. Dairies with cows housed in barns and little or no outside activity usually have a combined waste system wherein the milk house waste, wash water and barn waste are combined in a mostly liquid system.

Dairy cattle produced 187 million wet tons of manure in 1997, representing an increase of 25% from the amount produced in 1982. Essentially this entire amount of fecal matter originated within CAFOs. Dairy manure as excreted contains on average TKN 164, phosphorus 29, and potassium 102 pounds/year/1000 pounds of animal mass (Lander, 1998). Water washed systems with lagoon storage may generate losses of 30-75% of the nitrogen (USDA 1992). The fecal matter produced within these operations was handled and disposed of under a variety of wet and dry handling systems and in some instances enclosed anaerobic digester systems have been employed so that methane gas production was optimized and then captured for conversion into electrical energy.



Photo courtesy of USDA NRCS.

Figure 3.11. Dairy farm with poor manure management and detrimental impact on the environment.

3.2 Manure Characteristics.

After the animals have defecated, the manure begins changing characteristics. Manure is a dynamic material, because it contains organic matter, nutrients, water, and microorganisms. Manure begins to lose N as NH_3 almost immediately. Between defecation and application of manure to soil, volatile N losses may be up to 90%. The N loss adversely affects the fertilizer value of the manure by reducing the N:P ratio. In most cases, conservation of the N is beneficial economically. Loss of N as NH_3 also raises an air pollution concern, as the N may be redeposited in watersheds where it becomes a pollutant. Esthetically, loss of N as NH_3 may create odor problems, leading to public disapproval of manure application, even though it is agronomically beneficial. Ammonia losses are minimized by direct injection or incorporation of manure into the soil surface. Up to 98% of N may be retained by injection. Maximum loss of N occurs when manure is applied by high velocity sprinkler systems. The sprayers maximize air exposure of the waste and consequently NH_3 loss. Phosphorus is not generally susceptible to volatility losses.

The nutrient value of animal waste varies according to animal species and waste handling systems. The nitrogen and phosphorus content of waste change greatly between excretion and field application. The urea and ammonia content of waste is especially susceptible to loss to atmosphere. This represents a potential economic loss as well as a transfer of a pollutant from one medium to another. Lagoon-based systems tend to accumulate phosphorus in the sludge layer on the bottom. Periodic removal of the supernatant disperses the N and P in the liquid phase. Eventually, the sludge layer will have to be removed to regain storage capacity. Due to the increased P content relative to the supernatant, the land area required

for disposal will be greatly increased to prevent overloading with P. Examples of waste nutrient content are shown in Table 3.4.

Table 3.4. Nitrogen and Phosphorus Content of Animal Waste

Species	As excreted, lb/1000 lb/year		As applied, lb/1000 lb/year	
	N	P	N	P
Swine	54-228	18-168	17-20	17-22
Poultry, broiler	310-401	71-124	109	112, stockpile
Poultry, layer	264-315	99-113	238	94,pit
Turkey	204-270	84-120	102-132	82-102
Dairy	150-164	29-60	117	35
Beef	99-124	24-116	77	23-51

The wide range of nutrient content observed reinforces the need for the individual CAFO operator to have periodic manure analyses done. An annual analysis will provide adequate information for planning application for crops.

3.2.1 Physical Properties

The physical properties of manure produced by the main commercial animal species have some common and some individual characteristics. Poultry manure is drier upon excretion than manure produced by any other common species. The characteristics of manure of most interest for the purposes of this document include the moisture content, nutrient content, COD, and BOD representative of the different animal manures. Table 3.5 summarizes basic data on manure characteristics.

Table 3.5. Characteristics of animal manure based on 1000 pound live weight.

	Lbs/day	% water	Total solids	Volatile Solids	BOD5	N	P	K
Dairy	82	87	10.4	8.6	1.7	0.41	0.17	0.33
Beef	60	88	6.9	6.0	1.6	0.34	0.25	0.29
Swine Finisher	132	91	6.0	4.8	4.79	0.45	0.33	0.36
Layers	52.5	75	13.25	9.25	3.5	0.75	0.625	0.35
Broilers	70	75	18.0	12.5	1.15	1.2	0.615	0.45
Turkey	47	74	12	9.1	2.1	0.68	0.24	0.27
WWTP Influent	3.35	80 est.	2.7	1.2	1.7	0.25	0.17	na

The effects of excess nutrient release into the watershed may cause eutrophication of water bodies with consequent degradation of potential uses of the water. Harmful organisms may bloom in response to the nutrient input causing problems with fisheries and human health. And in the case of the Mississippi River ammonia inputs to the Gulf of Mexico have led to the development of extensive anoxic zones. Control of nutrient loss is important to management of animal wastes.

3.2.2 Nutrient Content and Form from Poultry

3.2.2.1 Layers, Broilers, and Turkeys

Poultry is made up of three sub-types: layers, broilers, and turkeys. Broilers and turkeys are fed to optimize growth and development, while layers are fed to maximize egg production. Manure produced by these groups reflects these differences as well as differences in housing practices.

Manure production and manure handling is similar in broilers and turkeys, resulting in similar nutrient concentrations. The floor is covered with moisture absorbing bedding and is ventilated. This airflow removes ammonia and other gases leaving a nitrogen depleted manure. Broiler manure as excreted has a nitrogen content of 401 lb/yr/1,000 lbs of animal mass (USDA, 1998); broiler house litter has a nitrogen content of 27 lb/yr/1,000 lbs of animal mass (USDA, 1992). Some of this decrease in nitrogen may be explained by solubilization as when bedding is washed off the floor rather than scraped as shown by the decrease in phosphorus and potassium from 117 and 157, respectively, to 113 and 111 lb/yr/1,000 lbs of animal mass. The much larger percent loss of nitrogen results from off-gassing of ammonia.

3.2.2.2 Layers

Layer manure production often includes no bedding, and it is handled as raw dried manure or water flushed manure. Water flushing manure results in dilution with a concurrent increase in volume. Raw manure contains 308, 114, and 120 lb/yr/1,000 lbs of animal mass of nitrogen, phosphorus, and potassium (USDA, 1998). Dry manure may lose up to 50% of the nitrogen content as volatile ammonia. Poultry manure dries rapidly and may be scraped off from flooring and stored dry in stacks or cakes. Dilution in lagoons and slurries may result in concentration reduction to as little as 10% of the raw manure value (USDA, 1992).

3.2.2.3 Nutrient Content and Form from Swine

Swine manure is typically collected in lagoons, pits, or both (Svoboda 1995). Nitrogen loss in the water fraction of the lagoons due to aeration may be as much as 76-84% of the original nitrogen content. Phosphorus and potassium losses to accumulation in sludge may be 78-92% of the phosphorus and 71-85% of the potassium (Jones and Sutton, 1994). The phosphorus and potassium lost from the aqueous stream are found in lagoon sludge.

Generally speaking, boars and larger swine produce manure with a higher nutrient content. Values reported here are for grower-finisher operations as these are more representative of the life-long manure production of the swine. Typical values are nitrogen, 166; phosphorus, 48; and potassium, 117 lb/yr/1,000 lbs of animal mass. Water-washed floors result in wet manure, which is often stored in lagoons.

3.2.2.4 Nutrient Content and Form from Cattle

3.2.2.4.1 Dairy

Average dairy manure as excreted contains TKN 164, phosphorus 29, and potassium 102 lb/yr/1,000 lbs of animal mass (Lander, 1998). These wastes are typically water-washed and stored in lagoons with concurrent loss of 30-75% of the nitrogen content (USDA, 1992).

3.2.2.4.2 Beef

Beef feedlot wastes vary widely due to climate, diet, feedlot surface, animal density, and frequency of cleaning. Feedlots are typically scraped and the resulting waste is stored on the ground. Aged manure loses, on a dry weight basis, up to 60% of the nitrogen, 50% of the phosphorus, and 35% of the potassium (Mathers, 1972) to volatilization, runoff, or leaching.

3.3 Manure Management Practices

3.3.1 Wet Manure Management

Liquid or slurry systems include wet barn washing, under-building or lagoon storage followed by spray application, injection, or gate and channel application onto the land. Liquid manure systems handle material with solids content below 10%. Gravity flow systems work well for movement of wastes from production to storage facilities, such as lagoons. Operations that require pumping to move wastes should have solids content of less than 4%. Liquid wastes are amenable to treatment in digesters. The digesters may be well engineered and controlled systems to increase efficiency, or enhanced lagoon storage to enable a lower intensity treatment, with longer treatment time. These systems are most amenable to recovery of fuel value from methane production. Swine and dairy operations commonly use wet manure management and are therefore potentially at risk from nitrogen percolation to groundwater and airborne stressor transport, especially if wastewater is sprayed. Liquid systems are described in more detail in the land application section.

3.3.2 Dry Manure Management

Solid manure systems include mechanical scraping of waste to clean out barns, pile storage and land application using a manure spreader, either truck-mounted or tractor-drawn powered spreaders. Dry systems include the manure plus any bedding material used. Typical bedding may be wheat straw, corn stover, corn cobs, sawdust, or any absorbent material. The bedding material absorbs water and changes the C:N ratio of the manure. The resultant material may then be suitable for composting with little need for adjusting carbon content.

Poultry and beef feedlot operations use dry manure management and so are more at risk from phosphorus application to land. Many CAFOs occupy only enough land for their day-to-day operations. The amount of manure produced in the CAFO may well exceed the capacity of the available land to absorb it. This is especially true when applications are based on phosphorus needs of crops rather than nitrogen. Offsite manure transfer may be a valuable way to expand the disposal area available. However, adequate record keeping and nutrient management is essential to avoid excess application to fields.

Typically, the smaller operations use familiar manure spreaders to distribute the manure in farm fields. Manure is loaded from the barn using a tractor-mounted scoop into a power driven spreader box or flail spreader. The spreader is driven to the field and the load distributed onto the land. The solid spreaders handle manure that is about 20 to 25% dry material, sometimes less. The material may be stacked with little or no liquid seepage. This type of manure is most easily treated by composting, should treatment be required before distribution. Incorporation of manure should be done as soon as possible after application to ensure N retention. Incorporation may not be done if the manure is applied to standing crops. The primary benefit of this system is relatively low cost for equipment. Evenness of distribution is not easily obtained. Timing of application is not generally done with nutrient management in mind. The small operator spreads

manure when other activities are not pressing. Common times are: fall after harvest of corn and soybeans, winter, spring after planting is done, and summer after wheat is harvested. The largest risk would come from the winter application on frozen soil. Incorporation would not be feasible, and upon spring thaw and rainfall, runoff could produce significant losses of material to receiving water.

4 WATERSHED STRESSORS IN CAFO WASTE

The pollutants potentially leaving the CAFOs may affect watersheds directly or indirectly. The most often cited stressors affecting watersheds include nutrients, pathogens, sediments, EDCs, antibiotics, and metals. Direct effects occur when wastes flow directly into a receiving water as a result of poor storm water management or catastrophic failure of containment facilities. Indirect effects occur when wastes have been applied to a field and are subsequently moved into waterbodies by runoff after rainfall, percolation into groundwater with subsequent entry into streams or tile drain lines, wind driven movement, or volatilization and redeposition as in the case of ammonia.

The nutrient content of the manure generated on the CAFO is one of the most significant problems. Nitrogen in the waste may be transferred in the environment two ways. Ammonia may be volatilized from the waste directly into the air and generate odor and downwind deposition problems. Nitrate generated in the soil applied waste may enter surface or groundwater and may exceed the national drinking water limit of 10 mg/L to cause health problems in young children.

Phosphorus in waste may easily exceed crop requirements for a given year on a localized basis. If continual applications are made year after year, the soil becomes saturated with P and the potential for runoff losses and groundwater losses greatly increase.

The soil, if eroded will contribute to stream degradation by eutrophication. Erosion of soil onto which manure has been applied, may contribute to other environmental problems in waterbodies. Organic matter exerts an oxygen demand leading to a depression of dissolved oxygen. Solids, as either manure particles or eroded soil particles, increase the sediment load in streams and may unduly shade some parts of the stream. Other habitat effects will be associated with increased sediment load.

Microorganisms associated with manure may present a significant risk to health. The population of several known pathogens may be quite high in manure. Runoff from land application sites may carry large numbers of organisms into streams. Recreational use of the streams may then bring people into direct exposure to large numbers of potentially pathogenic microorganisms. Several disease outbreaks have been associated with manure contamination of water or food that has been contacted by manure.

There are also concerns associated with the potential metal content of poultry or swine waste. Trace levels of arsenic are added to poultry feed to promote growth. Similarly, copper is added to swine feed for growth promotion. Antibiotics, hormone compounds, and pesticides are found in animal wastes, and the environmental effects of these compounds are largely unknown. The following sections are meant to summarize the most pertinent literature concerning nutrients and other stressors from CAFO manure. The literature in the area of nutrients and nutrients as pollutants is overwhelming. This is an attempt to limit the literature review to the citations that have the most impact on EPA's mission.

4.1 Nutrients

“Livestock wastes, which for present purposes are defined as liquid and solid excreta with the associated remains of bedding and feed and sometimes with water added, have long been ranked among the farmer's most valuable resources. For traditionally, the fertility of his land has depended in very large measure on the supply of such waste, sometimes dropped in his field by grazing animals or sometimes

stabilized in the steading into farmyard manure by the addition of straw. In the days of the agricultural revolution the efficiency of the yards as a ‘*manure factory*’ was one of the primary criteria of farmstead design. More recently and more drastically, a variety of agricultural changes have combined to convert, under certain circumstances, this potential asset (manure) into an increasing liability. The agricultural changes result from growing economic pressures to increase the animal outputs by an increase in the number of livestock carried per unit of land.” (ARC 1976)

4.1.1 Nitrogen

Animal waste contains nitrogen in organic and inorganic forms. The inorganic form is ammonia, and organic forms include urea and an array of organic compounds. Nitrogen compounds may move in a watershed in air, surface runoff, or through percolating groundwater. Any form of nitrogen may have an impact on a watershed because it is a major plant nutrient. Ammonia is immediately available to plants as ammonium ion. Ammonia may move as an air pollutant after volatilization from animal waste. In the soil, ammonia enters solution as ammonium ion that may be held on soil colloid exchange sites. Ammonium is formed when organic-N such as urea is metabolized either aerobically or anaerobically to NH_3 that ionizes in water to ammonium. Ammonia may lead to eutrophication, excessive oxygen demand in surface waters and fish kills, reduced biodiversity, objectionable tastes and odors, and growth of toxic organisms. Both forms of ammonia, NH_3 and NH_4^+ , are toxic to aquatic life, although NH_3 is more toxic to fish. Ammonia may be converted by nitrification to nitrite and nitrate. Nitrite is toxic to fish and most aquatic species. Nitrite does not accumulate in the environment because it is rapidly oxidized to nitrate naturally by aerobic bacteria. Nitrate is highly mobile and may easily leach downward through the soil profile to an aquifer. Nitrate is the most widespread agricultural contaminant in drinking water wells (U.S.EPA, 1998). A drinking water maximum contamination level (MCL) of 10 mg/L has been set for nitrate-N based upon its role in the “blue baby syndrome” or methemoglobinemia. Nitrate may be converted to nitrite by nitrate reducing bacteria found in the low acidity infant stomach. Nitrite may then attaches to fetal hemoglobin in human infants forming methemoglobin, which is ineffective as an oxygen carrier. This toxicity, if not treated, may be fatal (Goldstein et al., 1974). Figure 4.1 depicts processes primarily responsible for transformation of nitrogen compounds in sediments at the bottom of lagoons (collection ponds) or in a topsoil layer treated with animal manure.

Soil profile characteristics and management practices may significantly affect leaching of nitrate and ammonium in feedlots and crop fields (Saint-Fort et al., 1995). Whereas runoff is the primary mechanism for the transport of sediment bound and solution phase ammonium, groundwater flow is the primary contributor of nitrate to surface water from agriculture. (Follet, 1995). Spatial variability of nitrate in ground water and temporal fluctuation are related to seasonal recharge and hydrologic variations in the region (Halberg, 1986). High concentrations of nitrate in groundwater are associated with high permeability soil and aquifer material, such as permeable sand and gravel, karst limestone, or fractured rock (Hitt et al., 1999). In these landscapes, manure applied as fertilizer is susceptible to relatively rapid infiltration, thus contaminating ground water with nitrogen and/or phosphorus.

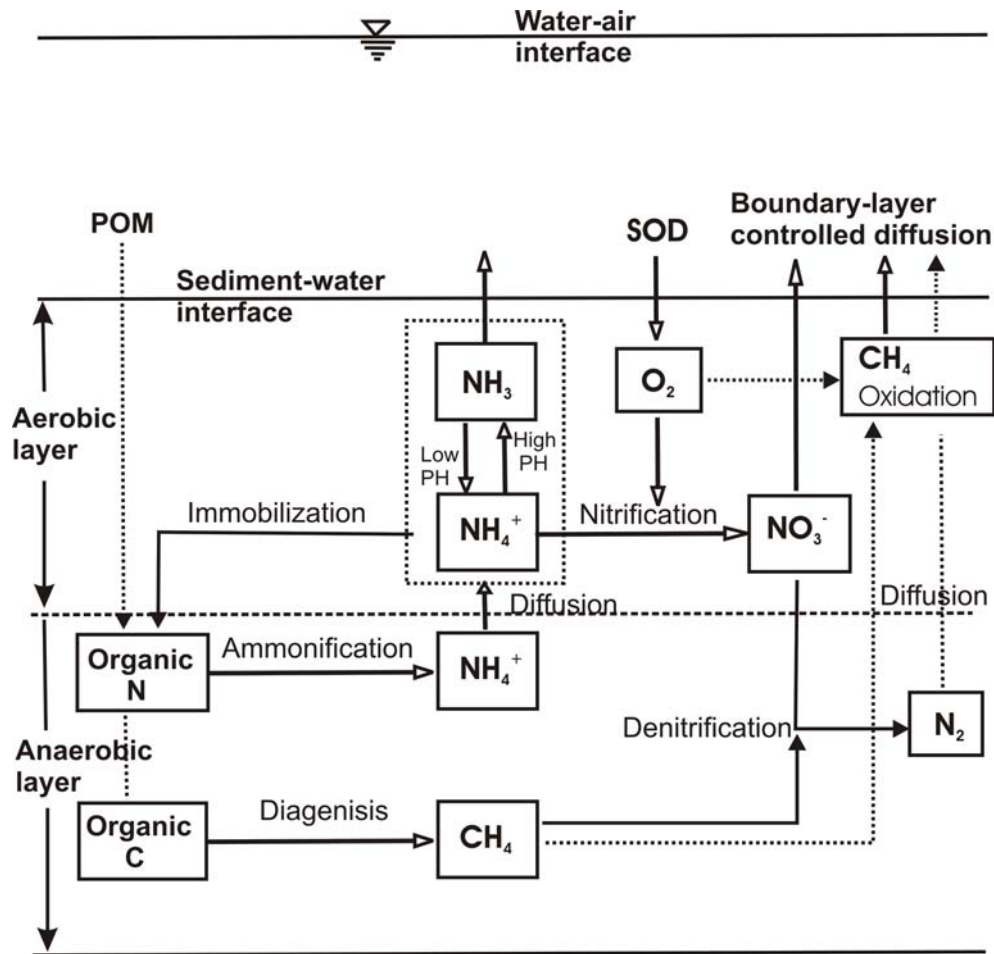

Figure 4.1. Depiction of carbon and nitrogen cycles in soils or sediments.

Leaky lagoons and below grade storage facilities are potential sources of nitrogen compounds that may enter groundwater. As structures age, the integrity of the walls and bottoms of the lagoon may be penetrated by burrowing animals, or the lagoon walls and bottoms may develop cracks from wetting and drying cycles as the water level in the lagoon changes (U.S. EPA, 2001). Rupture of lagoon seals may be attributed to drying of exposed embankments when lagoon levels drop or gas release from microbial activity in soil beneath the seal (Ciravolo et al., 1979; Parker et al., 1999). Short-circuits to natural filtering, such as uncapped or improperly capped wells and infiltration in vegetated filter strips adjacent to lagoons are potential sources of groundwater contamination (U.S. EPA, 2001). Groundwaters in areas of sandy soil, karst formations, or sinkholes are particularly vulnerable to nitrogen infiltration. Leaching of ammonia compounds is generally not a significant transport mechanism, because ammonium may be sorbed to soils, fixed by clay minerals and organic matter, or transformed into organic forms by soil microorganisms through the process of immobilization (Follet, 1995). Mineralization is a process whereby organically bound nitrogen is converted to inorganic mineral forms, (NH_4^+ and NO_3^-). Legume crops may fix atmospheric nitrogen by transforming (N_2) to ammonia. Ammonium adsorbed onto soil below liners in abandoned dry lagoons, through nitrification, may produce nitrate (Ham, 1999) that is potentially available for leaching into the deep subsoil and ground water. Two modes may dominate transport of pollutants in soils: 1) rapid advection through macropores; and 2) slow percolation through the soil matrix. The first transport mode, which is promoted by gravitational forces through macro-channels, is also referred to as preferential flow (Figure 4.2). The second mode is much slower and is governed by gravity drainage and capillary forces at

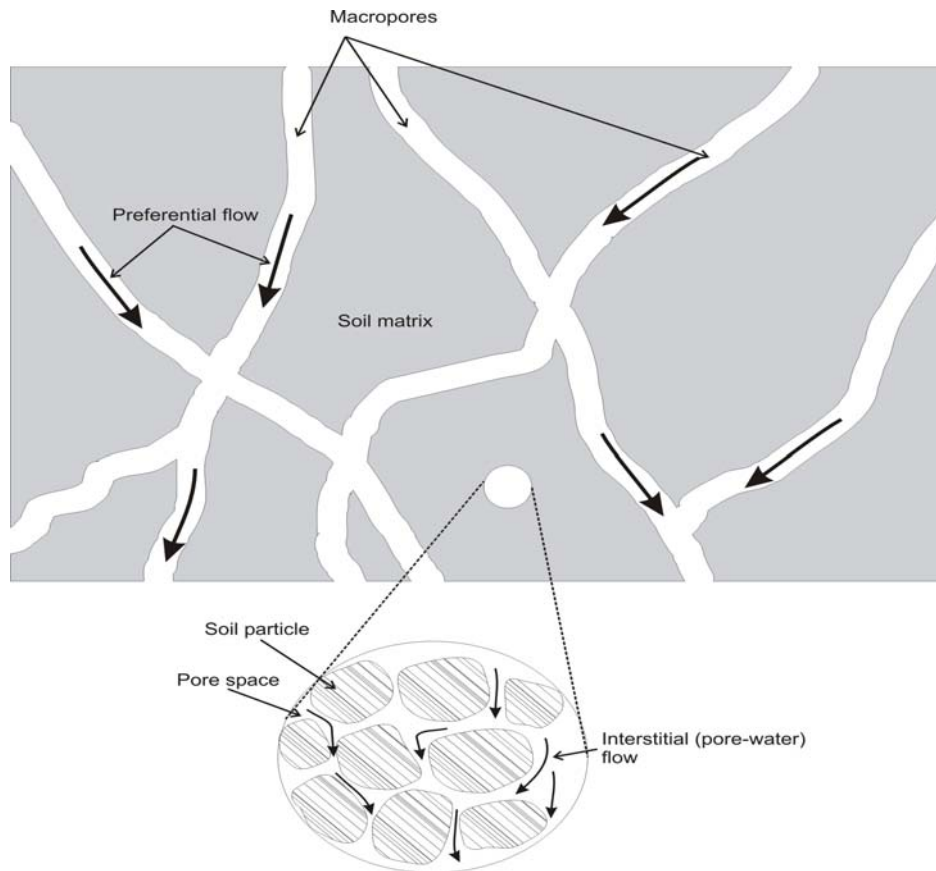

Figure 4.2. Diagrammatic illustration of preferential flow through macropores and interstitial (pore-water) flow in the soil matrix.

work through interstitial pore space. Preferential flow through macropores in soils beneath a waste lagoon may transport NH_4^+ or nitrate to ground water. Subsurface runoff and tile drainage are other transport pathways for nitrogen to surface waters.

Percolating water and leachate below lagoons may transport nitrate to ground water. Preferential flow through macropores and karst formations are also transport pathways to ground water. In heavily tile-drained watersheds most of the N added to surface water originates from tile drainage (Kovacic et al., 2000). In some areas nearly half of the applied fertilizer nitrogen may be discharged with tile-drainage water (Kanwar et al., 1983).

Nitrogen retention in the soil by adsorption of NH_4^+ onto soil colloids may constitute a source of NO_3^- to ground water (Ham, 1999). Urea and organic forms of N are also susceptible to leaching to ground water. Under anaerobic conditions, nitrate may be reduced to N_2 by denitrification, a primary process in reducing nitrate in ground water (Crandall, 1999). Denitrification occurs in the absence of dissolved oxygen and in the presence of chemically reduced compounds such as organic carbon or some divalent metals.

4.1.2 Phosphorus

Phosphorus exists as both organic and inorganic forms in animal waste. Inorganic phosphate in manure is easily adsorbed to soil particles, and thus has limited leaching potential. Organic P compounds are generally water soluble and subject to leaching (Sweeten, 1991).

Organic phosphate may easily be metabolized to inorganic phosphate that is the form that is useful as a nutrient. Inorganic phosphate in surface water is a major contributor to eutrophication. Because most surface water plant and algal growth is rate limited by phosphate level, pollutant phosphate is of particular concern. In concentrations over 1.0 mg/L phosphate may inhibit floc formation in drinking water treatment plants (Bartenhagen et al., 1994).

Phosphorus is much less susceptible to leaching because of its adsorption onto soil particles and therefore, poses less of a threat to groundwater than nitrate. Adsorption-desorption reactions in the soil regulate the rate at which P may be released (Siddique et al., 2000). Phosphorus accumulation in topsoil from animal waste and fertilizers constitutes a sediment problem more than a groundwater problem because P binds to the most erodible soil components (clay, organic matter, and oxides of Fe and Al)(Sims et al., 1998). However, if continual applications are made year after year, the soil becomes saturated with P and the potential for runoff losses and groundwater losses increases greatly. Phosphorus leaching may occur in sand soils where over-fertilization and/or excessive use of organic waste have increased soil P levels in excess of crop requirements (Sims et al., 1998). Preferential flow through macropores (e.g. soil cracks, root channels, earthworm borrowings) may transport a significant part of the phosphorus by suspended soil material to tile drains (Øyegarden et al., 1977). Leaking from lagoons is also a likely source for groundwater contamination by phosphorus.

Environmentally significant export of anthropogenic P from agricultural soils by subsurface runoff begins with downward movement of P, either by slow leaching through the soil profile or preferential flow through macropores (e.g., soil cracks, root channels, earthworm borings). Dissolved inorganic P concentrations in subsurface runoff in artificial drainage systems may be higher than values associated with eutrophication of surface waters (Ryden et al., 1973, and Sims et al., 1998). P leaching may occur in deep sand soils, in high organic matter soils, and soils where over-fertilization and/or excessive use of organic waste have increased soil P values well above those required by crops. Leaching potential of P increases in soils with low concentrations of soil constituents that are primarily responsible for P retention, such as clays, oxides of Fe and Al, and carbonates (Sims et al., 1998). Mineralization of organic P and preferential flow through macropores and cracks caused by conservation tillage systems increase P concentration in drainage waters, including sediment-bound P.

4.1.3 Mineral Salts

Mineral salts of major concern in animal waste include the cations sodium, calcium, magnesium, and potassium and the anions: chloride, sulfate, bicarbonate, carbonate, and nitrate. These mineral salts, when applied repeatedly, may accumulate and increase soil ionic strength to levels that are toxic to plants and animals. Runoff may contribute to surface water salinization and leaching salts may affect ground water quality. Trace elements such as arsenic, copper, selenium, and zinc are often added to animal feed as growth stimulants and biocides. These when land applied may accumulate and adversely effect both human and ecologic health.

4.2 Pathogens

Animal manure is a potential source of pathogens. The organisms of concern in animal waste may be bacteria, fungi, protozoa, viruses, or worms. When released into the environment, these organisms may adversely effect human and animal populations. Although CAFOs are not the only source of these microorganisms, they are a major source of pathogenic contamination in most watersheds (Pell, 1997). Indeed, of the water bodies evaluated by the states, as required by the Clean Water Act, 36% of rivers were

unfit for swimming and/or fishing as the result of pathogenic contamination largely attributed to CAFO operations (USEPA, 2001). In addition, the source waters from which drinking water is obtained for up to 43% of the United States comes from waters that are impaired by pathogenic contamination from CAFO operations (USEPA, 2001). About 15% of the population of the United States obtains drinking water from individual wells. When wells are located in areas hydrologically connected to CAFO operations, individuals using these wells may be exposed to pathogenic organisms present in the groundwater. Without purification, this may result in illness. CAFOs are likely to release pathogens into the environment for several reasons. First, because of the large number of animals kept in CAFO operations, the likelihood that one or more of the animals is infected with one or more pathogens is very high (Clinton, et al. 1979, Pell, 1997, Wesley et al. 2000). Second, because of the large volume of waste produced, manure may not be disposed of on-site in such a way that the pathogens will be killed or inactivated. Without treatment to reduce pathogen loads, storage and disposal practices will only serve to disseminate the microorganisms more widely in the environment.

Conventional water treatment is adequate to prevent the entry of bacterial contaminants into public drinking water supplies. Protozoan contaminants are usually in the form of cysts that are very resistant to chlorination. Drinking water treatment needs to be designed and operated properly to remove *Cryptosporidium* oocysts (Patania et al., 1995). Filtration through sand filters is usually necessary to remove protozoan cysts.

For the purpose of this RME only selected pathogenic organisms known to have a significant impact on human health or the environment and that are likely to come from CAFOs will be discussed. Before beginning a detailed discussion of these organisms, however, we will first discuss pathogenic organisms in general, their effects when released into the environment, and finally, relate the organisms to the CAFO species that is most likely the reservoir for each organism.

4.2.1 Pathogens of Concern at CAFOs

More than 130 microbial pathogens have been identified from all animal species that may be transmitted to humans by various routes (USDA, 1992; USEPA, 1998). Of these, 24 pathogens are likely to originate from animal populations. Historically, fewer than ten have caused significant disease outbreaks among humans. Potential environmental exposure to human populations extending beyond animal handlers exists for cryptosporidiosis, giardiasis, campylobacteriosis, salmonellosis, colibacillosis, leptospirosis, listeriosis, and yersiniosis; and many large-scale outbreaks have been attributed to each of these pathogens. Pathogens include bacteria, fungi, viruses, helminths (parasitic worms), and protozoa. Not all pathogens are present at every CAFO. Understanding the distribution of pathogenic organisms makes it easier to design strategies that will reduce risk. Table 4.1 lists commonly occurring diseases and the animals that are associated with these diseases. A general discussion of each of these classifications follows.

4.2.1.1 Bacteria

Bacteria are single-celled, prokaryotic microorganisms that are capable of causing disease in larger organisms, although most bacteria are non-pathogenic. They may grow and proliferate within higher organisms and are shed in feces. The presence of large volumes of feces in and around animals in CAFOs provides a breeding ground for many bacteria. The bacteria that have been shown to have the widest environmental impact when released into the watershed include *E.coli* 0157:H7, *Salmonella*, *Campylobacter*, *Yersinia*, and *Listeria*. The primary concern is that disease outbreaks may occur after

Table 4.1 Diseases and animals commonly identified as sources of the causative organisms.

Disease	Hogs	Poultry		Cattle	
		Turkeys	Layers	Beef	Dairy
Colibacillosis				*	*
Salmonellosis	*	*	*	*	*
Campylobacteriosis		*	*	*	*
Listeriosis				*	*
Yersiniosis	*				
Protozoa				*	*
Cryptosporidiosis				*	*
Giardiasis				*	*
Fungi					
Viruses	*	*	*	*	*
Helminths					
Endotoxins	*	*	*	*	*

contact with these organisms via swimming, eating shellfish, eating contaminated food, or drinking contaminated water.

4.2.1.2 Fungi

Fungi are either single celled organisms or multicellular, eucaryotic organisms that may cause disease in other organisms. Fungal diseases are commonly difficult to treat and may persist for long periods of time. Common diseases include candidiasis, histoplasmosis, aspergillosis, and dermatomycosis.

4.2.1.3 Viruses

Viruses consist of nucleic acid molecules packed within a surrounding protein coat. Viruses only actively replicate when they have invaded a host cell. The virus genes take over the host cell metabolism to make more virus particles at the expense of the host cell. There is some evidence that reoviruses and many enteroviruses may be transmitted from animals to man. Also, a number of rotaviruses are known to cause diarrhea in both cattle and humans. Among farm workers, vesicular stomatitis is frequently transmitted from sheep to humans, and the potential spread of cow pox virus (vaccinia) to humans was the basis for the classical immunological practice of vaccination. Present day surveys indicate that rabies is more likely to be transmitted from cattle to man than from either cats or dogs. At this time much less specific information is known about the actual transmission of viral diseases from livestock to humans.

4.2.1.4 Helminths

Intestinal parasitic worms occupy space in the host organism's intestinal tract. The worms absorb nutrients from the host and thereby create a burden on the host. The prevalence of worms has declined in the United States. Transmission is frequently through oral-fecal routes or from exposure through food contaminated with manure.

4.2.1.5 Protozoa

Cryptosporidium parvum: Among humans cryptosporidiosis is caused by the protozoan parasite, and it has recently been determined that there are two separate genotypes, Type 1 (human) and Type 2 (bovine), that can cause human infections. For the Type 2 genotype, the infective dose may vary from 10 to

1000 oocysts and infection is generally more severe in children and immuno-compromised individuals. Virtually all cattle herds carry some level of cryptosporidiosis, and persistence and spread in the environment is aided by passive transfer from rodents and birds. Infected animals can shed more than one billion oocysts per gram of manure. Many large-scale waterborne outbreaks have occurred in the United States. Conventional drinking water disinfectants such as chlorine and chlorine dioxide are not effective in killing *C. parvum*. The standard water treatment processes of coagulation, flocculation, and filtration are thought to be effective in removing this parasite when operating normally.

***Giardia lamblia*:** Giardiasis among humans may be traced to many possible sources including foodborne and waterborne transmission. It has been estimated that 2% of the population has been infected with this organism, and more outbreaks result from a waterborne origin than those caused by contaminated food sources. Wild animal populations such as deer, beavers, and bears may be the cause; however, more than 50% of dairy and beef cattle herds in the United States are infected with this organism. Infection may result from ingestion of only one oocyst, and once diarrhea occurs it may last up to two weeks. An ELISA assay for the detection of oocysts is readily available, and a vaccine for giardiasis is available for dogs and cats.

4.2.2 Disease Descriptions

Some of the diseases involved in significant waterborne disease outbreaks are summarized below.

***Enterohaemorrhagic Colibacillosis (Escherichia coli (EHEC) O157:H7)*.** There are many serotypes of *Escherichia coli* from animal sources that may infect humans. This group of diseases is referred to as colibacillosis. CAFOs, specifically cattle operations, may be sources of the organisms. However, among the various enteropathogenic and enterotoxigenic forms, *E. coli* O157:H7 clearly has the most serious manifestations. The hemorrhagic-toxigenic symptoms may often lead to death in 5-7% of infected individuals. The infective dose is thought to range between 10 and 1000 organisms. Contamination with cattle feces is known to be the most likely source of infection in the U. S. with foodborne infections ranking highest; however, waterborne and recreational exposure is also associated with this disease. Interestingly, outside of the United States isolation of cultures of *E. coli* O157: H7 is associated with sheep. Although swine and poultry carry many strains of *E. coli*, the specific Strain O157:H7 has not been isolated from these farm species. Three *E. coli* outbreaks (one in Montana in 1995, one in Illinois in 1996, and one in Connecticut in 1996) were traced to organic lettuce growers. It is suspected that the lettuce was contaminated by infected cow manure (Nelson, 1997).

***Campylobacteriosis (Campylobacter jejuni)*:** This organism is the leading cause of bacterial diarrhea in the United States, the most common source being chickens, or more correctly, fecal contamination of poultry meat. This organism is also commonly transmitted by cattle, birds, and even flies. While the digestive tract of chickens contains many species of *Campylobacter*, it appears that most human infections are caused by four thermophilic strains of this organism. *C. jejuni* causes a watery diarrhea that is only occasionally bloody. Other symptoms include fever, abdominal pain, nausea, headache, and muscle pain. The illness usually lasts two to five days, but reinfection is common and treatment with antibiotics (preferably erythromycin) is not usually necessary. Surveys show that 20-100% of retail chickens are contaminated. When human outbreaks occur they are usually small (less than 50 individuals) although one large outbreak (2,000 people) occurred in Bennington, VT in 1978. Guillain-Barre syndrome may occur as a sequel to this infection as well as meningitis, recurrent colitis, and acute cholecystitis, but these occurrences are rare. Although chickens are the primary animal species associated with this organism, transmission from infected milk is relatively common.

Yersiniosis (*Yersinia enterocolitica*): This organism is a gram-negative rod that is often isolated from wounds, feces, sputum, and mesenteric lymph nodes. CDC estimates that 17,000 cases occur annually in the U.S. It is one of the three most significant microbes that can originate from large swine operations. Yersiniosis is frequently characterized by diarrhea and/or vomiting, fever, and abdominal pain. Similar to Salmonellosis, postenteritis arthritic conditions occur in 2-3% of the affected individuals.

Listeriosis: The CDC estimates that approximately 1600 cases of listeriosis occur each year with 500 resulting in death. It is believed that cattle that are being fed silage are much more likely to harbor this organism. Two separate clinical disease patterns may follow infection with *Listeria monocytogenes*. The more mild form is commonly referred to as gastrointestinal listeriosis and is characterized by a rapid onset of diarrhea, abdominal cramps, and nausea. The more serious form of the disease is referred to as listeriosis. Symptoms include septicemia, meningitis, encephalitis, and intrauterine or cervical infections in pregnant women resulting in spontaneous abortion (2nd or 3rd trimester), or a stillbirth. Gastrointestinal symptoms have been epidemiologically associated with use of antacids which significantly lower the infective dose.

Cryptosporidiosis: Many large-scale waterborne outbreaks have occurred in the United States. Particular attention is focused on the outbreaks in Milwaukee, WI and Carrollton, GA in which 400,000 and 17,000 persons, respectively, were infected. In another incident in Maine, a few hundred children were sickened by *Cryptosporidium*. The source was fresh-pressed apple cider made from apples gathered from a cow pasture (Millard et al., 1994). Conventional drinking water disinfectants such as chlorine and chlorine dioxide are not effective in killing *C. parvum*. The standard water treatment processes of coagulation, flocculation, and filtration are thought to be effective in removing this parasite when operating normally.

Giardiasis: *Giardia lamblia*: See Above

4.2.3 Effects of Pathogen Pollution

There is ample evidence that pathogens from agricultural operations have caused human disease outbreaks in the past. Ecological damage has also been indicated. Spread from animal to animal at the CAFO is a concern that individual operators have responded to with thorough periodic cleaning usually after one group of animals is sent to market and before another arrives.

Although more is known about the human diseases that may be caused by pathogens released from CAFOs, this section will also discuss the ecological effects of pathogens released into the environment.

An expert panel recently meeting on “Emerging Microbiological Food Safety Issues: Implications for Control in the 21st Century” concluded that control of manure has become a critical issue. Properly treated manure may be an effective and safe fertilizer, but untreated or improperly treated manure may contain pathogens that may reach fresh produce in the field or nearby water supplies.

The following text, tables, and references provide supporting evidence that farm animals held in CAFOS serve as an important reservoir for significant human pathogens and there are documented cases where serious disease outbreaks have occurred as a result of these animals’ manure containing pathogens. Table 4.2 shows examples of manure-related human epidemics. A brief summary of each incident follows. These outbreaks involved *E. coli* O157:H7, *Campylobacter*, and *Cryptosporidium parvum*. All cases summarized below resulted in serious illness and even some deaths.

Table 4.2 Examples of Manure-Related Human Epidemics

LOCATION	YEAR	PATHOGEN	IMPACT	SUSPECTED SOURCE	REFERENCE
Walkerton, Canada	2000	<i>E. coli</i> O157:H7 & <i>Campylobacter</i> spp.	6 deaths, 2300 cases	Runoff from farm fields entering town's water supply	Valcour, J. E., et.al. <i>Emerg Inf Dis.</i> , March 2002
Washington Co, NY	1999	<i>E. coli</i> O157:H7 & <i>Campylobacter</i> spp.	2 deaths, 116 cases	runoff at fairgrounds	<i>Public Health Dispatch</i> , CDC, 1999
Carrollton, GA	1989	<i>Cryptosporidium parvum</i>	13,000 cases	Manure runoff	Solo-Gabriele, <i>JAWWA</i> , 88; 76-86
Swindon & Oxfordshire, UK	1989	<i>Cryptosporidium parvum</i>	516 excess cases	runoff from farm fields	Richardson, <i>Epidemiol. Infect</i> 107:485-495
Bradford, UK	1994	<i>Cryptosporidium parvum</i>	125 cases	storm runoff from farm fields	Atherton, <i>Epidemiol. Infect.</i> 115:123
Milwaukee, WI	1993	<i>Cryptosporidium parvum</i>	400,000 cases, 87 deaths	animal manure and/or human excrement	MacKenzie, <i>N. Eng. J. Med.</i> 331:161
Maine & Others	1993	<i>E. coli</i> O157:H7	several illnesses	animal manure spread in apple orchard	Cieslak, <i>Lancet</i> 342:367
Sakai City, Japan	1995	<i>E. coli</i> O157:H7	12,680 cases, 425 hospitalized, 3 dead	animal manure used in fields growing alfalfa sprouts	Fukushima, <i>Pediatrics International</i> 41:213
Cabool, MO	1990	<i>E. coli</i> O157:H7	243 cases, 4 deaths	water line breaks in farm community	Geldreich, <i>Water Res.</i> 26:1127

4.2.4 Human Diseases: Examples of Manure-Related Human Epidemics, Case Studies of Problems and Potential for Problems with Pathogens in Animal Manure

4.2.4.1 Walkerton, Ontario

In May 2000, at Walkerton, Ontario, Canada, 2300 people were infected with *E. coli* O157:H7, and a smaller number were co-infected with *Campylobacter jejuni*. There were seven deaths, and more than 100 people were hospitalized. A direct link was made to cow manure as the source of the pathogens since a pasture occupied by cattle was located near the ground water source for the city's water supply.

4.2.4.2 Washington County Fair, New York

An outbreak of *Escherichia coli* O157:H7 and *Campylobacter* spp. also occurred among attendees of the Washington County Fair, New York in 1999. In this outbreak 116 cases were confirmed, 65 people were admitted to the hospital, 11 children developed HUS (Hemolytic Uremic Syndrome) and 2 children died. The link to cattle manure as the source was primarily through the isolation of these organisms from a shallow well on the fairgrounds and the knowledge that this organism is frequently found in cattle feces.

4.2.4.3 Carrollton, GA

In 1987 an estimated 13,000 people became infected with *Cryptosporidium parvum* due to a malfunction of the drinking water treatment plant. In addition to problems with the coagulation flocculation system, the filtration system was shut down periodically without backwashing the filters prior to each re-start. This failure of process control allowed *C. parvum* oocysts to freely pass through the filtration process. Carrollton, Ga. was the initial large-scale outbreak of cryptosporidiosis in the United States.

4.2.4.4 Wilshire, Swindon, and Oxfordshire, England

An outbreak occurred in Wilshire, Swindon, and Oxfordshire in January 1989, in which 516 cases were recognized, and 8% of the cases required hospitalization. The cause was traced to drinking water, and much emphasis was placed on the fact that the Thames River in this region drained cattle grazing areas. Extensive examination of the water treatment process was carried out, and a boil water order was issued. The outbreak(s) followed periods of heavy rainfall, and this factor supported the hypothesis that cattle manure was a source of the oocysts.

4.2.4.5 Bradford, England

In the community of Bradford, England, a city of 50,000 residents, 125 cases of cryptosporidiosis occurred over a 7-day period. All cases were confirmed by laboratory examination for oocysts. The average oocyst concentration in the city water supply was 0.019/L, and the outbreak occurred following a storm event in which excess water was draining from agricultural fields.

4.2.4.6 Milwaukee, Wisconsin

The largest waterborne outbreak of disease occurred March-April 1993 and resulted from a breach in treatment in one Milwaukee, Wisconsin water treatment plant. This event was responsible for 400,000 cases of illness and 87 deaths, with the deaths occurring among the immuno-compromised segment of the population. Both animal manure and material from a community wastewater treatment plant were implicated as likely causes of this epidemic.

4.2.4.7 Maine

There is evidence that a 1993 *E. coli* outbreak in Maine was the result of manure applications to a vegetable garden.

4.2.4.8 Sakai City, Japan

A massive outbreak of enterohemorrhagic *E. coli* O157:H7 infection occurred in July 1996 in Sakai City, Japan. The outbreak affected 12,680 school children and was caused by *E. coli* O157:H7. The pathogen was present in radish sprouts that the children consumed in a school lunch program. This is the largest outbreak due to this organism. From the original 12,680 children, 425 were treated at a local hospital, 121 developed the hemolytic-uremic syndrome. Three children died. This outbreak may be linked indirectly to cattle manure since the fields where the alfalfa sprouts were grown had been fertilized with manure.

4.2.4.9 Cabool, Missouri

In December 1989 and January 1990 contamination of the city water supply in Cabool, Missouri resulted in 243 cases of *Salmonella typhi* infection and resulted in 4 deaths. Cabool, MO is located in an

agricultural area of Missouri with large populations of beef and dairy cattle in the region. The source of drinking water is ground water, and prior to the outbreak, chlorination was not part of the water treatment process. Additional manure related infectious disease outbreaks have been reported by [Morgan et al. (1998), Solomon et al. (2002)], and Gordeiko et al. (1990). Rather interestingly, two Q-Fever outbreaks related to manure were reported: one in Germany [Reintjes et al. (2000)] and one in England [Jorm et al. (1990)].

While the above summaries concern outbreaks of disease serious enough to involve the public health authorities, other diseases, though less serious, are more common. It was estimated in 1998 that 2-4 million persons were infected with some form of salmonella (USDA, 1994). Salmonellosis is characterized by flu-like symptoms, possibly accompanied by nausea, vomiting, abdominal cramps and diarrhea. Except for *Salmonella typhi*, which is exclusively a human disease, other forms of salmonellosis do not have high mortality rates but do have high morbidity rates and are highly transmittable. Major foodborne outbreaks have been related to consumption of beef, poultry, homemade ice cream, and pork (USDA, 1994). It may also be present in eggs. The incidence of salmonellosis appears to be rising both within the U. S. and in other industrialized nations. *S. enteritidis* isolations from humans have shown a dramatic rise in the past decade, particularly in the northeast United States (6-fold or more).

4.2.5 Animal Diseases

While the common pathogens may be a risk to humans, they are also a risk to other animals. Wild animals moving near manure application sites may carry diseases to new areas. Most ruminants, deer, elk, and others will probably be sensitive to the same organisms that affect cattle. Poultry diseases may also affect other birds. Geese and ducks are known to carry *Cryptosporidium* and *Giardia*.

Distribution of manure beyond the production facility bears the possibility of serious environmental and economic consequences, such as, for example, if there is an asymptomatic carrier of a disease. The manure from that farm could spread the disease to several other farms receiving manure as fertilizer. The consequences could range from increased veterinary bills to treat affected animals to wholesale destruction of infected animals, depending on the disease being spread. Biosecurity of farms has become an important issue with the USDA publishing several guidelines for farms to help secure production facilities from external contamination. Not all pathogens are present at every CAFO. Understanding the distribution of pathogenic organisms makes it easier to design control strategies that will reduce risk. Table 4.3 shows the sources of common zoonotic diseases on farms as a function of livestock species (Cole, 1999).

Reservoirs for *Yersinia enterocolitica* include most domestic mammals, particularly swine. Reservoirs for *Yersinia pseudotuberculosis* include a wide variety of domestic mammals and fowl. The recently discovered hemorrhagic colitis strains of *Escherichia coli* belonging to the O157:H7 serotype are usually acquired after ingestion of either rare ground beef or raw milk. They have also been shown to be transmitted via water. These verotoxin-producing (shigatoxin) strains have been isolated from calves and pigs with enteric diseases and from retail pork and lamb. Reservoirs of *Campylobacter jejuni* include cattle, sheep, swine, dogs, and domestic poultry (USEPA, 1998). Both *E. coli* O157:H7 and *Salmonella* spp. are carried by ruminants, especially cattle, and at least one to five percent of cattle shed *E. coli* O157:H7 in feces. (Altekruse et al., 1997; Hosek et al., 1997).

Table 4.3 Sources of common zoonotic diseases on farms.

Pathogen	Poultry			Swine	Cattle	
	Broilers	Turkeys	Layers		Dairy	Beef
<i>Listeria monocytogenes</i>					▲	▲
<i>Cryptosporidium parvum</i>					▲	▲
<i>Giardia lamblia</i>					▲	▲
<i>Salmonella</i> sp.	▲	▲	▲	▲	▲	▲
Pathogenic <i>E. coli</i>					▲	▲
<i>Yersinia enterocolitica</i>				▲		
<i>Leptospira</i> sp.				▲	▲	▲
<i>Campylobacter</i> sp.	▲	▲	▲	▲	▲	▲
<i>Brucella</i> sp.				▲	▲	▲
<i>Erysipelothrix rhusiopathiae</i>		▲		▲		

The gram positive bacterium *Listeria monocytogenes* is widely distributed in the environment and is associated with decaying vegetation, soil, sewage, and feces of animals. Many cases of human listeriosis have been associated with consumption of fresh vegetables possibly contaminated with manure from ruminant animals. *L. monocytogenes* may grow on a variety of vegetables even at refrigeration temperatures. (Brackett, 1999) Therefore, the potential for introduction and transmission of *L. monocytogenes* from manure and soil amended with raw or poorly treated manure on produce may be greater than vegetables grown in soil amended with treated manure.

4.3 Antibiotics

Antibiotics are used extensively in animal production. Approximately 2.5 million kilograms of antibiotics per year are used on livestock in the United States (Kolpin et al., 2000). Of this amount, about 10% is used to treat active infections while the remaining nearly 90% is used for growth promotion and prophylactic care.

Antibiotics may be beneficial in agriculture, but there are growing concerns about the effects of antibiotics in the environment, especially the possibility of the increase in populations of drug-resistant microbes. An increase in drug resistant microbes could make it more difficult to treat diseases in animals and humans. Almost 50% of the antimicrobial agents in North America are used by agriculture. The majority of agricultural use is for growth promotion in farm animals. Growth promotion uses low doses of antibiotics that may lead to more bacterial resistance than higher doses used therapeutically (McGreer, 1998).

Antibiotic residue may be found in animal by-products (manure and urine). This waste may come in contact with humans, other animals, and surface and sub-surface waters through run-off and leaching. The concentrated use of antibiotics at CAFOs makes it more likely to have antibiotic residue and antibiotic resistant microbes in the vicinity.

Wide use of antibiotics may lead to development of resistance among the microorganisms that the antibiotics are being used to control. Antibiotic resistance develops in microbial populations due to the selective pressure exerted on the population by the antibiotic. If the level of antibiotic used is inadequate to completely eliminate the microorganisms from the animals some members of the population will survive. These organisms will continue to increase their resistance to the antibiotic until the antibiotics are no longer effective in controlling populations or diseases. The enzymatic capacity for resistance to antibiotics may be transferred in the environment by different mechanisms. Plasmids may be transferred directly from microorganism to microorganism, by bacteriophages, or upon cell lysis, leading to the uptake of free plasmids by other organisms. Increasing microbial resistance to antibiotics raises the possibility of hard-to-control animal sickness and require use of multiple antibiotics for treatment. Microbes could then become resistant to multiple antibiotics. Since the antibiotics may also be spread throughout the environment via manure and urine, other microbes that come into contact may also become resistant. This includes not only microbes that lead to animal diseases but to human maladies as well. Since the antibiotics used for animals are often the same for humans, different antibiotics may have to be used to fight the resistant microbes. One possibility to prevent this particular problem would be to limit the use of “human” antibiotics on animals.

4.3.1 Case studies on the effect of antibiotics related to CAFOs on the environment:

4.3.1.1 Case 1 – Chesapeake Bay

In the Chesapeake Bay area, manure from a chicken CAFO was used to fertilize fields. The runoff from these fields fed into the Pocomoke River changing the ecology of the river. Recently an outbreak of *Pfiesteria piscicida*, which is toxic to fish and human health, was attributed to the influx of antibiotics from the field runoff. A study has shown that this strain of *Pfiesteria piscicida* found in the Pocomoke River is antibiotic resistant whereas other strains from similar rivers do not show the same antibiotic resistances (Isbister et al., 2000).

4.3.1.2 Case 2 – Iowa Swine Operations

A study conducted by the Iowa Department of Public Health on the effects of CAFOs on the environment showed the presence of antibiotics and antibiotic-resistant microbes in the earthen manure lagoons. The tests revealed an antibiotic in an earthen manure lagoon monitoring well. Four different antibiotics (tetracyclines, sulfonamides, β -lactams, and macrolides) were found in detectable concentrations (Table 4.4).

Table 4.4. Antibiotic Levels in the Lagoons and one Monitoring Well (adapted from Table 7) (Iowa Dept. Public Health, 1998)

Collection Sites (Farm)	Tetracycline (µg/L)	Sulfonamide (µg/L)	β -Lactam (µg/L)	Macrolide (µg/L)
Lagoon (1)	250	>20	<2	227
Lagoon (2)	11	>20	<2	<10
Lagoon (3)	150	>20	<2	60
Lagoon (4)	68	>20	3.5	<10
Lagoon (5)	66	>20	2.1	81
Lagoon (7)	540	>20	2.1	275
Lagoon (8)	110	>20	2.9	15
Monitoring Well (8)	<1	7.6	<2	<10

E. coli, *Enterococcus*, and, *Salmonella* were obtained from the lagoons, wells, and drainage ditches on the sites. All these microbes showed varying antibiotic resistance (Iowa Dept. Public Health, 1998).

4.3.1.3 Case 3 – Shoal Creek

Researchers studying bacteria in Shoal Creek, located in Barry County, Missouri, found detectable concentrations of antibiotics in the creek. This northwest section of the county produces 33 million broiler chickens and 300,000 turkeys annually. The antibiotic source was found to be a chicken CAFO located upstream from where the antibiotics were found. Antibiotics used to treat both animals and humans as well as human only (located downstream of sewage plant effluents) were also found. Further study on the impact of the antibiotics to the watershed and ecological structure of Shoal Creek is on-going (Penprase, 2001).

4.3.1.4 Case 4 – A National Reconnaissance

The U.S. Geological Survey tested water samples from 139 streams in 30 states in 1999 and 2000. The selection of sampling sites was biased toward streams susceptible to contamination (i.e., downstream of intense urbanization and livestock production). The samples were tested for pharmaceuticals, hormones, and other organic wastewater contaminants. Of the 95 organic wastewater contaminants tested, approximately 20 antibiotics were measured and only eight were not found in the samples (however, some of them may have been present in the stream sediment due to “their apparent affinity for sorption to sediment.”

Figure 4.3 shows the frequency of detection and percent of total measured concentration for the contaminants, by category (Kolpin, et al. 2002).

The widespread use of antibiotics in agriculture, especially CAFOs, is now becoming an area of investigation in the United States.

4.4 Endocrine Disrupting Chemicals Associated with Concentrated Animal Feeding Operations

Endocrine disruptors are a class of chemicals of growing interest to the environmental community. The U.S. Environmental Protection Agency’s (EPA) Risk Assessment Forum defined an endocrine disrupting chemical (EDC) as “an exogenous agent that interferes with the synthesis, secretion, transport, binding, action, or elimination of natural hormones in the body that are responsible for the maintenance of homeostasis, reproduction, development and/or behavior (EPA 1997)”. Most of us are more familiar with chemicals of concern that have a specific health outcome such as lung cancer. However, EDCs are a class of chemicals defined by their mode of action and may result in a variety of health outcomes. For example, an EDC may initiate a health-related outcome in humans or wildlife by binding to and stimulating estrogen or androgen receptors.

Steroid hormones are chemicals of concern to endocrine health associated with CAFOs. Steroid hormones are used by many animals to facilitate the control of their body systems. Mammals, birds, reptiles, and fish produce virtually the same steroid hormones and possess receptors that bind the steroids to receive their control messages (McLachlan 2001). In this section, the term hormones will refer to steroid hormones. Until risk assessments are completed, it is assumed that all endocrine active compounds that have the potential to interact with the environment are chemicals of concern. Thus, the chemicals of concern are those hormones naturally produced and excreted by animals and those hormones administered to animals as drugs and are excreted. These animals remove hormones from their bodies by excreting them

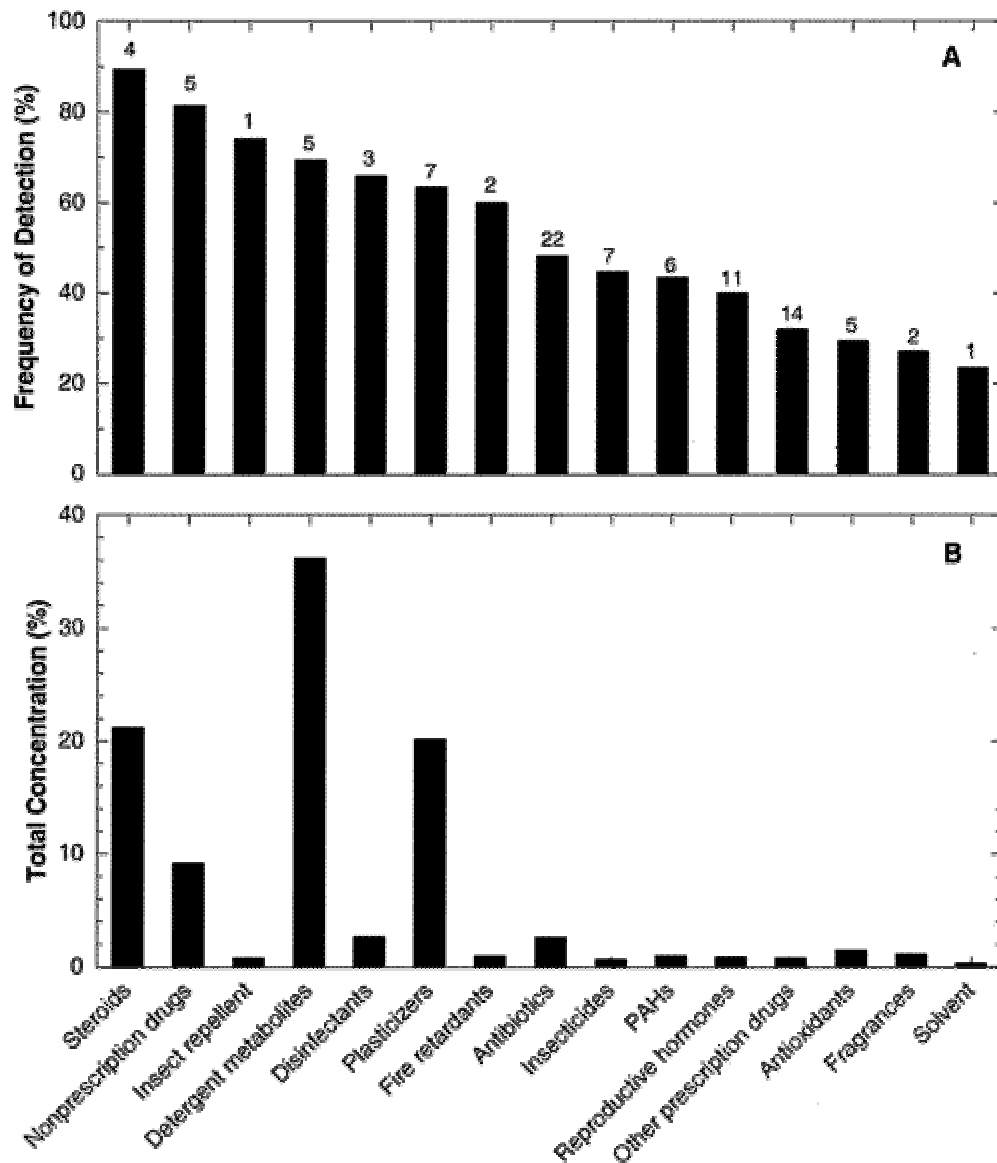

Figure 4.3. Frequency of detection of organic wastewater contaminants by general use category (4A), and percent of total measured concentration of organic wastewater contaminants by general use category (4B). Number of compounds in each category shown above bar (Kolpin, et al., 2002).

in urine or feces. Many of the methods of storage, treatment, and disposal of animal wastes at CAFOs allow contact of the waste with the environment. Since many animal species respond to the same hormones, it may be possible to disrupt the natural state of the endocrine systems in wildlife exposed to waste from CAFOs. If CAFO-generated hormones are transported to water bodies (surface or ground water), exposure to humans may be possible.

The classes of natural (biogenic) hormones that may be excreted by animals include estrogens, androgen, progesterones, and thyroid hormones. Although ideally all hormones would be considered in this risk management evaluation, there is almost no information available about natural hormones and animal feeding operations other than estrogens and, to a lesser extent, androgens. There is no information available

on CAFOS and thyroid hormones. Thus, the focus of this section will be on natural estrogens and veterinary hormones.

The chemical structures of the primary natural estrogens are shown in Figure 4.4. Here, they are shown in their biologically-active forms. Generally, hormones the body wishes to excrete are conjugated with glucuronides or sulfonides. Conjugation eliminates their biological activity and increases their solubility in water. Most literature concludes that excreted, conjugated hormones are deconjugated relatively quickly in the environment by enzymes produced by common bacteria (Schiffer, Daxenberger et al. 2001). It will be assumed that hormones in contact with the environment are not conjugated. The most active estrogen is 17 β estradiol, while estrone and estriol are metabolites of estradiol with much less biological activity.

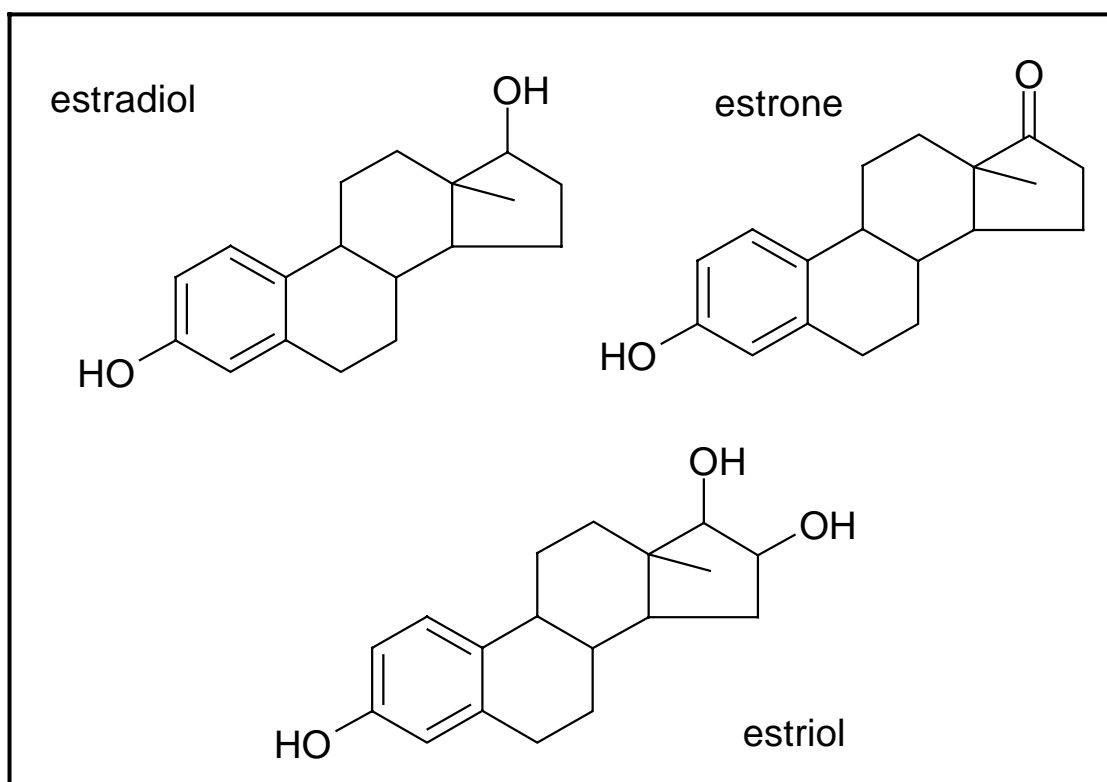

Figure 4.4. Structure of biogenic hormones.

4.4.1 Xenobiotic Hormones

The U.S. Food and Drug Administration (FDA) has approved the veterinary use of the six hormones (Table 1) and only for cattle and sheep (21 CFR, Chapter 1, Part 522). Patented forms of the natural hormones are often used in cattle and sheep production. These include estradiol benzoate (17 β -estradiol 3-benzoate) and estradiol valerate (17 β -estradiol 17-pentanoate), testosterone propionate, and various derivatives of progesterone, generically called progestins. Xenobiotic hormones administered to cattle and sheep include trenbolone acetate (TbA), melengestrol acetate (MGA), and zeranol. Zeranol is an estrogen mimic. TbA is hydrolyzed *in vivo* to the biologically active chemical, trenbolone-17 β (TbOH-17 β) (Schiffer, Daxenberger et al. 2001). TbOH-17 β acts as an androgen, and an antiglucocorticoid. TbOH-17 β

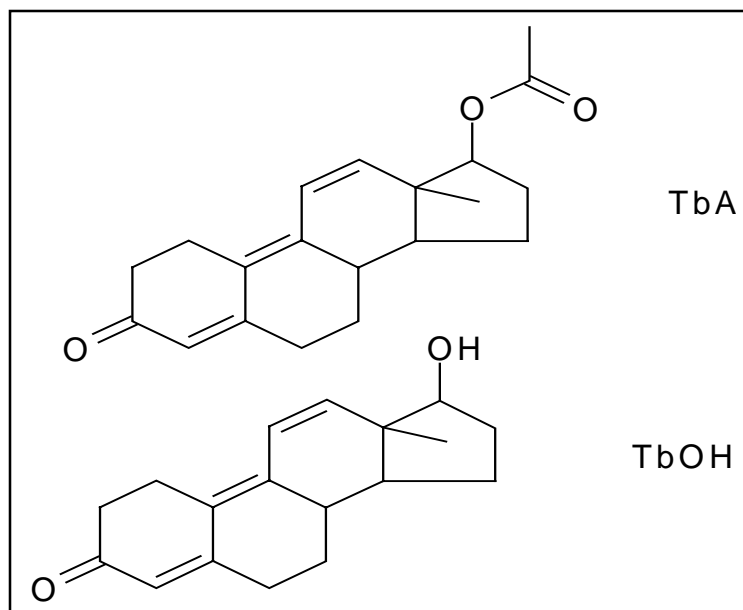

Figure 4.5. Chemical structure of Trenbolone acetate and hydroxide.

may be metabolized to TbOH-17 α which is 40 times less active than TbOH-17 β . Zeranone is an estrogen mimic. The chemical structures of these compounds are shown in Figure 4.5.

MGA is used for estrus synchronization or induction to improve feed efficiency and weight gain in heifers (Schiffer, Daxenberger et al. 2001). MGA acts as a progesterone and glucocorticoid.

The parent veterinary drug, trenbolone acetate (TbA), is metabolized to the biologically active chemical, trenbolone-17 β (TbOH-17 β) and TbOH-17 α . The β and α are isomers where the methyl and hydroxyl groups are *cis* and *trans*, respectively.

Since steroid hormones are the signal molecules of the endocrine system, organisms exposed to these hormones have the potential for adverse endocrine related effects. The consequences of excess estrogen in humans may be dramatic (Williams Textbook, 1998) and effects at low doses are possible (Anderson, 1999). Unintentional exposure of wildlife to estrogens has focused mostly on fish: vitellogenin production in male fish has been observed when exposed as little as 1 ng/l 17 β estradiol or 25 ng/l estrone (Routledge, 1998). Other estrogen-related health effects observed in wildlife include abnormalities in reproductive organ development and sex change. *In vitro* assays that measure binding to human steroid receptors have shown that TbOH-17 β binds to the human androgen receptor as strongly as the natural human androgen, dihydrotestosterone, and MGA binds 3.5-times stronger to the human progesterone receptor than progesterone itself (Bauer, Daxenberger et al. 2000).

4.4.2 Uses of Hormones in CAFOs

Farm animals generate, use, metabolize, and excrete natural hormones, the type and quantity depending on the animal, sex, and reproductive state.

The FDA has approved the veterinary use for cattle of the hormones listed in Table 4.5 in single hormone or dual hormone doses (21 CFR, Chapter 1, Part 522). The delivery of the hormones is typically

Table 4.5. Hormones Approved for Veterinary Use in Cattle

Hormone	Biological Activity	Commercial Forms
17 β -estradiol	estrogenic	estradiol benzoate, estradiol valerate
testosterone	androgenic	testosterone propionate
progesterone	progesteric	progestin
trenbelone acetate	androgenic	same
melengestrol acetate	progesteric	same
zeranol	estrogenic	same

accomplished by ear implant (although delivery of MGA in feed is approved by the FDA). The FDA has approved several dual hormone implants, including an implant containing 20 mg TbA and an implant containing 20 mg estradiol benzoate with 200 mg testosterone propionate. Data on the rate of use of these hormones in the United States were not found.

Arcand-Hoy *et al.* (Arcand-Hoy, Nimrod et al. 1998) estimated the use of exogenous estradiol (presumably the sum of the use of simple estradiol and the benzoate and valerate forms) to farm animals to be 580 kg/yr in the United States.

4.4.3 Release of Hormones to the Environment

Since hormones are present in animal excreted waste and in their bodies, excreted waste (urine and feces) and animal carcasses that come into contact with the environment must be considered as likely sources of hormones to the environment. Although the hormone content of waste has not been systematically studied, a relatively large total mass of hormones is released yearly given the estimated 291 billion pounds of manure generated annually in the United States (EPA 2001). The avenues of release of animal waste into the environment at CAFOs are described in detail in other sections of this RME. These releases may be associated with leakage from storage lagoons, runoff from composting operations, land application of waste, and other scenarios. There are very little data to quantify the release rates of hormones to the environment from CAFOs. One study found that chicken litter may contain > 100 μ g/kg estrogen and that runoff from a field receiving poultry waste contained up to 3.5 μ g/l estradiol (Shore, Cornell et al. 1995). A similar study found 1.3 μ g/l estradiol in runoff from land applied with poultry waste (litter) (Nichols, Daniel et al. 1997). Testosterone was found in rooster litter up to 670 μ g/kg (Shore, Harel-Markowitz et al. 1993). In another study, MGA and metabolites of TbA were measured in the dung of cattle given implants of MGA or TbA (Schiffer, Daxenberger et al. 2001). The maximum levels found in the dung were 7.8, 75, 4.3 μ g/kg of MGA, TbOH-17 α , and TbOH -17 β , respectively. Although there is little data, the U.S. EPA acknowledges that hormones should be considered in assessing the environmental impact of CAFOs (EPA 2001).

A recent news article quoted as yet unpublished work by U.S. EPA and university researchers regarding a study of the hormonal character of a stream associated with a cattle feedlot in Nebraska (Raloff, 2002). The research found that water collected downstream of the feedlot had significantly higher androgenic activity than water collected upstream.

4.5 Metals

4.5.1 Use of Metals in Animal Feed

Animals in CAFOS produce a great amount of manure that is applied to land as fertilizer. The metal content of animal waste is in question. Metals are being supplied to farm animals via diet. This review of the literature investigates the disbursement of the nutrient-rich excreta and the effects that are or may be encountered.

Metals in discussion here are copper, zinc and arsenic. While trace amounts of some elements are necessary for life, quantities above and beyond those amounts are fed to swine and poultry as growth promoters. Usually arsenic (often in the form of “roxarsone”, Christen, 2001) is fed to chickens for this purpose, even though arsenic is not a required nutrient; exaggerated amounts of copper and zinc (often in the form of CuSO_4 and ZnO or ZnSO_4 , respectively) are typically used in the swine diets. Possible adverse effects reported in the literature include the risk of phytotoxicity, groundwater contamination, and deposition in river sediment that may eventually release to pollute the water, the effect of manure application on grazing animals and also the result of using chicken litter for livestock feed.

The use of excess metals to promote growth is practiced in many countries. For example, Canada (DeLange, 1997), Great Britain (Nicholson, 1999), Japan (Eneji, 2001), France (Martinez, 2000), Germany (Rothe, 1994), Spain (Alonzo, 2000), Denmark (Tom-Petersen, 2001) and others have engaged in research to address issues similar to those of concern in the United States. Though the study parameters and methods of research may differ, overall, there are questions and conclusions that are nevertheless relevant to the demands of this discussion and are therefore taken into consideration.

The following table (Table 4.6) presents dietary/manure content data to give the reader an idea of the amounts of copper and zinc consumed by pigs when fed diets that achieve normal growth and those that promote growth. Arsenic is not a dietary requirement for poultry, the growth promoting level 5-10 ppm yields manure with 15-45 ppm (Muller, 2002; Chaney, 2002; Alonso, 2000; Ohio State Univ Bulletin, 1998).

Table 4.6 Copper and zinc in swine diets

Swine Diets (ppm)	Required Cu	High Cu	Required Zn	High Zn
Weanling/piglet	6	125-250	80-100	2000-3000
Manure (ppm)	~5.4	~113-225	~72-90	~1800-2700

4.5.2 Mobility of metals in soil

Mobility of the excreted metals has been addressed by some sources. Martinez (2000) examined the copper and zinc balances in soil after five years of repeated pig slurry applications. The results showed that most of the nutrient copper and zinc (80% of what was applied) remains in the top 0-20 cm of the soil layer. Tables 4.7 and 4.8 show soil analysis data for copper and zinc.

Table 4.7 Soil Cu balance after five years of repeated pig slurry application.

Soil Layer	Soil Cu content, mg/kg		EDTA Cu kg/ha		Increase in soil Cu	Recovery of Cu from slurry applied
	1991	1996	1991	1996		
0-20	2.8±0.3	35.1±2.8	7.3	91.3	84	45.8
20-40	2.2±0.5	12.6±2.6	5.6	32.8	27.2	14.8
40-60	1.3±0.3	2.2±0.7	3.3	5.6	2.3	1.3
Total	-----	-----	16.2	129.7	113.5	61.9

Table 4.8 Soil Zn balance after five years of repeated pig slurry application.

Soil Layer	Soil Zn content, mg/kg		EDTA Zn kg/ha		Increase in soil Zn	Recovery of Zn from slurry applied
	1991	1996	1991	1996		
0-20	2.7±0.8	64.1±5.8	6.9	167.0	160.1	60.2
20-40	2.3±0.7	15.4±2.4	5.9	40.0	34.1	12.8
40-60	0.8±0.3	1.8±0.5	2.1	4.6	2.5	0.9
Total	-----	-----	14.9	211.6	196.7	73.9

Gettier et al., (1988) is in agreement by finding that copper, when applied to the soil surface via pig manure, shows little movement through the soil profile (i.e., 0 – 20 cm) used in that experiment. (Also, see Table 4, data from *World Animal Science*, 1987.) It was reported that copper applied to soil generally results in a linear increase in extractable copper. Similarly, Mohanna et al., (1999) found a linear relationship between dietary zinc supplementation and the amount excreted. It has been advised that, with pig slurry application, immediate effects may not be recognized. Because metals may accumulate in the topsoil, it may be the longer term applications that reveal adverse effects (i.e., changes in soil biomass and herbage metal concentration) (Christie et al., 1989 and Eneji et al., 2001).

During an eight year period, Martinez et al. (2000), assessed the copper and zinc content of soil and drainage water in soil subjected to intensive pig slurry application. About 62% of the applied copper and 74% of the applied zinc remained in the soil as EDTA extractable forms. Only 0.05% and 0.6%, respectively, were present in the drainage water. A study of 18 soils in the Netherlands reported information concerning the correlation of organic matter and desorption of several metals (Impellitteri, et al., 2002). The results indicated that increasing pH increased soluble organic matter and Cu. Increased Ca flocculated organic matter and restrained Cu in solution. McBride (1994) stated that Cu added to soil will remain there for very long times. High organic matter increases mobility, but Cu is least soluble at pH near seven. Zinc may leach to lower levels of the soil if there are significant inputs of Ca to displace it from the exchange sites. Arsenic behaves in soil much like phosphate. That is, As only moves lower in the soil profile if the sorption capacity of the upper layers is filled. Based on this information, the amount of metals in the drainage may be very small, but some of the excreted metals do get carried into the groundwater, eventually making their way to a stream or river bed. Here, strewn about the sediment, the metals may be set into motion again as environmental conditions change (e.g., pH, redox potential, or high stream flow) (Lim et al., 1995). At that point, environmental consequences may become severe, even if they are delayed in time from the point of initial contamination. As, Cu, and Zn all have potential toxicity to plants and animals. Arsenic is found in soils from about 3.6 to 8.8 mg/kg. Copper is found in soils from about 14 to 29 mg/kg. And zinc is found in soils from about 34 to 84 mg/kg. Copper and zinc are both essential

elements for plant and animal life. The needed levels and the toxic levels will change as environmental conditions change. Arsenic is not an essential element and is more toxic to plants and animals than Cu or Zn.

4.5.3 Metals in plants

Christie et al. (1989), conducted a sixteen year study addressing herbage concentrations of copper and zinc that had reached 10 and 44 mg/kg, respectively. The purpose was to determine the toxicity to grazing sheep. See Table 4.9 for content data. While a very high rate of application (200 m³/ha/yr) was used to test extreme conditions, this rate produced enough soil copper and zinc accumulation sufficient to produce a toxic response from sheep (>10 mg/kg). Sheep are especially susceptible to excess copper, and a prolonged ingestion of just 15 - 20 ppm of copper may result in the occurrence of fatal hemolytic crisis. (World Animal Science, 1987)

Table 4.9 Cu and Zn in soil (top 5 cm), February, 1987 and herbage first cut of 1986.

		Copper				Zinc			
Treatment	pH	EDTA extract	Total	Extractable/total	Herbage	EDTA extract	Total	Extractable/total	Herbage
Fertilizer	5.1	4.8	14.8	0.32	3.9	4.4	55.9	0.08	13.5
Control	5.4	5.4	15.5	0.35	3.6	4.1	58.0	0.07	14.3
Pig Slurry, m ³ /ha/yr									
50	5.6	25.9	40.2	0.65	4.6	15.2	76.6	0.20	21.5
100	5.3	49.6	69.0	0.72	8.2	26.4	93.9	0.29	34.0
200	5.1	85.2	110.8	0.77	10.1	50.8	110.8	0.46	43.7
Cow Slurry, m ³ /ha/yr									
50	5.8	6.4	16.3	0.40	3.3	6.6	61.1	0.11	13.2
100	6.0	7.7	19.0	0.41	4.2	9.8	69.4	0.14	14.3
200	6.2	9.6	21.6	0.45	7.2	16.0	76.8	0.21	20.5
L.S.D. at 5% level	0.1	5.7	5.1	0.06	1.0	3.9	8.5	0.04	3.5

All values are mg/kg dry material. L.S.D. least significant difference (minimum difference to have significance).

While some studies proposed a threat of copper and zinc phytotoxicity, there was not an abundance of conclusive data. Tom-Petersen, 2001, explained that if the accumulation of copper in the soil reaches a toxic level, structure and function of the microbial community may be affected. But this source goes on to say that a lack of knowledge on the interaction between copper and the biota makes it difficult to assess the impact on a biological system. Likewise, Gettier, et al., 1988 states that while a high level of copper in soil is phytotoxic, the amount of copper that may safely be added to a soil system has not been well defined. World Animal Science, 1987, has indicated that zinc is partly added to high copper diets to counteract the accumulation of copper in animal tissue, and accumulation of either of these metals in soil could cause phytotoxicity in which the plant root system is affected first.

4.5.4 Metals in Animals

Alonso, et al., 2000, performed a study to determine whether pig slurry treated fields have an effect on the accumulation of copper and zinc in grazing cattle. It has been suggested that ruminants may be more at risk for copper toxicity because of their efficiency in absorbing trace elements across the gut, which may lead to toxic levels of copper in the liver. When the liver reaches saturation with copper, the copper is released quickly into the blood. In sheep, copper may cause fatal hemolytic crisis. This study concluded that, in areas with the highest pig densities, more than 20% of the cattle examined had hepatic copper levels exceeding the toxic concentration of 150 mg/kg fresh weight. Zinc liver levels, however, did not seem to be of any consequence.

The use of chicken litter (consisting of poultry manure, feathers, bedding, and spilled feed (Poore, et al., 1998) as livestock feed is yet another area of concern. While broiler litter has been used for over fifty years with no major problems, research performed at Virginia Tech. reported increases in arsenic and copper concentrations in the livers of cattle fed poultry litter. The arsenic concentration, however, returns to control levels within three days of withdrawal. Therefore, most states recommend a fifteen-day withdrawal period prior to slaughter. A related study indicated that while increased liver copper concentrations in cattle fed poultry litter without adverse effects have been reported, it was found in this study that the feeding of 1.13 kg CuSO₄/90.7 kg chicken litter to cattle resulted in chronic copper toxicosis. However, this condition may be reduced by supplementation of molybdenum and thiosulfate (Banton, et al., 1987). For reference, the level of arsenic in a typical chicken manure/litter is about 25 ppm. (Chaney, et al., 2000) A literature search for additional information regarding the role of arsenic contamination of soil via chicken manure (e.g., phytotoxicity, drainage water, sediment residue, etc.) was not fruitful.

Metals are excreted in various forms by animals. A common form of copper is the divalent ion that may form complexes with organic matter. Similarly, zinc has a divalent form that will also complex with organic matter. Arsenic more closely resembles phosphorus in its behavior.

4.5.5 Summary

The following comments are extracted from this review of dietary copper, zinc, and arsenic consumption by pigs and poultry and the distribution of these metals when excreted.

1. Copper and zinc are fed to swine in concentrations that exceed the minimum requirements to induce a growth promoting effect. In chickens, arsenic is used as a supplement for growth promotion; arsenic is not a dietary requirement in chicken feed.
2. Approximately 80-90% of the copper, zinc, and arsenic consumed is excreted.
3. Most of the excreted metals, contained in manure/slurry for land application, settle in the topsoil, approximately the first 0 - 20 cm of soil.
4. World Animal Science, 1987, reports that pig manure slurry, on the average, contains six times more copper than either poultry or cattle slurry. This presents a more striking danger of copper enrichment in those soils being fertilized with pig excreta.
5. Zinc added to a high copper diet helps thwart the possibility of copper toxicity.

6. In swine, the response to feed additives is greatest in starter diets (10-50 pounds). Higher levels of copper and zinc are typically found in the diet at this level. (KSU, October 1997)
7. A management plan needs to be established for each CAFO, on an individual basis, that takes into account variables such as soil type, soil pH, land area for manure application, level of waste water produced, animal density, anticipated metal output, etc.
8. There is a need to identify other growth promoters that would be non-toxic, or at least identify other forms of the metal compounds being used now that would be more bioavailable. For example, cupric citrate was found to promote growth at lower levels than cupric sulfate pentahydrate, resulting in less litter copper (Pesti, et al., 1996).

5 STRESSOR TRANSPORT

In the large quantities present at CAFOs, animal manure contains enough watershed stressors to be a significant source of environmental pollution. This section describes the ways in which the stressors in manure may be released into the environment. Overland transport in wet weather flow, subsurface transport to and through groundwater, and airborne transport and deposition are the primary pathways by which the environmental stressors in animal manure reach the environment. Understanding these pathways is important in developing strategies for managing the environmental risk posed by animal manure.

This section of the RME describes overland transport in wet weather flow, subsurface transport, air transport, and deposition in that order.

5.1 Transport Mechanisms

5.1.1 Overland Transport in Wet Weather Flow

The impact of wet weather flow and sediments from confined animal feeding operations (CAFOs) could be significant to maintaining a watershed environmental quality. Wet weather flow may provide conditions that result in the transport of contaminants and sediments to a receiving water. Sediment may prove a significant stressor to a watershed as sediment itself or as a medium for the transport of other stressors such as nutrients, pathogens, or chemical stressors. The processes responsible for the generation, transport, and deposition of sediment into a receiving water are primarily erosion, overland flow, and deposition. The effects of these physical and chemical processes will be dependent on the type of CAFO and the operations of facilities and their waste handling strategies. This section outlines some of the principal physical and chemical processes affecting sediment impacts from CAFOs, how these processes impact typical CAFO operations, and to identify areas of research as related to the reduction of sediment impacts on watersheds from CAFOs.

5.1.2 Physical and Chemical Processes Affecting Sediment Impacts

Three primary components of runoff are overland flow or surface runoff, interflow and groundwater flow. Overland flow is the portion of precipitation that flows over the ground surface until reaching a receiving point, such as a channel, stream, or pond. Overland flow occurs typically after the infiltration capacity of the soil has been exceeded. Interflow, also referred to as sub-surface storm flow, is the portion of precipitation that travels just under the soil surface until it reaches a receiving point. Groundwater flow, also referred to as baseflow or dry-weather flow, is the portion of precipitation that infiltrates the soil and percolates deeper until reaching the water table, and later potentially emerging as a component of stream flow downgradient from the infiltration zone.

5.1.3 Overland Flow

When precipitation first reaches the ground surface, it begins to infiltrate the soil. The rate of infiltration, called the infiltration capacity, decreases over time. This decrease is primarily due to the saturation of the soil void volumes. Once the soil becomes saturated, infiltration continues at an approximately constant rate, assuming that the precipitation event continues at an intensity equal to or

greater than the infiltration capacity. In general, the infiltration rate for clayey soils is less than that for sandy soils.

If the intensity and duration of precipitation is great enough to exceed the infiltration capacity of the soil, water will begin flowing over the ground surface as surface runoff. Some of this runoff flows into small puddles and ponds, and is termed depression storage. Runoff retained in depression storage may experience further infiltration or if the capacity of the depression is exceeded, overland flow will continue either until another depression, a stream, or receiving water body is encountered.

The wide variability in soil type, topography and vegetative cover within a watershed, coupled with the inconsistency of precipitation, results in some areas contributing a larger portion of runoff to stream flow and other areas contributing much less or not at all. The partial area contribution concept has been used to describe this behavior and it has been noted that in some watersheds as little as 1-3 % of the total basin contributes overland runoff to stream flow.

5.1.4 Interflow

The portion of infiltrated water that travels under the soil surface toward a receiving water body is interflow or sub-surface storm flow, and the movement of interflow is much slower than overland flow. This component of runoff is typically important in areas with permeable soil overlying less permeable soils or sub-surface materials, such as bedrock or clay, as may be the case of farm fields that are plowed and have a high percentage of organic material incorporated into the soil structure.

In many watersheds, the concept of variable source area contribution is important or dominates runoff closer to stream channels or receiving water bodies with shallow water tables, or where shallow impervious materials underlie the surficial soils. A variable source area in general is an area that expands or contracts depending on the precipitation event and initial soil moisture conditions, and occurs when soils become saturated from below due to a rising water table. As precipitation continues, the soils become saturated by the rising water table which in turn expands the area over which runoff will occur.

5.1.5 Groundwater flow

Groundwater flow, also referred to as baseflow or dry-weather flow may account for a substantial percentage of subsurface runoff from a watershed or to a receiving water body. Precipitation that continues to infiltrate the soil surface after the soil is saturated, and does not become interflow, percolates downward by capillary action and gravity until reaching the water table or an impermeable geologic unit. The area within a watershed, where infiltrating precipitation eventually reaches the water table and becomes groundwater, is termed a recharge area. Groundwater flows from areas of high potential (recharge area) to areas of low potential (discharge area). Recharge areas are typically topographically higher in elevation than discharge areas that are usually incidental with a stream, river, or pond.

5.2 How These Processes Impact Typical CAFO Operations

Runoff, and the various components of runoff have varying degrees of importance in the context of CAFOs. The area of consideration at the individual CAFO is important when determining if runoff may be a concern. Runoff may occur from several areas, including the roof of a barn or other type of shelter used to house animals, external feeding areas that may or may not be paved, and may or may not be diverted to a lagoon or holding pond, pasture lands used for animal grazing, and crop lands that receive animal waste as a nutrient source.

In this discussion, water that is used to flush animal waste generated inside a barn or shelter to a holding facility is not considered part of runoff. If this material is incorporated into the soil surrounding the CAFO, the materials in this water, both physical and chemical, will be susceptible to runoff processes.

Runoff may or may not have any associated impact or concerns. Depending on the flow path and material encountered during the generation of runoff, water has the ability to pick up physical and chemical components that may degrade the receiving waters. These potentially degrading compounds include sediments, nutrients, pathogens, EDCs, heavy metals, and pesticides. These various compounds are discussed in separate sections. Additionally, runoff has the ability to cause flooding.

Many conditions contribute to the generation of runoff including topography, geology, soil type and thickness, precipitation intensity, duration and form (rain versus snow), vegetative cover, climate and season, soil moisture, evapotranspiration, depth to groundwater, presence of vegetative buffers, condition of the land surface (recently plowed and plowing technique) and size of the field, farm or watershed in question.

5.2.1 Suspended Solids and Sediments (SSAS)

SSAS production from CAFOs may be attributed to three primary sources; direct erosion, loss of impoundment/lagoon sediments, and waste handling/disposal processes. Direct erosion may be an obvious source of sediment in certain CAFOs, such as beef cattle feedlots, dairy operations, or other outdoor operations. Erosion from these operations will be subject to erosion processes typical of other agricultural practices. SSAS from impoundments/lagoons may be controlled by the design of the impoundment/lagoon. Waste handling/disposal processes may also generate SSAS. For example, land application is typically used for swine waste. Though the waste will have undergone some preliminary settling during handling and storage, the application of the waste to agricultural fields may result in particles being applied to the field, as well as, the waste adhering to the SSAS generated from the erosion of the agricultural soils.

The natural processes of erosion results in a background sediment load to receiving waters. Erosion is the term used for the gradual wearing away of the earth's surface due to natural physical and chemical processes. Millar et al.,(1965), differentiates between geologic and soil erosion. Geologic erosion is defined as the erosion of the earth's surface under natural conditions when the land surface and the vegetative cover are undisturbed. Geologic erosion is a relatively slow process and natural in-stream processes are typically able to assimilate the sediment loadings that result. Soil erosion is defined as the unnatural erosion of the land surface, typically due to man's activities such as deforestation, tilling, or other activities. The natural processes of erosion may be significantly accelerated by man's activities. Research has been conducted on conditions and practices that affect soil erosion such as soil properties, the impact of typical agricultural practices, deforestation, and burning (Braskerud, 2001; Butler and Karunaratne, 1995; Carpenter et al., 2001; Haigh and Gentcheva-Kostadinova, 2002; Kondolf et al., In Press; Lau et al., 2001; Lisle et al., 1998; Martin-Vide et al., 1999; Midmore et al., 1996; Millar et al., 1965; Nash and Halliwell, 2000; Peterson 1999; Uri and Lewis, 1998; van der Werf and Petit In Press; and Woo et al., 1997). This research has focused on retaining topsoil and soil structure for maintaining or enhancing agricultural production. The impact of CAFOs with respect to SSAS has not been thoroughly considered.

In this document, erosion will be limited to that caused by water. Erosion by water is typically divided into four categories: splash, sheet, rill, and gully erosion. Splash erosion is the deterioration of the soil structure due to the impact of a raindrop onto the soil surface. The impact breaks down the soil structure and the water from the droplet carries away or erodes some of the soil. Sheet erosion is erosion

typically over a smooth, lightly sloped soil and results from overland flow. This results in a gradual uniform removal of soil particles. However, sheet erosion seldom occurs without forming rill erosion. Rill erosion is the result of pockets of water forming in small depressions. The water leaving these pockets form small rivulets of flow, which erode small channels into the soil. The small channels cut are called rills. Sheet and rill erosion are typically due to overland flow. Left unchecked, the small channels enlarge to form larger channels that eventually combine to form still larger channels. As these channels increase in size their water carrying capacity increases, which consequently results in a greater capacity to erode the soil. Once these channels work down through the soil structure, they form what is known as gully erosion. Gully erosion is the combined process of waterfall erosion, channel erosion, and freeze/thaw erosion. Gully erosion is easily identified and typically indicates severe neglect. This form of erosion may significantly add to the sediment load of a nearby receiving water.

Erosion generates the particles that are carried to the receiving water to become suspended solids and sediment. Once in the receiving water, in-stream processes control whether the SSAS are deposited or carried downstream to be deposited later. These in-stream processes are beyond the scope of this work and for the most part are not necessary to the issue of managing SSAS from CAFOs.

5.2.2 Stress due to SSAS

SSAS may act as a stressor directly on an aquatic system or indirectly by transporting particle bound stressors. As a direct stressor, SSAS may significantly increase the turbidity in receiving water. This increased turbidity may dramatically reduce the primary production of the water column by limiting the light penetration (USEPA, 2001b). Depending on the physical and chemical characteristics of the SSAS, the turbidity may persist downstream even with significant dilution and/or settling time. SSAS may also result in siltation of a receiving water. Siltation may result in a loss of critical habitat, loss of water carrying capacity, and increased need for dredging or other waterway maintenance.

SSAS may also serve as a significant source of particle bound stressors. Contaminants that are particle bound may increase the aquatic exposure in the receiving water by renewed exposure through resuspension and redeposition. These particle-bound contaminants may include nutrients, pathogens, metals, and organic contaminants. Nutrients such as nitrogen, phosphorus, and potassium may be carried by SSAS to a receiving water. CAFO wastes are typically high in these components (USEPA, 2001a) and depending on the chemical form of the nutrient, the SSAS may serve to transport these stressors. Pathogens are also found in CAFO wastes and may be associated with soil particles and sediments. The interactions between pathogens and SSAS are beyond the scope of this report. In addition, organic contaminants (such as EDCs, antibiotics, etc) trace metals, and salts may be associated with SSAS. These stressors are addressed in other sections of this document.

SSAS may also act as a stressor by reducing the available dissolved oxygen in a receiving water. The organic content of CAFO waste is animal specific. In general, beef/dairy waste has a high organic content in the form of undigested cellulose. Swine waste and poultry waste are lower in organic content. The organic content is important as it provides an organic substrate for microbial activity. This microbial activity uses available dissolved oxygen in the water column. If the oxygen demand exceeds the available dissolved oxygen (DO) and the rate of re-aeration, the DO may drop to levels that are critical for maintaining a viable ecosystem. The oxygen demand is commonly measured as either a biochemical oxygen demand (BOD), which is the oxygen demand required to biologically stabilize the biodegradable components, or a chemical oxygen demand (COD), which is the oxygen demand needed to chemically oxidize organic and inorganic components regardless of their biodegradability (Millar et al., 1965). With

all the considerations of efficient management of SSAS and other stressors, economic design constraints must be considered in the optimization of the design. The management strategies may not be so cost prohibitive that the CAFO operator cannot afford the management. In the economic considerations, the design should account for the impact on production, as well. For example, the design cannot be for a ten acre detention basin on a five acre CAFO.

CAFOs offer a challenge to manage their impact on the environment and the economic production of the animal product. However, the concentrated nature of their design offers an opportunity to engineer an efficient and economic management solution and in the end potentially to reduce the overall waste load to the environment from animal production whether confined or traditional.

5.3 Groundwater Transport

5.3.1 Statement of Problem

Storage and handling of animal waste in CAFOs and related agricultural practices are contributing to groundwater contamination, and may have severe impact on surface water quality, since 40 percent of the average stream flow is derived from ground water discharge as base flow (U.S.EPA 1993b in EPA-821-R-01-003). Dairy operations were identified as the major source of groundwater contamination by nitrate in excess of the MCL in the Chino Basin, California (U.S. EPA, 1998, Aton et al., 1988). This presents potentially widespread impacts, since water from the Chino Basin is used to recharge the primary source of drinking water for residents of heavily populated Orange County. In southeastern Delaware and the Eastern shore of Maryland, over 20% of wells were found to have nitrate levels exceeding the MCL (U.S. EPA, 1998, Ritter et. al., 1989). Measured nitrate levels in ground water beneath Delaware poultry houses have been as high as 100 mg/l (Ritter et. al., 1989). Fractured aquifers (e.g., karst terrains developed in carbonate rocks) underlie extensive, important agricultural areas in the eastern half of the United States (from Iowa, to New Mexico and Texas, to Florida and Puerto Rico, and to Pennsylvania and New York) are particularly vulnerable to nitrate by preferential transport (LeGrand and Stringfield, 1973). Evidence indicates that leachate from lagoons located in well-drained soils (e.g., loamy sand) may severely impact groundwater quality (EPA-821-R-01-003, Ritter and Chirnside, 1990), and that the use of manure in agriculture may cause bacterial contamination in karst aquifers (Boyer, 1999). Since rural areas in the nation generally rely on ground water as a drinking water source, they are at greater risk of nitrate poisoning than those drawing from public water supplies (U.S.EPA, 1998, Nolan and Ruddy, 1996). Nutrients, pathogens, salts, toxic metals, antibiotics, and hormones derived or excreted from animal waste and carcasses have the potential for groundwater contamination and thus may cause an environmental problem. Nitrate and pathogens in ground water impact human and animal health, and leaching salts may cause underlying groundwater to be unsuitable for human consumption (U.S.EPA, 1998).

The cited case studies in California, Delaware, and Maryland are examples of nationwide problems of subsurface water and groundwater contamination by confined animal operations and related agriculture, including others in the Midwest. They underscore the importance of managing animal feeding operations to minimize impacts on water quality and public health. The effectiveness of practices to control contaminant losses from animal waste storage facilities and farmlands treated with animal manure depends, among other factors, on the type of contaminants and their likely pathways in the subsurface and ground water. Considerable scientific advances have been achieved in testing, measuring, and modeling the behavior and fate and transport of pollutants in the environment in general, and in the subsurface in particular. However, research is needed to further develop scientifically sound methods for assessing and managing the impact of CAFOs on ground water. With the adoption of the Watershed Protection approach (WPA) as a strategy for

effectively protecting and restoring aquatic ecosystems and protecting human health (USEPA, 1995), risk-based approaches for CAFOs are needed to better integrate environmental and socioeconomic factors in the context of watershed management.

5.3.2 Pollutants, Sources, Transport, and Fate

Animal manure contains nutrients, particularly N and P, dissolved mineral salts, toxic metals, microorganisms, and antibiotics. Among these constituents, however, nitrates, ammonia, and potentially pathogenic organisms are the most common groundwater pollutants. They negatively impact human and ecological health.

Efficacy of risk-based management of animal waste and manure-based agriculture requires understanding the behavior of the pollutants in soil and the processes responsible for their transport through the soil profile to ground water and surface waters. Figure 5.1 depicts potential pathways for movement of a pollutant once introduced into soil. Areas with high soil permeability and shallow water tables are generally most vulnerable to groundwater contamination by pollutants. Percolating water and lagoon leachate may transport pollutants through the soil profile to ground water. Interflow (e.g., subsurface runoff and artificial drainage) and ground water may deliver pollutants to surface waters through hydraulic connections. Not all pollutants are susceptible to transport by leaching, because they are adsorbed onto soil particles, fixed and/or transformed into organic forms by soil microbes. Mobility and persistence of pollutants are controlled by physicochemical characteristics of the pollutant and the soil-aquifer system.

Processes responsible for transport and fate of major CAFO related groundwater pollutants are discussed in the following sections in more detail only for nitrogen compounds, phosphorus, and pathogens.

5.3.2.1 Nitrogen

Animal waste contains nitrogen in organic and inorganic forms, the latter of which is biologically available to microorganisms and plants. Inorganic ammonia exists in two forms in natural waters: ammonium ion (NH_4^+) and un-ionized ammonia (NH_3). The un-ionized form is toxic to fish in low concentrations. Whereas nitrate is water soluble and moves freely through most soils, ammonia compounds are much less mobile and thus, much less susceptible to leaching in soils. Figure 5.2 depicts processes primarily responsible for transformation of nitrogen compounds in sediments at the bottom of lagoons (collection ponds) or in a topsoil layer treated with animal manure.

5.3.2.2 Ammonia

Ammonia due to direct loadings and to the decomposition of organic nitrogen (ammonification) is oxidized under aerobic conditions in the process of nitrification to form nitrite (NO_2^-) and then nitrate (NO_3^-). This process consumes oxygen and, thus, may seriously deplete the water body's oxygen levels. Ammonia nitrogen may be lost by volatilization of un-ionized ammonia (NH_3) from soil or a water body's surface. Ammonium (NH_4^+) is biologically available for plant uptake.

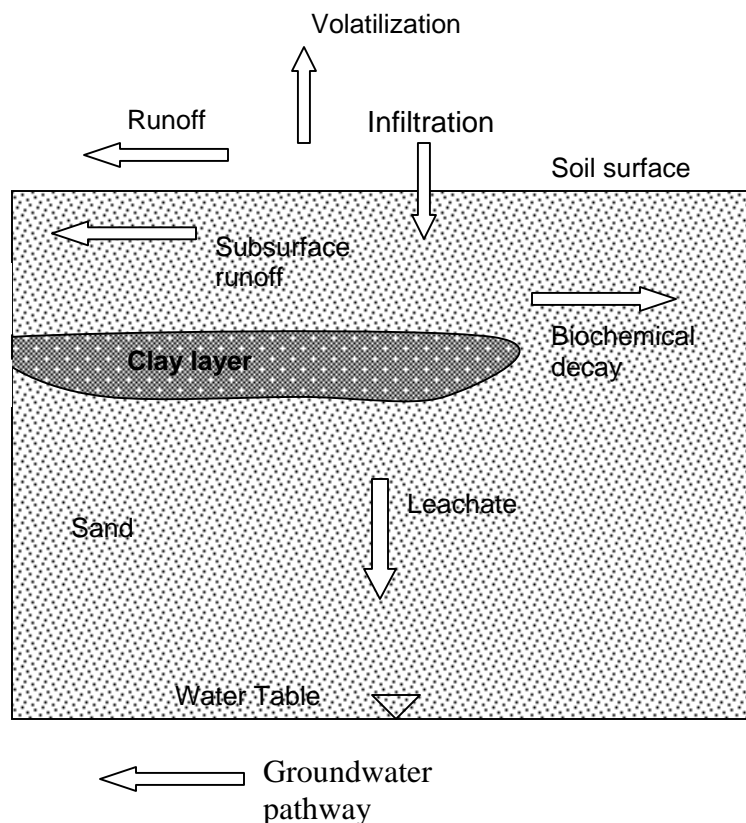

Figure 5.1. Transport pathways of pollutants derived from animal waste.

5.3.2.3 Nitrate

Nitrate is water-soluble and moves freely through most soils. It is produced by nitrification of NH_4^+ . Nitrate is biologically available and may be taken up by plants. Under anaerobic conditions, nitrate may be reduced to N_2 by denitrification, a primary process in reducing nitrate in ground water (Crandall, 1999). Denitrification occurs in the absence of dissolved oxygen and in the presence of chemically reduced compounds such as organic carbon or iron sulfide minerals such as pyrite (FeS_2). This process is usually mediated by bacteria, which derive energy from the reaction.

Riparian buffers and wetlands decrease nitrate concentrations and therefore are considered natural sink areas for NO_3^- . It is important to consider both groundwater hydrology as well as biological processes, such as plant uptake, nitrogen fixation, and denitrification, in understanding reductions of nitrogen in riparian buffers. In these areas, denitrification and dilution by discharging ground waters are primary mechanisms for the reduction of nitrate concentrations (Clausen et al., 2000). Whereas the width of vegetated riparian strips is the current focus for mitigating NO_3^- contamination, more attention should be directed to the depth and location of organic-rich riparian sediments, and the groundwater flow path in influencing the ability of riparian zones to remove nitrate (Devito et al., 2000; Mengis et al., 1999).

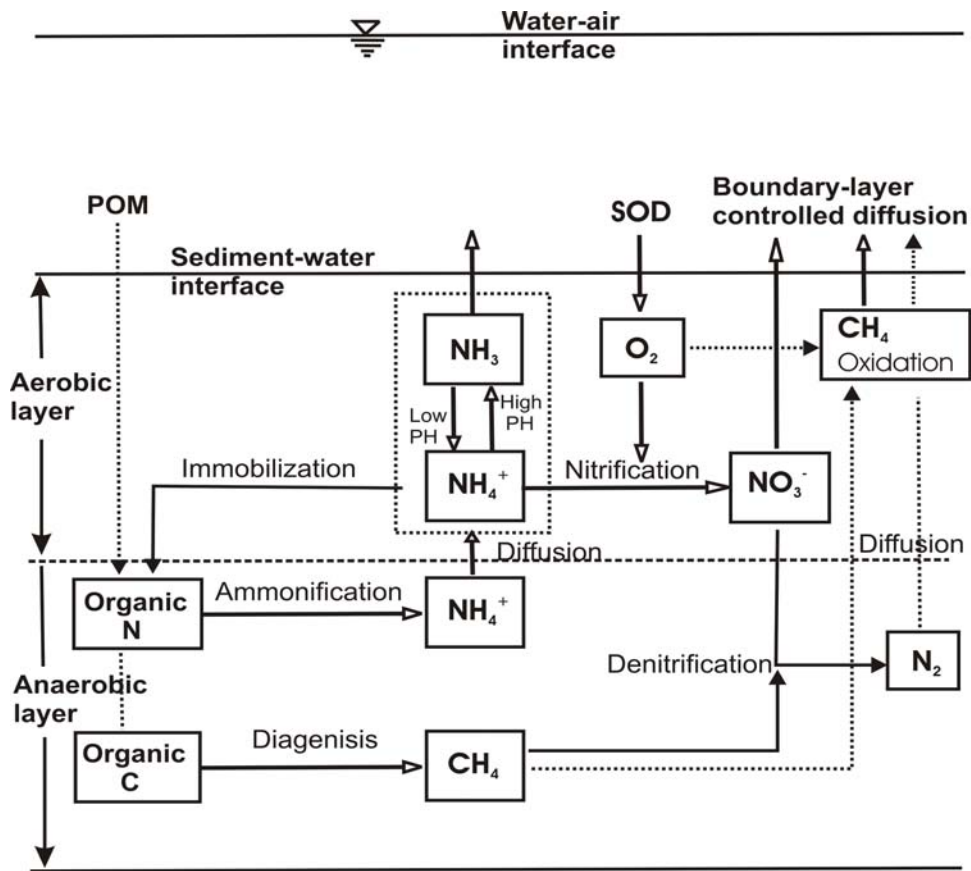

Figure 5.2. Nitrogen-carbon cycling in soil/sediment derived from animal waste.

Nitrate transport in ground water flowing through aquifer sediments occurs by advection (bulk motion with seepage flow) and dispersion produced by molecular diffusion and mechanical mixing through interstitial pore space (Figure 5.3). There is evidence that denitrification may occur at depth in aquifers when ground waters flow through reducing sediments (reduced iron minerals such as iron sulfide and organic-rich sediments) under anaerobic conditions (Korom, 1992, Böhlke and Denver, 1995). This process has the potential of reducing NO_3^- concentrations in ground water significantly (Hantush and Mariño, 2001).

5.3.2.4 Phosphorus

Organic and inorganic phosphorus exist in animal waste. Inorganic phosphate readily adsorbs to soil particles, limiting its potential for leaching through the soil profile. Inorganic phosphate is the plant-available form and is a major contributor to eutrophication of water bodies by stimulating algal growth. Organic phosphorus compounds may be soluble and as such are subject to leaching in the soil (Sweeten, 1991). Most organic forms of phosphorus are readily metabolized to inorganic phosphorus in the soil. Phosphorus adsorption-desorption reactions in the soil govern release of available P (Siddique et al., 2000). Phosphorus binds to clays, organic matter, and Fe and Al oxides, which comprise the most easily eroded soil components (Sims et al., 2000). As such, erosion of soil may generate a P-enriched sediment that may have effects on depositional areas of water bodies. With continual applications of animal waste containing P, the soil may become saturated with P and the potential for both erosion and leaching losses increases. Sandy soils are especially vulnerable to over-fertilization with mineral or organic fertilizers (Sims et al., 1998). Sandy soils lack the fine-grained materials that adsorb P and hold it in the soil. Macropore flow of water may also be a mechanism for the transport of P into groundwater and tile drains (Øygarden et al., 1997).

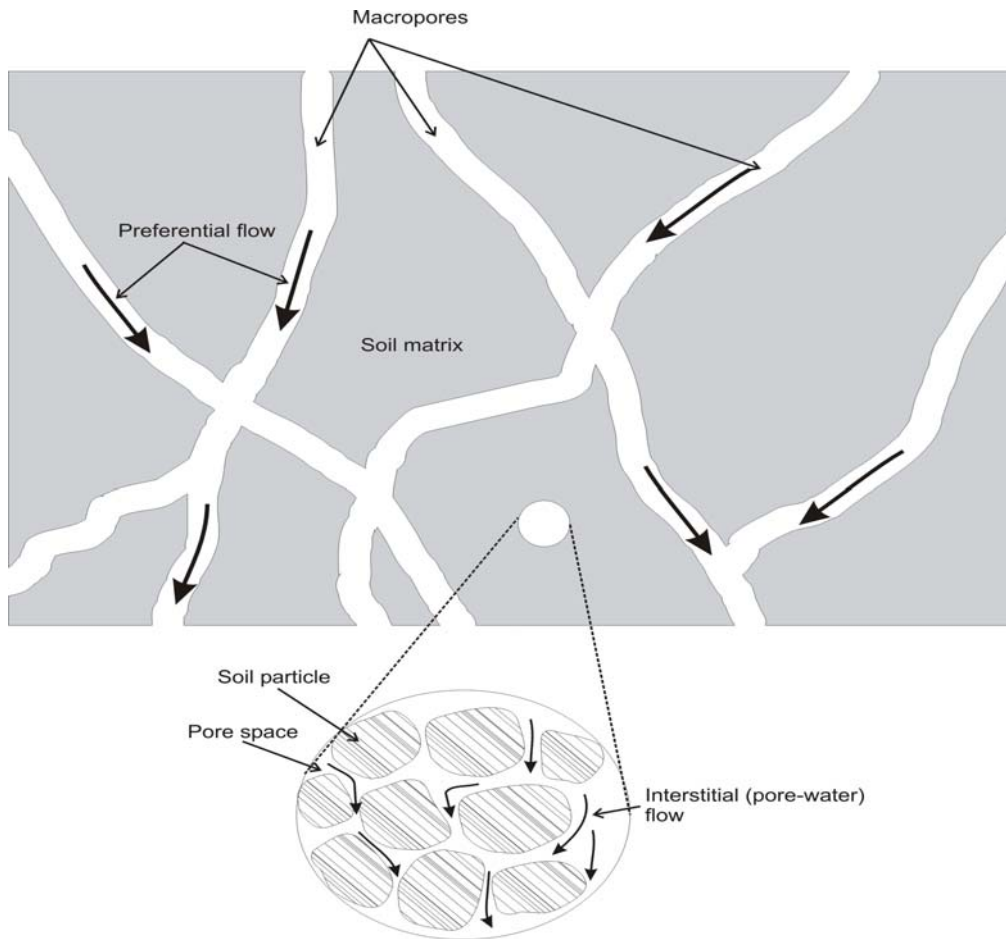

Figure 5.3. Diagrammatic illustration of preferential flow through macropores and interstitial (pore-water) flow in the soil matrix.

Dissolved inorganic P may be higher in concentration than eutrophication thresholds in surface waters (Ryden et al., 1973, Sims et al., 1998). Managing phosphorus to limit its entry into water bodies is a key need in controlling pollution from CAFOs.

5.3.2.5 Pathogens

The fate and transport of microbes in soil and groundwater are controlled by physicochemical characteristics of the microbe and the soil/aquifer media (Robertson and Edberg, 1977). Key characteristics of the microbe include size, inactivation (die-off) rate, and surface electrostatic properties, shape, and specific gravity. Key properties of the soil/aquifer system include soil texture, grain size, porosity, particulate organic carbon content, temperature, pH, and other chemical characteristics of water and mineral composition. Primary mechanisms for the transport and fate of pathogens include advection, retardation, and mortality. Percolating water provides the advective mechanism for downward movement of microbes through soil profiles. In saturated flow, water by-passes the filtering effect of the soil matrix and transports microorganisms long distances in the soil macropores (Mawdsley et al., 1995). Retardation occurs primarily by natural filtering (entrapment) and adsorption, mainly of hydrophobic nature (Carne et al., 1980). Retardation effects provide time for inactivation to eliminate the organisms. Entrapment of microbes by the soil may lead to mortality that is influenced by environmental factors, such as dryness, pH,

predator soil microorganisms, lack of percolation water, and organic matter content (Rosen, 2000). Viruses are generally more resistant to inactivation and more mobile than bacteria in ground water. Typical half-lives for microbes in ground water range from a few hours to a few weeks (Robertson and Edberg, 1977). Greater microbial movement occurs in coarser soils with larger pore sizes. Smaller pore size affects filtration of bacteria and protozoa more than smaller viruses. Macropores transport microbes to greater depths in undisturbed soils due to water flow bypassing the main filtering effect of the soil as it flows through the macropores (Thomas and Phillips, 1979, Mawdsley et al., 1995, McCoy and Hagedorn, 1979). Irrigation soon after manure application may move fecal coliforms into tile-drains fairly rapidly (Geohring et al., 1999). Adsorption of microbes occurs primarily onto charged surfaces of clay and organic matter. Fine-grained soil and aquifer materials have larger surface areas available for adsorption. Due to hydrophobic partitioning of microbes to organic matter, an aquifer that has relatively high organic carbon content will tend to retard the migration of microbes more than an aquifer with little or no organic carbon. The greatest potential movement of pathogens to ground water occurs through sandy soil compared to clay soil. Microbes move faster in fractured rocks than in granular aquifers, primarily for two reasons. First, the former conduct flow much more rapidly, thus providing greater advection of microbes than the latter. Secondly, fractured rocks generally have much less mineral surface area than granular aquifers, thus exhibiting less adsorptive retardation of microbes.

Retardation of microbes in soils depends on several factors, such as size, shape, surface electrostatic properties, and specific gravity. Hydrophobic adsorption on to soil organic matter is a much more important retardation mechanism than soil filtration for most microbes in ground water. Increasing organic carbon content decreases virus mobility and effectively immobilizes virus migration in aquifers. Because of the size and surface electric properties, viruses are much more mobile in ground water than *Cryptosporidium* and *Giardia*. Larger microbes, such as bacteria and protozoa, are more susceptible to filtering in soil than viruses. Hydrophobicity and cell size affect microbial association with soil particles and hence their survival and transport in soil.

Spatial variation of soil pH and temperature influence the transport and survival of microorganisms in soils. Adsorption and movement of viruses and bacteria appear to be strongly correlated with increase in soil pH. Soil temperature affects adsorption and survival of microorganisms through soil. In general, low temperature favors survival of microbes (Hurst et al., 1980).

Plant roots tend to increase the translocation of bacteria through soil (Kemp et al., 1992, Mawdsley et al., 1995). Infiltrating water may accelerate movement through root channels. There is evidence that earthworms enhance transport of bacteria in soils following slurry application (Opperman et al., 1987).

5.3.3 Risk Management

Risk management implies weighing the risks to human health and the environment, against costs associated with potential alternative management strategies (Rosen, 2000). Design of animal waste and wastewater storage facilities, and management of manure-based agriculture require the comparison of associated costs with the risk of groundwater pollution. Measures for groundwater protection may focus on: 1) minimizing seepage of manure and wastewater to ground water; and 2) implementing nutrient best management by adopting specific farming practices.

5.3.4 Storage Facilities

Manure and wastewater may be stored in earthen impoundments (e.g., lagoons) or underground storage tanks. The use of lined lagoons or closed storage tanks depends on site-specific conditions (soil,

hydrogeology, climate, and geography), available material, and economics. Leaching of pathogens or soluble pollutants such as nitrate from earthen impoundments and leaky underground storage tanks constitutes a major concern when the potential of groundwater pollution is a primary component of the risk-management criteria. In general CAFOs should be located away from areas with high leaching potential, such as highly permeable underlying bedrock and soil (EPA, 2001). For example, lagoons should be located on soils with low to moderate permeability or on soils that may form a seal through sedimentation and biological action. Most CAFO facilities are either paved or highly compacted, and therefore relatively impervious. Seepage from storage facilities may be minimized by soil compaction, self-sealing, liners, and soil amendment (EPA, 2001). The associated cost varies across the different measures, with concrete and synthetic liners being the most expensive. A risk-based management approach would require comparing associated costs with the possibility of failure of alternative measures designed to prevent the potential for groundwater pollution at an acceptable level of risk.

Self-sealing with manure solids or by fine organic matter and bacterial cells reduces infiltration and therefore minimizes the leaching potential after a finite period of facility operation (say, a few months). Although this is the least expensive alternative, early in the life of a facility significant leaching may occur leading to increased potential for groundwater contamination by pollutants such as nitrate and pathogens. Relying on self-sealing alone may not be an effective means for reducing leaching potential (Frarey et al., 1994; U.S.EPA, 1998). Sealing is generally effective for cattle manure and in fine-textured soils (high clay content). Liners made of concrete, synthetic material, or compacted clay may be needed under some site conditions (EPA, 2001): 1) a shallow water table; 2) an underlying aquifer used for a domestic water supply or of ecological significance; and 3) highly permeable underlying soil or bedrock (e.g., coarse sand, fractured limestone) (Figure 5.4-5.5). Clay-lined lagoons have the potential to leak and impact groundwater quality (EPA, 1998; Ritter and Chirnside, 1990), since they are susceptible to burrowing worms and cracking as they age. Appropriately sealed below ground storage tanks are effective means for preventing seepage of manure to ground water in sites with porous soils and fractured bedrock.

From a watershed prospective, any practice that reduces infiltration or seepage will reduce the capacity of the soil profile to transmit pathogens and soluble pollutants, specifically nitrate, to ground water. The optimal choice will ultimately depend on incurred costs and acceptable risk level of potential groundwater and surface-water pollution.

5.3.5 Farming Practices

Manure is a beneficial soil amendment and contains nutrients valuable for plants; when managed appropriately this may reduce costs associated with the use of commercial fertilizers. However, stockpiling and land application of manure in excess of crop requirements carry environmental risks, such as surface water and groundwater loading of nutrients (Schepers and Francis, 1998). Composted manure improves soil properties while providing plant nutrients and may save energy by replacing commercial fertilizers; e.g., 3 billion Btu/acre (Deluca and Deluca, 1997). Compost has an advantage over raw manure as it destroys plant and human pathogens and insect larvae.

Ideal management of manure requires: 1) application of manure at agronomic rates; and 2) site management (e.g., tillage, crop residue management, grazing management), which minimize nutrient losses from topsoil and surface water and groundwater loading of pathogens by runoff and leaching. Sound application rates and timing of application reduces losses of nitrogen, especially nitrate, and phosphorus in subsurface drainage water (Randall et. al., 2000). Manure should be applied at agronomic rates, frequently



Photo courtesy of USDA NRCS.

Figure 5.4. Concrete manure storage tank. Structures of this type will prevent leakage of waste into groundwater.

throughout the growing season, rather than a few concentrated applications. This will prevent rapid leaching in coarse-textured soils (high in sand) and avoid runoff in fine-textured soils (high in clay). Although application of manure at agronomic rates reduces nitrogen transport to ground water, it does not eliminate the risk for groundwater pollution entirely (EPA, 1998). This is because: 1) nitrate is highly mobile and may move below the root zone before being taken up by plants; 2) uncontrollable recharge events, such as rain, may cause leaching of excess nitrogen below the root zone; 3) much of the nitrogen applied is in organic form; however, when mineralized it is released in an inorganic form (ammonium and nitrate) potentially available for transport to ground water (not as much if in the ammonium form, due to adsorption to soil particles); and 4) nitrogen transport is affected by manure application method (e.g., drip irrigation, spray irrigation, knifing, etc.). Potential transport of nitrate to ground water is greater in areas of high soil permeability and shallow water tables; thus, application in these areas should be managed appropriately. A great potential exists for nitrogen mineralization when feedlots are abandoned, leading to leaching of nitrate through the soil profile to ground water (Mielke and Ellis, 1976). Planting corn and alfalfa in abandoned feedlots may remove nitrogen as it mineralizes.



Photo courtesy of USDA NRCS.

Figure 5.5. A new lagoon with a synthetic geotextile liner to prevent seepage into groundwater.

Groundwaters in areas of sandy soil, limestone formations, or sinkholes are particularly vulnerable to pathogen transport (EPA, 1998). Pathogens are also prone to movement via macropores. Tillage in the zone above tiles disrupts macropores and reduces transport of nutrients and pathogens to tile drains and ground water (Shiptalo and Gibbs, 2000). Shearing of the macropores by tillage appears to limit microbial transport (Dean and Foran, 1992; and Randall et al., 2000). No-till soils have higher earthworm populations, thus more earth-formed macropores (Shiptalo and Gibbs, 2000). Application of manure immediately after irrigation and in the vicinity of tile drains should be avoided to prevent movement of pathogens (e.g., fecal coliforms) to drainage effluent (Geohring et al., 1999). Factors that need to be considered for minimizing the loss of microorganisms in runoff and leaching include (USDA, 2000): 1) climate conditions; 2) waste application techniques and timing; 3) location of applications.

There is a potential for phosphorus to leach into ground water through sandy soils with high phosphorus content. Land-applied phosphorus is much less mobile than nitrogen because the mineralized (inorganic phosphate) form is highly adsorbed onto soil particles. High application rates may result in the accumulation of particulate and soluble forms of P that are potentially available for transport through earthworm burrows and other preferential paths to tile drains and the water table.

From a watershed perspective, measures to reduce movement of nutrients and pathogens through the soil matrix and flow-through macropores (preferential flow) would reduce the potential for groundwater pollution. This would require sound farm practices focused on application rates and timing of manure application based on local climatic conditions and location. Different levels of management may be

appropriate for different areas of a watershed. Larger areas where freely draining soils, high manure and fertilizer N applications are made should occur on the upper boundaries of the watershed. Areas most susceptible to P loss should not be located near the stream channel and should constitute a much smaller fraction of the watershed (Sharpley et al., 1998).

5.3.6 Natural Filters

The most common practices to reduce runoff, leaching, and drainage from CAFOs include: 1) terraces; 2) cover crops; 3) filter strips and riparian buffers; and 4) wetlands.

Terraces reduce runoff and soil erosion. Measures to stop erosion may significantly decrease particulate and dissolved forms of P loss (Withers and Jarvis, 1998). Cover crops use available nutrients in soil, especially nitrogen, thus preventing or decreasing leaching. However, terraces depending on soil type may promote infiltration into ground water. Figure 5.6 shows a terrace built between two fields to limit the erosion of soil on sloping land.



Photo courtesy of USDA NRCS.

Figure 5.6. Terraced fields to limit the erosion of soil on sloping land.

Filter strips and riparian buffers include grass, shrubs, and trees along the riparian interface with cropland and pasture. They are designed to intercept undesirable contaminants (e.g., sediments, manure, pathogens, fertilizers, pesticides, etc.) from surface water and subsurface flows (EPA, 2000). Filter strips/riparian buffers may be effective treatment of overland and shallow subsurface flows for nitrogen and particulate phosphorus removal. Managing riparian zones with the intent of mitigating NO_3^- contamination

needs to be refocused on characteristics more important than specific buffer width, such as depth of riparian sediments, groundwater hydrology in that vicinity, and the location of organic-rich sediments (Devito et al., 2000). Denitrification and dilution processes are primarily responsible for the removal or reduction of nitrate in groundwaters discharging through riparian sediments (Clausen et al., 2000). Plant uptake may reduce nitrate concentrations in riparian buffers.

Wetlands occur when the water table intercepts the land surface near streams. Nitrate is primarily reduced by denitrification and dilution by upwelling ground water in the wetland area. Constructed wetlands are low maintenance systems that may reduce nitrate from agricultural drainage in artificially drained watersheds (Kovacic et al., 2000). Anaerobic conditions in the presence of organic matter promotes denitrification of NO_3^- , which may be further reduced by plant uptake and mixing with nitrate-free discharging ground waters.

The role of riparian buffer zones and constructed wetlands as nutrient sinks has implications on management of CAFOs in watersheds. Given acceptable levels of risk, the management of animal waste and manure-based agriculture at the watershed scale may be significantly impacted by considering the potential for removal of nutrients naturally, especially nitrate from subsurface drainage in wetlands and riparian buffer zones.

6 Air Transport and Deposition

Water and air quality issues are related. There has been a lack of CAFO-related research to deal with both water and air quality issues in a holistic (systems) approach while maintaining high standards of confined livestock productivity, animal health, and production cost efficiency (Sweeten 2001; Sweeten et al., 2000). Concentrated animal feeding operations may consist of open lots or confinement buildings, manure/wastewater storage or treatment systems, land application areas, and facilities to handle animal mortalities. CAFOs may generate many types of wastes, which include manure (feces and urine), waste feed, water, bedding dust, and waste water. Air emissions originate from the decomposition of these different types of wastes from the point of generation through the management and treatment of these wastes on the site. The rate at which the air emissions are generated will vary as a result of several operational variables (housing type, animal species, and waste management system), and weather conditions (humidity, temperature, wind direction and the time of a wind release). The air emission burden on the atmosphere is the product of the contaminant concentration and the airflow rate (USEPA 2001).

6.1 Current Air Quality Issues Associated with Agriculture

Six major pollutants have been identified and attributed to air emissions from animal housing areas, animal waste treatment and storage areas, and application of animal waste to the land. An overview of these pollutants follows.

6.1.1 Ammonia

Ammonia is an inorganic nitrogen compound that is easily emitted to the atmosphere from animal wastes (USEPA 2001). Ammonia is one of the fixed gases of aerobic and anaerobic decomposition of organic wastes. The major source of ammonia in animal manure is urea from urine or uric acid (in poultry). During microbial breakdown of fecal material in confinement buildings, on feedlot surfaces, in stockpiles, and in lagoons or runoff retention ponds, additional ammonia and amines are produced. Ammonia evolution rates are a function of time, temperature, pH of the manure surface, and level of biological activity. Ammonia volatilization is probably the most important pathway for on-site loss of nitrogen in animal manure to air and water resources. When ammonia is present as part of an aqueous solution, it reacts with acid to rapidly form the ammonium ion, with little release of ammonia to the atmosphere. Most animal manures, feedlot surfaces and lagoons would typically be a non-acidic environment with a pH greater than 7.0, where a rapid loss of ammonia to the atmosphere will occur. Total nitrogen losses as ammonia may exceed 50% (Sweeten et al., 2000; USEPA 2001).

Anaerobic lagoon and waste storage ponds are main components of the waste management systems at many CAFO sites. These systems depend on microorganisms to mineralize organic nitrogen to ammonium and ammonia. The ammonia will continually volatilize from the surface of the lagoon and pond. As much as 70%-80% of the nitrogen in a lagoon changes from liquid to gas, which will escape into the atmosphere in a process known as ammonia volatilization. Depending on the amount of carbon-rich bedding used, the more carbon, the lower the ammonia emissions. Bedding is used when the manure is not liquefied, and the bedding with absorbed manure and urine is stored in a solid form. The bedding creates a porous mixture wherein free air space provides conditions suitable for aerobic microbes to flourish. The decomposition of solid manure by aerobic bacteria begins a heating process known as composting. This decomposition process produces heat, water vapor, carbon dioxide, and ammonia. Only ammonia is odorous, and its emissions are low if the farmers use enough carbon-rich bedding to keep wet spots in the

beds covered and maintain a high carbon/nitrogen ratio in the manure-bedding mixture. The gaseous ammonia returns to earth, precipitated from the atmosphere by rain or trapped by trees, grass, or water bodies, in a process known as atmospheric deposition. For example, a typical five-acre hog waste lagoon releases 15-30 tons of ammonia into the air annually. Approximately half of the ammonia rises as a gas and generally falls to forests, fields, or open water within 50 miles, either in rain or fog. The rest is transformed into dry particles that travel up to 250 miles. Ammonia is the most potent form of nitrogen that triggers algae blooms and causes fish kills in coastal waters. The North Carolina Division of Water Quality estimates that hog factories constitute the largest source of airborne ammonia in North Carolina, more than cattle, chickens, and turkeys combined. In 1995, Hans Paerl, a marine ecologist from the University of North Carolina, reported that airborne ammonia had risen 25% each year since 1991 in Morehead City, 90 miles downwind of the hog belt (Halverson, 2000).

At concentrations found in the livestock facilities (< 100 ppm), the primary impact of aerial ammonia is as an irritant of the eye and respiratory membranes. The impact of aerial ammonia as a chronic stressor may affect the course of infectious disease and directly influence the growth of young animals (Sweeten et al., 2000; Merchant et al., 2002). Ammonia is recognized as a human toxin. Because ammonia is water-soluble, it is rapidly absorbed in the human upper airways, which results in damaging the upper airway epithelium. Moderate concentrations of ammonia (50-150 ppm) may lead to severe cough and mucous production. For example, exposure to 100 ppm for 30-second periods leads to nasal irritation, and nasal airway resistance increases. Lower concentrations (7 ppm) of ammonia adsorbed to respirable particles may reach the alveoli (Merchant et al., 2002). Higher concentrations of ammonia (> 150 ppm) may cause scarring of the upper and lower airways. A consequence of these inflammatory responses is reactive airway dysfunction syndrome and associated persistent airway hyper-responsiveness. At much higher ammonia concentrations, the ammonia may pass the upper airways to cause lower lung inflammation and pulmonary edema. Chemical burns to the skin and eyes may also occur. Massive exposure (in the range of 500 ppm) to ammonia may be fatal.

6.1.2 Nitrous Oxide

Nitrous oxide is one of the most potent agricultural greenhouse gases that contribute to global climate change. Nitrous oxide is produced in the nitrogen cycle during nitrification and denitrification of the organic nitrogen in livestock manure and urine. The emission of nitrous oxide is a function of the nitrogen content of the manure, the length of time the manure is stored, and the specific type of manure management system used. Nitrous oxide is released from natural processes in the soil, from nitrogen fertilizer, fossil fuel combustion, animal and human wastes, water bodies, biomass burning, and land clearing. The amount of nitrous oxide emitted tends to be small from manure because pH-dependent environmental conditions are often not suitable for nitrification to occur. Nitrous oxide has over 200 times the warming effect of carbon dioxide and lasts 150 years in the atmosphere. It is the least prevalent of the agricultural gases that contribute to the greenhouse effect, contributing only about 3% of the global warming burden (USEPA 2001; Agriculture and Agri-Food Canada 1998; Halverson 2000).

6.1.3 Methane

Methane is colorless, odorless, lighter than air, and is another one of the highly potent greenhouse gases that contribute to global climate change. Methane has a long residence time in the atmosphere (5-10 years). It is produced during the normal digestive processes of animals and the decomposition of animal manure. When the organic material from livestock manure is placed under anaerobic conditions, large populations of methanogenic bacteria are enriched, producing large quantities of methane. The main factors that influence methane emission from livestock manure are the methane-producing potential of the

waste and the proportion of the manure microbial population able to produce methane. These main factors will depend on how the manure is stored, treated as a liquid, handled as a solid, and the length of time before manure deposition on pastures and rangelands. When livestock manure decomposes aerobically, little or no methane is produced (Merchant et al., 2002; Agriculture and Agri-Food Canada 1998; USEPA 2001).

6.1.4 Carbon dioxide

Carbon dioxide is a naturally occurring, voluminous greenhouse gas and is emitted into and removed from the atmosphere on a continuous basis. Carbon dioxide emissions are produced during microbial degradation of animal manure under aerobic and anaerobic conditions. When animal wastes are stored as liquid waste, an increase occurs in the amount of carbon dioxide produced and emitted compared to dry storage. Carbon dioxide emissions may frequently occur from the combustion of biogas from anaerobic digesters used to recover energy (USEPA 2001; Halverson 2000).

6.1.5 Hydrogen sulfide

Hydrogen sulfide is a potentially lethal gas produced by anaerobic bacterial decomposition of protein and other sulfur containing organic matter. This colorless gas with the distinctive odor of rotten eggs is heavier than air and may accumulate in manure pits, holding tanks, and other low areas in a livestock facility. The production of hydrogen sulfide is dependent on the outside air temperature, the size of the housing and waste management areas, the air retention time in the housing areas, and the daily sulfur intake of the animals. The sources of hydrogen sulfide presenting the greatest hazard in an agricultural setting are liquid manure holding pits that are commonly located under the slatted floors of livestock facilities. Although most of the continuously produced hydrogen sulfide is retained within the liquid of the pit, the gas is rapidly released into the ambient air in small quantities when the waste slurry is agitated to suspend solids prior to being pumped out. While the concentration of hydrogen sulfide found in closed animal facilities (<10 ppm) is not harmful, the release of this gas from the manure slurry agitation may produce concentrations up to ≥ 1000 ppm. Hydrogen sulfide is an irritant gas that produces local inflammation of the moist membranes of the eye and respiratory tract. Respiratory tract symptoms include irritation of the throat and a cough. Exposure to concentrations (> 150 ppm) of hydrogen sulfide may impair the sense of smell, hindering the olfactory detection of high concentrations of the gas. Chronic or acute occupational exposure to hydrogen sulfide concentrations at elevated levels between 100 - 1000 ppm may cause rapid loss of consciousness, shock, acute respiratory distress syndrome (ARDS) or pulmonary edema, coma and death. The primary mode of absorption of hydrogen sulfide is through inhalation. The toxic effects of hydrogen sulfide are based on its property as a chemical asphyxiate. It binds to the mitochondrial enzyme cytochrome oxidase, blocking oxidative phosphorylation and ATP production. This leads to anaerobic metabolism and the development of lactic acidosis (USEPA 2001; Thu 2001; Merchant et al., 2002). Few states, with the exception being Minnesota, have hydrogen sulfide standards. Other states have different standards (Sweeten et al., 2000; USEPA 2001; Halverson 2000; Yale Center for Environmental Law and Policy).

6.1.6 Criteria Air Pollutants

Criteria air pollutants include volatile organic compounds (VOCs), and particulate matter (USEPA 2001). Many VOCs are formed when the livestock waste is in a dynamic state, fluctuating between aerobic and anaerobic conditions. VOCs are formed when the hydrolytic and acetogenic bacteria ferment the organic matter in the waste. Some of the volatile organic compounds that emanate from CAFO facilities include acetaldehyde, acetone, acetophenon, acrolein, benzaldehyde, benzene, bis(2-ethylhexyl) phthalate, 2-butanone, carbon disulfide, carbonyl sulfide, chloroform, crotonaldehyde, ethyl acetate, formaldehyde,

formic acid, hexane, isobutyl alcohol, methanol, 2-methoxyethanol, naphthalene, phenol, pyridine, tetrachloroethylene, toluene, triethylamine, and xylene. Other air pollutants associated with CAFO facilities include volatile fatty acids (VFAs) and odor compounds. The incomplete anaerobic degradation of carbohydrate, protein, and lipid components in livestock waste results in the formation of short-chain VFAs (Varel, 2001). The VFAs produced include butyric, isobutyric, caproic, isocaproic, valeric, isovaleric, propionic, phenylpropionic, lauric, acetic and phenylacetic acids (Merchant et al., 2002). The odor compounds emanating from CAFOs include the phenolic compounds, such as phenol, ethyl phenol, and cresols, and the nitrogen-containing compounds, such as ammonia, amines, pyridines, indole, skatole, trimethylamine, trimethyl pyrazine, and tetramethyl pyrazine (Merchant et al., 2002).

Particulate matter is identified as either PM-10 standard (less than 10 μm in diameter) and PM-2.5 standard (less than 2.5 μm in diameter, referred to as respirable particulate matter). Particulate matter is a consequence of interactions of animals with their environment. Particulate matter is composed of animal bedding, fecal matter, litter, feed materials, animal byproducts such as skin cells or feathers, and the products of microbial action on feces and feed, bacteria, fungi, viruses, metals, and hormones. Components of feed include plant proteins, starches, and carbohydrates, feed additives such as vitamins, minerals, amino acids and other supplements, and antibiotics (Merchant et al., 2002).

6.2 Generation of Air Emissions Resulting from Operational Variables

6.2.1 Air Emissions from Land Application Activities

The amount of nitrogen released into the environment from the application of animal waste depends on the rate and method by which it is applied, the quantity of material applied, and site-specific factors (such as air temperature, wind speed, and soil pH). The application of animal waste from CAFOs on cropland generates air emissions. The emissions are the result of volatilization of ammonia immediately after the material is applied to the land. Additional emissions of nitrous oxide are released from farmlands when nitrogen is applied to the soil and at the same time the soil is undergoing the process of nitrification and denitrification. Loss of nitrous oxide through denitrification depends on the oxygen levels of the soil to which the manure is being applied. Low oxygen levels (as a result of wet, compacted, or warm soil) increase the amount of nitrate-nitrogen that is released into the air as nitrogen gas or nitrous oxide. For example, research performed by Sharpe, et. al. (1977), compared losses of ammonia and nitrous oxide from sprinkler irrigation of swine effluent. The study concluded that the ammonia emissions made the larger contribution to airborne nitrogen losses (U.S. EPA, 2001). The analysis of air emissions from land application activities mainly focuses on the volatilization of nitrogen as ammonia, because the emission of other compounds is expected to be less significant. Figures 6.1 and 6.2 show potential sources for air emissions of pollutants of concern. High velocity sprinklers may release significant amounts of ammonia and VOCs into the air as well as generating particulates that may move off site if the wind velocity is high. Similarly, application of animal waste from tank trucks may release large amounts of odor compounds and ammonia into the air. Incorporation of the waste into the soil limits losses of odor compounds and ammonia but increases the cost of application.

In addition to the movement of nitrogen in various forms from land-applied waste, bioaerosols or particulates of biological origin may move from land-applied waste. Fragments of cell walls, fungal spores, hyphae, endotoxins, plant cell debris, animal cell debris, and whole cells may all be aerosolized from land-applied wastes. Little information exists with regard to the importance of organic dust movement in the environment.



Photo courtesy of USDA NRCS.

Figure 6.1. High velocity sprinkler, a potential source of airborne contaminants.



Photo courtesy of USDA NRCS.

Figure 6.2. Tank truck applying manure with the potential for aerosol generation.

6.2.2 Odors

CAFOs may affect air quality through emissions of odorous gases (odorants), particulates, and some of the “greenhouse” gases (carbon dioxide, and methane). The odor may affect the health of, and become a nuisance to, nearby residents. The odor created from CAFO sources is the composite of ≥ 170 different gaseous compounds present in livestock manure in trace concentrations above or below a person’s olfactory thresholds. Odor is characterized according to the following characteristics: (a) the strength of the odor (the concentration or intensity); (b) the frequency of the odor (the number of times the odor is detected during a period of time); (c) the duration of the odor (the period in which the odor remains detectable); and (d) the perceived offensiveness, character, or quality of the odor. Some of the general approaches in estimating the strength or intensity of livestock manure odors are: (a) sensory devices (e.g., scentometer, dynamic olfactometers, absorption media, etc.) that involve collecting and presenting odor samples (diluted or undiluted) to trained evaluators under controlled conditions; (b) direct or indirect measurement of concentrations of distinct odorous gases; and (c) electronic “nose” devices, a series of gas sensors combined with pattern recognition software to mimic human olfactory responses. The electronic nose device registers the presence, concentration, or activity of selected odorous gases. Odor frequency and duration are partially governed by climatic conditions, in addition to atmospheric stability, moisture conditions, and wind-direction frequency.

Anaerobic degradation involves the reduction of complex organic compounds to a variety of odorous VFAs by acid-forming bacteria. Methane-forming bacteria convert VFAs to odorless methane and carbon dioxide. If these anaerobic processes are in balance, most odorous compounds are eliminated. However, under certain conditions in manure storage or overloaded anaerobic treatment lagoons, acid-forming and methane-forming processes are not in balance, resulting in an accumulation of VFAs. Also, sulfate-reducing bacteria found in anaerobic environments convert sulfate to hydrogen sulfide and other sulfur-containing compounds. Anaerobic degradation by sulfate-reducing bacteria and an imbalance of acid- and methane-forming bacteria are significant sources of odorous compounds (Midwest Plan Service).

Jacobson et al., evaluated odor and hydrogen sulfide concentration in air from 60 different pig, dairy, beef, and poultry manure storage units on farms. A low correlation was found between hydrogen sulfide and odor concentration for manure storage based on a species comparison and for production systems grouped according to manure management system type (basin, lagoon, and pit) (Zahn et al., 1997, 2001).

6.2.3 Particulate Matter

Particulate matter is solid matter or liquid droplets less than 100 μm in diameter from dust, smoke, fly ash, and condensing fugitive vapors that are carried in the outdoor air. Air quality standards have been developed to protect public health from the potential effects of particulate matter less than 10 microns (PM-10), and particulate matter less than 2.5 microns (PM-2.5) in size (Nebraska Dept. Environ. Qual., 2001). When humans or animals inhale dust, a higher proportion of small particles than large particles will travel deep into the lung and be deposited. In general, finer particulate fractions contain a higher proportion of anthropogenic dust and lower levels of wind blown soil and plant pollens. Because lung problems associated with CAFOs include airway disease, it is important to consider inhalable particulate fraction and PM-10 (Merchant et al., 2002).

Bioaerosols are a major component of the particulate matter from CAFOs. Bioaerosols are simply particles of biological origin that are suspended in the air. Bioaerosols include bacteria, fungi, fungal and bacterial spores, viruses, mammalian cellular fragments, pollens, and aeroallergens, toxins, and particulate waste products. Bacterial products or components exist as bioaerosols and include endotoxins, exotoxins,

peptidoglycans, lipoteichoic acids, and bacterial DNA bearing CpG motifs. Fungal products or components include conidia and microconidia, hyphal fragments, mycotoxins and glucans. Various concentrated animal feeding operations are sources of bioaerosols because of the feed material used, the fecal material produced, and the type of bedding material used (Merchant et al., 2002).

Bioaerosols are a respiratory threat to workers performing waste management activities at concentrated animal feeding operations. Inhalation of pathogenic microorganisms may result in an acute disease, with full-blown infections. For example, acute endotoxin inhalation exposure may result in influenza-type symptoms. Chronic endotoxin exposure has been associated with decreased respirometric values (e.g., hypersensitivity pneumonitis) in workers associated with concentrated animal feeding operations. Several studies describe "Organic Dust Toxic Syndrome," which is a health effect associated with particulate exposure (such as asthma).

Some CAFOs have installed engineering controls, (such as ventilation systems) to lower worker exposure to bioaerosols. These ventilation systems will discharge a relatively high concentration of bioaerosols to the environment, unless air treatment unit processes are also installed. The ventilated aerosols that are not treated may cause an air plume to travel beyond property lines. Several factors will determine the downwind concentration of a CAFO generated bioaerosol, some of which include: (1) the distance to the property line; (2) the wind velocity and direction; (3) the biological half-life; (4) the humidity; and (5) the amount of ultra-violet light present. There were not any studies in the literature that evaluated public health exposure beyond a reasonable distance from a CAFO system.

6.3 SUMMARY

Since the early 1970's, very little consideration has been given to air quality protection with respect to agriculture. This has resulted in very little data existing to determine agriculture's impact and contribution to air quality. Significant issues related to agriculture and air quality were presented and informational gaps were assessed to determine the type and amount of resources needed to address issues related to air quality and agriculture.

Animal and production agriculture may produce emissions of odorous gases such as ammonia, hydrogen sulfide, volatile organic compounds/acids, and particulate matter. Current knowledge does not fully describe or reflect potential air emissions produced from these pollutants.

7 RISK MANAGEMENT OPTIONS FOR CAFO WASTE

Now that the risks associated with the large amounts of animal manure present at CAFOs have been described, this document will now discuss what may be done to mitigate CAFO manure pollution. This section will be divided by strategies that are well known, those requiring some additional research, and those strategies that are new and innovative and require significant additional research to fully implement. Within each section we will describe how the strategies discussed will mitigate each of the stressors identified in this document: nutrients, pathogens, EDCs and antibiotics.

Two well known risk management strategies, discussed in detail below, are land application and composting. Land application is the main means by which animal manure from CAFOs is disposed. This often results in excessive application that results in release of manure stressors into the environment. This makes land application part of the problem. It may also be part of the solution if done properly.

7.1 Land Application

This section summarizes the benefits and risks associated with land application of CAFO waste. Application of animal waste to land presents a complex set of topics for consideration. Animal manure has been applied to soil primarily as a disposal operation since the Roman Empire. Similarly, use of animal manure to enhance soil fertility has been known for about as long, but the underlying reasons were only illuminated within the last 150 years. Manure as a fertility agent has several benefits for agricultural production. The advantages come from the value of animal manure as a fertilizer and soil conditioner (Kellogg et al., 2000; USDA/NRCS 1996,1998; Weidner et al., 1969). The nitrogen and phosphorus content of manure has a real value, when substituted for inorganic chemical fertilizer (Bitzer and Sims, 1988; Edwards and Daniel, 1992). The soil conditioning aspect is important. As soil organic matter increases, soil workability improves leading to lower power requirement for equipment. Water holding and infiltration improve leading to greater drought resistance. Nitrogen, phosphorus, and potassium are recycled into the soil with applied manure, thus maintaining fertility. Major portions of N and P in manure are in organically bound components, which function as slow release nutrient sources. The organic matter component of manure maintains or enhances the soil organic matter fraction. The benefits of manure application to soil are well recognized. For most purposes the smaller farm operations may gain the benefits with relatively minor problems.

The liability comes from the need to have adequate land for disposal/treatment, the cost of application including capital costs, labor and transportation costs and the potential environmental liability, should a nearby water body be contaminated by wastes. The task of balancing the advantages and disadvantages lies in successfully measuring the nutrient content of manure and calculating application rates (Iowa State Univ. 1995; Maguire et al., 2000; USDA 1979; USDA/NRCS 1996,1998; Weidner et al., 1969). Allowances must be made for the available N from manure, losses to atmosphere as NH₃, and potential variation in application. Managing application by N content usually results in over-application of P. Managing by P content under supplies nitrogen leading to a need to add inorganic N. Since there are differences in application equipment for manure or inorganic fertilizer, that portion of costs increases.

Every segment of animal agriculture production has examples of waste load exceeding the absorption capacity of the local environment. As discussed in the beginning of this document, the problem derives from concentration of production facilities into relatively small land areas, with little space available

for waste disposal. Some facilities market the waste as fertilizer material, but the transport distance becomes the limiting economic factor (Bosch and Napit 1992). The key question for consideration in this risk management evaluation is how to properly use land application to reduce the risk to water quality from CAFO manure while still realizing its many tangible benefits. Answering this question requires an examination of how manure is currently used and how it may be used more efficiently.

Numerous documents exist providing guidance to the farm operators on every aspect of application of manure to soil. There are documents produced by the USDA, States, and universities that provide examples of how to calculate the fertilizer value of different wastes. The publications provide models of how to substitute manure for inorganic fertilizer to meet yield goals. The key factor is that every facility presents a unique situation with regard to soil type, waste type, soil conditions, erosion potential, and climate. There are no universal solutions for using CAFO wastes as a fertilizer source. Some general principles do apply however. Application rates should be based on the more restrictive crop phosphorus requirements. Waste application should be timed to provide maximum benefit for crops. Manure should not be spread on land in winter where the ground is frozen. Wherever possible, incorporation should be done within 24 hours of application. Soil management to minimize erosion will help mitigate any runoff problems associated with manure. This section is intended to provide an overview of the practices used in land application, some of the problems attendant with land application, and some management practices to minimize problems. The literature citations provided represent a small fraction of available material concerning the subject.

7.2 Practices Used in Land Application

7.2.1 Application Systems

Transport of manure from the site of production or storage to the fields where it is applied may take many forms. Some are simple load and spread systems. Some are more complex with mixing, shredding, pumping and distribution machinery involved. The type of system used varies with the characteristics of the waste being handled. Different animal production facilities have elected different waste handling modes that are most commonly based in ease of operation and cost. Liquid manure application may take several forms (Dougherty et al., 1998). Tractor drawn or truck mounted tank systems may either broadcast or directly inject liquids (Figure 7.1). Tractor pulled broadcast or injection applicators can be supplied by drag hoses or temporary holding tanks. This option reduces potential soil compaction.

Irrigation application may be flood type, gated channels, or various kinds of sprinkler systems. Sprinkler systems may be manually moved, fed from a central pumping station; fixed installation; or center pivot type with central pumping. Use of irrigation type systems may be limited to larger facilities in some cases simply because irrigation systems need a minimum flow volume to function properly. A major drawback to spray irrigation systems for the application of liquid manure is the loss of $\text{NH}_4\text{-N}$ to the atmosphere as NH_3 . The value of the N is lost and the odor potential is high for sprayer systems. Irrigation may serve two functions, one to supply nutrients and the other to supply water to meet crop needs. In some ways, liquid systems may be more limited than others. Installed irrigation equipment is not easily moved; therefore, the same land is repeatedly treated with manure. Other nearby land potentially suitable for receiving manure may be passed over.

The major animal production sectors use different waste handling systems. Factors involved in the elected choices vary from locale to locale. Available data are limited and apply to large production facilities. Some examples of manure distribution systems are listed in Figure 7.2.



Photo courtesy of USDA NRCS.

Figure 7.1. Tractor drawn liquid manure application after corn harvest.

Means of Manure Disposal

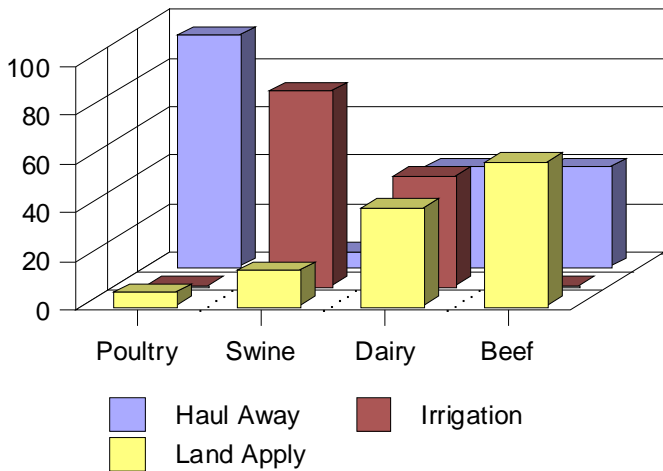

Figure 7.2. Means of manure disposal by animal sector.

7.2.2 Potential Problems Associated with Manure Applications

Although the problems associated with nutrients, pathogens, EDCs, and antibiotics in manure are common to all species of livestock, some additional problems are posed by the way in which the manure is disposed. This is related to the moisture content of the manure, which is related to the species of livestock in question. As shown in Figure 7.2, almost all of the manure generated by poultry facilities is sent off-site

for disposal. Environmental pollution resulting from runoff is probably not a big problem at these facilities as a result of this practice. Nevertheless, myriad problems could result from the off-site transport of poultry waste because the nutrient and pathogen load of the waste will be out of the direct control of the originating facility.

Over-enrichment with N and P may occur when liquid waste is sprayed on land as is done at swine CAFOs. Air pollution may result from volatilization of NH_3 when downwind transport occurs as a result of spray irrigation using liquid waste and wastewater. Runoff of oxygen demanding substances, nutrients, and pathogenic organisms to water bodies may accelerate eutrophication of receiving water and spread pathogenic microorganisms throughout the watershed. (Baxter-Potter and Gilliland, 1988; Culley and Phillips, 1982; Doran and Linn, 1979; Doran et al., 1981; Edwards and Daniel, 1992; Gagliardi and Kerns, 2000, Giddens and Barnett, 1980; Gilley and Eghball, 1998; Jawson et al., 1982; Larsen-Royce et al., 1994; Pell 1997; Smith et al., 1985; Wolf et al., 1988).

Transport of nutrients and microorganisms to groundwater may also occur from both the application of liquid waste and the spreading of solid manure on land. Another avenue for nutrient losses exists in the leaching of soluble nutrients either to groundwater or drainage tile (Entry and Farmer, 2001; Evans et al., 1984; Gangbazo et al., 1995; Simpson 1990). N applied in manure as NH_4^+ will exchange on to soil cation exchange sites. This form of N does not readily move, but may be nitrified to NO_2^- and NO_3^- (Eghball 2000) that are freely mobile in soil water. Subsequently, denitrification may reduce the $\text{NO}_3^-/\text{NO}_2^-$ to N_2O or N_2 (Rochette et al., 2000; Stevens et al., 2001)

Even the subsurface injection of solid manure may contaminate water sources as the result of channel flow through the vadose zone. The channels may take the form of worm burrows, root channels, or animal burrows. P usually rapidly converts to insoluble forms, but with high application rates and rainfall, P will move as soluble P. Water-soluble organic N and P may also move into groundwater or drainage tile. Movement of NO_3^- into groundwater may increase NO_3^- levels above the federal standards of 10 mg/L. Too much NO_3^- in water presents a risk to very young children by causing methemoglobinemia (already been said). Loss of N and P to drainage tile primarily represents loss of the fertilizer value of the applied manure. It also increases the potential for eutrophication of receiving waters.

The bacterial load of animal waste either applied to the soil surface or injected below ground may enter the channels existing in the soil and migrate into drain tile. If water flow is relatively large, the water may transport organisms including pathogenic organisms to receiving streams, lakes, or ponds. This pathway is easily overlooked as it is assumed that water entering drain tile has been filtered through the overlying soil. Studies of the movement of bacteria through the soil profile are recent. Entry and Farmer, 2001 examined coliform and nutrient movement in a sand aquifer below fields irrigated with river water. Smith et al., (1985) also showed that *E. coli* could move through soil most easily in undisturbed soil columns. Tilled soil was more effective in retarding the movement of the organisms. Gagliardi and Kerns, (2000) reported that *E. coli* O157:H7 could move through agricultural soils under different management practices. Patni et al., (1984) studied the bacterial quality of water in tile drains under manured and fertilized cropland. Their results showed that bacteria could move easily through the soil profile. Shipitalo and Gibbs, (2000) showed that injected manure could move to tile drains within minutes of application through worm burrows. The width of the transmission zone was about one meter at the soil surface.

Because movement of microorganisms through soil profiles has been observed, it is also likely that EDCs and antibiotics may move with the water flowing through the same channels that allow passage of the microorganisms.

7.2.3 Soil Management Practices to Reduce Problems

Control of potential pollution from land-applied manure requires attention to good soil management practices (Cook et al., 1996; Dillaha et al., 1986; Young et al., 1980). Soil management to reduce erosion losses will reduce potential manure runoff losses of oxygen demanding compounds, N, and P. The most important factors contributing to or limiting erosion include: degree of slope, susceptibility of soil to detachment, crop cover, rainfall, and presence of erosion control practices (Cook et al., 1996; Dillaha et al., 1986; Liu et al., 2000).

7.2.4 Runoff Control from Land Application Fields

Runoff from the immediate CAFO operation is best controlled at the source as described above. However, runoff control in a land application of animal waste is not as easily managed. The large areal coverage typical in land application makes management of the waste more difficult. In most applications, the primary stressor of concern will be the nutrients. Nitrogen as found in animal waste is soluble and will be transported via the water (Eghball 2000). Phosphorus, however, is particle-bound and will be transported through erosion and sediment transport. Effective controls for phosphorus will require measures to prevent the detachment, transport, and deposition of soil particles to a receiving water. Typical erosion control strategies may be used to minimize the SSAS and associated stressors delivered to a water body.

In a land application of waste, the most effective management for SSAS is to retain the soil and solids applied to the field. There are three primary points to reduce the SSAS from land application: 1) reduce soil detachment, 2) reduce transport within the field, and 3) trap sediment after the field.

7.2.4.1 Reducing Soil Detachment

To effectively reduce the soil particle detachment, the energy from a falling rain droplet must be adequately dissipated. Crop cover and crop residue may dissipate energy to varying degrees depending on the extent and type of coverage (Woo et al., 1997). Accepted conservation practices such as conservation tillage, cover crops, contour farming, buffer strips, riparian buffer, and effective pasture management may significantly reduce the soil detachment due to direct rainfall.

Conservation tillage reduces vulnerable soil exposure by maintaining a cover crop and/or crop residue on the soil surface. Examples of conservation tillage include preparation of seedbed bands only for rowcrops, chisel plowing or disking to incorporate plant residues vertically into the soil surface rather than turning under as with a traditional plow. Approximately 45% of crop production in the US occurs with conservation tillage. Use of reduced tillage is not conducive to incorporation of applied manure. Similarly, tillage of pastureland or hay production field would not be done. Chisel plow type injection could be used on these lands to a limited extent. Leaving crop residues on the soil and planting cover crops will reduce raindrop impact on the soil, thus reducing the detachment of soil particles that could erode.

On sloping land, contour strip fields may be used to control water flow (Liu et al., 2000). Alternate strips of different crops are planted perpendicular to the slope to reduce water velocity and retain sediments. Crop rotation may reduce runoff by including a hay type crop between row crop years. The potential soil erosion from hay is much less than row crops. Provision of buffer zones, terraces, filter strips, and windbreaks may all reduce soil erosion by slowing the speed of water and wind across the soil surface. These measures may also collect particulates in motion, preventing them from reaching larger streams.

Proper pasture management may reduce pollutant movement. The best time to apply manure to hay acreage is subsequent to removal of the last crop. Then there would be a substantial time for the manure to be absorbed with little risk of bacterial contamination of harvestable crops. Similarly, manure may be applied to wheat and oat fields after harvest of the grain and straw. The manure could be absorbed prior to seeding of the next crop or as the soil is prepared for the next crop.

Atmospheric losses of N may be curtailed by incorporating manure either by direct injection or by tilling within 24 hours after application. For some crops, the incorporation of manure may be combined with preparation for seeding. One factor in reducing NH₃ volatilization from soil is that most agricultural soils have pHs in the range of 6 to 7.5. Ammonia will tend to remain in soil at that pH.

7.2.4.2 Reducing SSAS Transport within a Field

To effectively reduce the transport of SSAS within a field, techniques to minimize runoff, increase infiltration, and trap sediments are used. Similar conservation techniques described for reducing soil detachment may also reduce the within-field transport. The use of cover crops and crop residue will effectively reduce the runoff velocity and trap sediments. The type and extent of cover crop or crop residue will control its effectiveness. Contour farming, strip cropping, and conservation tillage may all effectively reduce within-field transport. Diversion of runoff from up-slope areas may also reduce the runoff on the targeted field.

Cover crops also immobilize nitrogen and phosphorus effectively converting the elements into slower release forms. Along streams, other management practices may be implemented to reduce the potential for eroded material to enter the water. Riparian buffers of trees, grass, and shrubs may reduce transport of material to the stream. They are discussed in more detail in the next section.

Many agricultural areas of the United States require drainage of the soil by tile to be fully productive. In those areas, limiting of the amount of applied nutrients would be the best way to control the movement of nutrients to drainage paths. Areas of the US that have significant karst landforms are also susceptible to significant losses of N and P in drainage water (Stoddard et al., 1998). Some of the soils are quite shallow and may rapidly allow movement of water and dissolved nutrients to streams and lakes

7.2.4.3 Trapping Sediment after the Field

The final point of control is trapping sediment after the field. Though this should effectively reduce the sediment load to a water body, this technique is treating the symptom and not addressing the problem. Efforts should be made to reduce the generation of SSAS, not simply trap or intercept them. Trapping strategies include grassed buffer strips, diversions, detention basins/ponds, riparian buffers, terraces, and wetlands. These solutions generally approach a more engineered solution versus the first two phases of erosion prevention (preventing soil detachment and within-field transport). Efficiencies vary based on design and operation of the control structure (Butler and Karunaratne, 1995). In addition, many of the strategies have multiple functions in the prevention of erosion as shown as in Table 7.1. These strategies are used alone and in combination to address the erosion problem.

Table 7.1 Functions of soil conservation practices (Adapted from USEPA, 2001a).

Conservation Practice	Soil Detachment	Within Field Transport	Sediment Retention
Conservation tillage	X	X	
Contour or Cross-slope Tilling		X	
Contour strip cropping/Contour Buffer strips	X	X	X
Cover crops	X	X	
Crop rotation	X	X	
Diversions		X	X
Field borders		X	
Filter strips		X	X
Grassed waterways	X	X	X
Ponds		X	X
Riparian buffers		X	X
Sediment basins		X	X
Terraces		X	X
Wetlands			X

Depending on topography, waterways on a farm could lead to sediment traps or constructed wetlands that would intercept much of the sediment and nutrient load that leaves the fields. Periodic cleaning of these structures would be necessary to retain capacity.

Riparian zones are areas usually associated with the banks of river or stream corridors and are areas where subsurface flow (groundwater runoff or base flow) reaches either the ground surface or near surface before contributing to stream flow, causing elevated water tables and high soil moisture condition that typically support a variety of vegetation. Riparian zones impart a variety of beneficial influences upon streams such as reducing sediment and nutrient loads, mitigating the severity of flooding, and increasing soil permeability and soil organic content.

In addition to the physical benefits just mentioned, riparian zones may also exert a chemical influence on groundwater runoff, most notably conditions that favor nitrate reduction. The ability to support nitrate reduction is closely tied to the geology and hydrology of a watershed, and the extent of the riparian zone.

If the soils in a riparian zone are saturated, and anaerobic or anoxic conditions exist, nitrate reduction is possible. In addition to the favorable conditions noted, not only must the flow path of groundwater intersect or flow through the riparian zone before discharging to the stream, but also the area where groundwater recharge occurred must be in an area where elevated nitrate levels exist in the soils. In other words, recharge to the groundwater system may occur over a large portion of a watershed or field, but not all of this recharged water will follow a flow path through a riparian zone. Some of the water may move into deep groundwater flow regimes, well below the influence of the riparian zone and into another groundwater system. Some groundwater may appear as spring flow, also bypassing the riparian zone. Still other groundwater may follow a flow path that travels below the riparian zone (rather than laterally through the riparian zone), then vertically upward into the stream minimizing any contact time within the riparian zone.

Seasonal variations also affect the influence of the riparian zone. During wet seasons, the water table may be elevated and intersect the stream creating the favorable conditions for nitrate reduction. During drier periods, the water table may drop, and groundwater runoff that previously would have followed a flow path through the riparian zone will now flow beneath the zone without any reducing effects.

Finally, even if the flow path that groundwater runoff follows is lateral through the riparian zone, only runoff that originates in an area that has elevated nitrate will experience possible nitrate reduction. This becomes important when areas are chosen for the application of animal waste. If the goal is to incorporate the benefits of a riparian zone into the management of animal waste, the waste must be applied in areas where the runoff generated, both surface and subsurface runoff depending on the benefit desired, will flow through the riparian zone.

The two primary nutrients in animal waste behave almost opposite to runoff or precipitation. Phosphorus (P) is primarily transported as particulate P in runoff, although there is an important component of soluble P, whereas nitrate is highly soluble and is more readily leached into the groundwater. As noted previously, this may be a factor in deciding where to place animal waste within a field or watershed. Precipitation events that are insufficient to produce runoff that would carry P to a receiving water body are typically insufficient to mobilize sediments. Finally, even if the flow path that groundwater runoff follows is lateral through the riparian zone, only runoff that originates in an area that has elevated nitrate will experience possible nitrate reduction.

7.3 Composting of CAFO wastes

Composting of CAFO and AFO wastes benefits the environment because nutrients contained in manure, livestock carcasses, and other materials are converted to stable forms in the compost. Therefore, these nutrients are less likely to leach into groundwater or to be carried off with surface runoff. In addition, the total mass of material is reduced in the composting process. Compost may be easily stored until conditions are favorable for land application and therefore possibly minimizing the impact to environmentally sensitive areas. Another advantage of composting is that due to high self-heating (55-65°C), the process is generally self-pasteurizing for most pathogens, provided that the minimum time and temperature conditions have been met. The main concerns of composting these types of wastes are pathogen control, nitrogen volatilization and leaching, excess available phosphorus, and economic viability of composting depending on type of system required.

7.3.1 What is Composting?

Composting is a useful tool in waste management because it may rapidly transform putrescible material to a stabilized product that may be stored, transported, and used as a soil conditioner/fertilizer (Maynard 1993). In composting, a solid-phase organic material such as manure mixed with a bulking agent (corn cobs, corn stover, straw, wood chips) serves several functions. The solid organic phase is a physical support for microorganisms, maintains pore space for gas exchange, is a source of organic and inorganic nutrients, contains diverse indigenous microbes, and provides thermal insulation. Water may be added to maintain the proper moisture content of the compost. The major form of microbial metabolism is aerobic respiration. The heat generated during the exothermic reactions of metabolism becomes trapped within the matrix causing self-heating, which is characteristic of the composting process. The critical elements of successful composting are a proper carbon to nitrogen ratio (15-40 to 1), adequate oxygen supply, temperature control, maintenance of moisture, and provision of an adequate time period to reduce pathogens to appropriate levels. All composting systems may be described by their means of regulating the initial oxygen supply and maximum temperature (Finstein and Hogan 1993). For a more in-depth review of all the possible composting configurations based on oxygen supply and maximum temperature, along with a brief discussion of whether that type of system is currently practiced and, if practiced, how the technology is faring, see Finstein and Hogan (1993). For a review of the composting process parameters for animal wastes or other organic wastes, see the following references: Agriculture Waste Management field

handbook by the U.S. Dept. of Agriculture and On-farm composting handbook by NRAES-54 (Dougherty 1999, Rynk 1992).

7.3.2 Composting systems

In order to avoid a long and lengthy list of composting systems in practice and vendor specification to define composting systems, the basic outlook of man over mechanical intervention required to compost will be discussed in order to save space. The current practices and system types utilized by poultry, cattle/dairy, and swine will be discussed later. There are basically two types of composting systems, interventionary and non-interventionary (Stentiford 1993).

7.3.2.1 Interventionary Systems

Interventionary systems are systems that require mixing as an aeration process, and these systems may also have some form of supplementary aeration. These systems may take many forms such as windrows, agitated bays, stirred vessels, and multi towers. The main advantage with interventionary systems is that mixing of the waste prior to composting is not as critical as it is in non-interventionary systems. These systems are better suited for the composting of putrescible wastes because they allow the composter to adjust parameters, such as moisture and amount of bulking agent, while the composting process is ongoing.

7.3.2.2 Non-Interventionary Systems

In non-interventionary systems, the initial conditions of the feed material are critical for successful operation. Non-interventionary systems consist primarily of aerated static piles and silo systems. The silo system was not proven to be an effective method of composting due to aeration and moisture control problems inherent with the system design. The aerated static pile has proven effective with composting many wastes, but it must be emphasized that this system is not dynamic. The system must be carefully constructed in order to provide uniform heating and moisture throughout the process since no other intervention will occur. This means that the risks of composting failure to achieve the desired results of pathogen destruction and nutrient stabilization are higher with this type of system (Lufkin 1996, Mathur 1990, Sartaj 1997).

7.3.3 Comparison of Interventionary and Non-interventionary Systems

Each type of system has its merits and associated cost. The interventionary systems offer the operator improved control, shorter processing time, and reduced land use, but with these advantages comes increased price of setup and operation. The non-interventionary systems offer the operator low setup and operational costs but requires increased land usage, increase in the time required for stabilization, and little or no control of the process (Stentiford 1993, Sartaj 1997, Vuorinen 1999-1997). Therefore, the type of process utilized to compost the CAFO and AFO waste streams must take into consideration the time frame, costs, distance to population centers, and the systems' ability to meet final regulatory requirements.

7.3.4 Composting in the Beef and Dairy Industries

7.3.4.1 Beef

Since manure from the beef cattle occupying range and pastureland is dispersed by the animals, composting in the beef cattle industry is limited to manure generated at feedlots (Kashmanian 1996). Composting is generally performed by the feedlot owners or sub-contractor at the facility. The windrow method of composting is the most commonly practiced method (Lufkin 1996, Rynk 1992, Mathur 1990).

The manure may be composted alone or by mixing the manure with locally available carbonaceous feedstocks, such as straw, newspaper, or yard trimmings. The additional carbon sources help in raising the C/N ratio and reduce the loss of nitrogen as a result of ammonia volatilization (Hong 1997, Larney 1999). The handling of the material is usually performed by either a front-end loader or a windrow turning machine. The final compost is either sold commercially for landscape and gardening or sold in bulk for crop production.

7.3.4.2 Dairy

The sources of manure readily compostable from the dairy industry are the bedding materials used in barns and partially dried manure from the open lots. Another source of material found in the dairy industry is manure solids separated from liquid collection systems. Dairy wastes from bedding and open lots may be composted as is, but the composting process benefits from the addition of high carbon substrates in order to minimize nitrogen loss due to volatilization (Hong 1983, Hong 1997). As with beef cattle, the method of composting applied by dairy farmers is windrows. The windrows are either static or forced aeration with turning methods as described above. The forced aeration systems are generally used by larger facilities that do not have the land or storage ability to deal with nutrient management issues due to the high manure load (Joshua 1998, Fernandes 1997). Some composting at dairies is performed by outside organizations and sold to commercial outlets. The dairy industry has recently adopted some practices that do not favor composting as a waste management practice. These practices are the use of bedding mats or sand in free stall areas, and many larger farms are switching over to liquid manure handling systems. The liquid systems increase the cost associated with dewatering solids and increase the amount of carbonaceous materials needed to compost. Another disadvantage of these practices is the increased moisture present at the initiation of composting requires that the compost must be turned more frequently until the moisture level becomes more favorable (40-50%). If the moisture level remains too high then the composting system has a tendency to become anaerobic which leads to the production of foul odors (Kashmanian 1996).

7.3.4.3 Composting Swine Waste

Due to the wet nature of swine waste and the current practices of water waste collection the swine industry is the least suited for composting. A small number of operations raise swine in a deep bedding method in which the waste is absorbed by straw or sawdust. After the swine are raised, this bedding material may then be composted by any number of means (Hong 1998, Lau 1993, Peterson 1998, Tiquia 1997-98). Most other systems use a liquid method for waste collection, and, therefore, the solids need to be removed from the waste stream in order to compost. The separation may be performed by several methods (centrifugation, screening, and presses) but all methods add to the cost and handling of the waste (Liao 1993, Kashmanian 1996). Due to the wet nature and the high nitrogen content of the swine manure, a readily available source of high carbon bulking materials would be necessary in order to compost this material. One area of composting that is gaining attraction in the swine industry is the composting of mortalities. This is a relatively inexpensive way to deal with mortalities since the cost of rendering and number of rendering facilities across the country is declining. Only a limited number of states allow this form of composting and the accepted methods vary slightly from state to state. The pathogens associated with the swine industry (*Salmonella typhimurium*, *Streptococcus suis*, *Bordetella bronchiseptica*, *Listeria monocytogenes*, *Actinobacillus suis*, and *Actinobacillus pleuropneumoniae*) have been shown to be sufficiently killed by the high temperatures of the composting process (Morrow 1995). The composting of mortalities is limited to normal fatalities and is not an acceptable method for the disposal of a large number of animals due to a system failure.

7.3.4.4 Composting Poultry Waste

Poultry manure is readily compostable due to the method of raising animals in confined areas and the dry nature of the material. This manure generally requires the addition of carbonaceous materials due to its high nitrogen content (Figures 7.3-7.4). Water must also be added to poultry manure and/or litter to ensure proper initial composting conditions (Flynn 1996, Hansen 1990, Spencer 1997). One of the advantages of composting to the poultry industry is the relative small land size of poultry operations, and, therefore, they do not have adequate land for application of raw manure. Composting allows the poultry producer to stabilize a waste product on a small area while creating a potential value added product. Commercial outlets for the finished material are one solution that several producers have utilized (Lufkin 1996). Most poultry operations practice composting of mortalities since it is an environmentally acceptable practice and other forms of disposal are facing increased restriction and increased cost (Kashmanian 1996). National standards for the practice of poultry mortality composting are published by the U.S. Dept. of Agriculture's National Resource Conservation Service. Many state and national guidelines are available on the web for the composting of poultry mortalities.



Photo courtesy of USDA NRCS.

Figure 7.3. Mixed compost from turkey waste.



Photo courtesy of USDA NRCS.

Figure 7.4. Turkey waste compost with wood chips and feathers.

7.3.5 Composting Concerns and Problems

The type of manure handling practice has a large impact on whether a particular farm is going to compost or not. Composting is generally practiced on farms that handle their manure in a solid or near-solid consistency. Composting is rare on farms that utilize liquid techniques for manure handling, such as swine and dairy operations. There are some exceptions because of solids separations techniques, but these add cost to the final operation and may therefore be impractical in some operations (Liao 1993). In order to address the high moisture and high nitrogen content of the waste, a locally available source of carbonaceous materials must also be readily available (Dougherty 1999, Rynk 1992, Hong 1983). The volatilization of NH_3 is a major concern in the composting of manures because it lowers the fertilizer value of the finished compost and produces environmental air quality issues.

7.3.5.1 Nutrients.

There has been some study of the effect of C/N ratio on the volatilization of NH_3 from poultry and sewage sludge composting operations (Hansen 1990, Hong 1997, Kirchmann 1989, Larney 1999, Lopez-Real 1996). In order to minimize the loss of NH_3 , a higher C/N ratio is more favorable. The use of either a soil or carbon source cover has also been shown to minimize ammonia volatilization (Hansen 1990). Another factor that seemed to help in the retention of nitrogen during composting is the recycling of compost back into the initial feed material. This practice, though, is generally only used to inoculate the composting system, since it reduces the overall mass loss and requires additional handling of the same material (Larney 1999, Hansen 1990). No information was found on the nitrogen content of potential leachate from composting materials.

7.3.5.2 Pathogens

Pathogens associated with these waste streams fall into two categories, primary and secondary pathogens. The primary pathogens consist of bacteria, viruses, protozoa, and helminths. When the

composting process is run correctly, it is very efficient at destroying primary pathogens, and exposure-related infectious disease from primary pathogens among compost workers has not been documented. (Epstein 1993, Bertoldi 1988). To be effective at pathogen removal the composting process must attain a temperature greater than 55°C for more than three consecutive days (Choi 1999, Rynk 1992, Bertoldi 1988). Although there are no federal regulations for the composting of manures, the US EPA addresses pathogen reduction guidelines, which may be applied to manure, for the composting of biosolids in the September 1989 report entitled "Environmental Regulations and Technology: Control of Pathogens in Municipal Wastewater Sludge," EPA/625/10-89/006, p21, To be considered a PFRP, the composting operation must meet certain operating conditions. These regulatory conditions are specific to the method of composting practice. For windrow composting, the sludge must attain a temperature of 55°C (131°F) or greater for at least 15 days during the composting period. In addition, during the high-temperature period, the windrow must be turned at least five times. If the static aerated pile or the within-vessel method is used, the sludge must be maintained at operating temperatures of 55°C (131°F) or greater for 3 days. This temperature requirement is effective at removing most, if not all pathogens. The removal of *Salmonella* and other pathogens during the compost process has been demonstrated for a variety of animal wastes. Lawson (1999) showed the removal of pathogens during the composting of poultry carcasses and litter. Lung et al., 2001, demonstrated the removal of *Salmonella* and *E. coli* O157:H7 during the composting of cow manure. This study showed no removal of either pathogen in reactors held at room temperature. Tiquia et al., (1998) in a study of pig litter composting *Salmonella* was reduced from 1700 per gram to below detection limit and a greatly reduced (not specified) population of fecal coliforms and streptococci. The fecal coliforms and streptococcal numbers were below the amount found in commercially available potting mixes. The only primary pathogen of concern is the possible regrowth of *Salmonella* by reinoculation of unfinished compost (Burge 1987, Russ 1981, Tiquia 1998). Other pathogens are not addressed in recent literature. This has been shown to be a possible problem from the composting of biosolids/sewage sludge and therefore could also be a potential problem in the composting of manures (Burge 1987). There has been some study of the suppression and regrowth of *Salmonella* in composts at different ages of material by Sidhu, 2001. In this study, *Salmonella* was inoculated into sterilized and regular composts of various ages. *Salmonella* regrowth was similar in all sterilized composts, with terminal populations of about 100 per gram. The growth of *Salmonella* was suppressed in all non-sterilized composts regardless of the age of the material. The suppression ability of the compost showed a slight decline with time, and, therefore, more study is needed to look at the effect of long term storage and regrowth of pathogens. Good composting practices that avoid cross contamination of raw and finished product alleviates this problem. Storage of compost for 30 days after the active phase of composting has been shown by Gibbs, 1998, to reduce the number of *Giardia* cysts to below detection limits (<10 cysts/gram).

"Secondary pathogens" fungi and other microorganisms produced during the composting process are of concern. The largest health threat seems to come from a secondary pathogen, the heat tolerant fungus *Aspergillus fumigatus*, and several related fungi, which cause "aspergillosis" (also known as "farmer's lung" or "brown lung" disease). This fungus, a well-known product of silage, manure compost, and wastewater sludge compost, grows well on decaying vegetable matter at temperatures above 45°C, and thus survives most of the composting process. Infections in susceptible individuals (including those on immunosuppressant drugs, antibiotics, adrenal corticosteroids, or with pulmonary disease, asthma, and certain other infections) may be severely debilitating and even fatal. Such infection appears related to high levels of "infective units" in dusts, perhaps reflecting interaction with other materials as irritants, because the organism itself is ubiquitous and not regarded as an off-site or product-related problem (Epstein 1993).

7.3.6 Land Application of Compost

The land application of composted manure has been shown to minimize nitrate leaching into the ground waters (Figure 7.5). The amount of nitrate leached in reported studies was lower from compost-amended plots when compared to conventional fertilizer or direct manure application (Dalzell 1987, Grey 1999). In a study of groundwater by Maynard, 1993, when compost was applied at rates to supply all nitrogen requirements, the compost-amended soils had < 10 mg/kg of nitrate as compared to >14.7 mg/kg for conventional fertilizer application. In a reclamation study of forest soils by Insam, 1997, using various composted and non-composted soil amendments, the nitrate levels below the compost plots were only increased a small amount, whereas the non-compost plots had a highly elevated level of nitrate present in the ground water (<150 mg/L). A three year agricultural study by Diez (1997), which compared compost-amended fields to controls and fields with chemical fertilizers under two different irrigation systems, had mixed results. Under an efficient irrigation system, the compost and control fields had similar low levels of nitrate in the ground water, but under conventional irrigation practices (field flooding in Spain) the compost and chemical fertilizer treated plots had similar nitrate levels. Jakobsen, 1996, performed a pot study looking at the effects of compost-amended soil on mineral availability, soil conditions, and nitrate availability after compost application and after additional fertilizer application. There was some nitrate leaching during winter months from the compost-amended soils after chemical fertilizer was applied but the amount was significantly less than the non-amended control soils. Jakobsen's study also concluded that if compost is applied at a rate to supply the phosphorus needs of the crop, the soil's pH was raised, the cation exchange capacity was maintained, and the soil structure was improved even after a crop had been raised. Another indicator of the stability of nutrients in compost is the agronomic value for estimating availability of nutrients from compost. Values for the availability of nitrogen range from 7 to 25 percent, whereas phosphorus is 100 percent, and potassium is 80 percent for the first year (Grey 1999, Tester 1990, Larney 1999).

7.4 A Strategy Requiring Some Additional Research– Anaerobic Digestion

7.4.1 Technology Description

Anaerobic digestion may be defined as the biodegradation of organic materials in the absence of oxygen. This treatment is particularly appropriate for manure with a high organic (BOD) content. The resulting product is deodorized, has a substantially lower organic load, and has greater nutrient availability (N and P) for crops. The process converts dissolved and particulate matter into a gas, which is primarily composed of methane and carbon dioxide, via a series of interrelated microbial metabolisms (Magbanua, et. al, 2000).

Although different types of anaerobic digester designs exist, only covered lagoons, complete-mix digesters, and plug-flow digesters may be considered commercially available because they are the only ones that have been implemented successfully at ten or more sites (U.S. EPA, 2001).

7.4.1.1 Covered Lagoons

For agricultural waste, anaerobic lagoons are the most common and simplest anaerobic digestion treatment systems (Copeland et. al, 1998; McNeil Technologies, 2000). A covered lagoon digester typically consists of an anaerobic combined storage and treatment lagoon, an anaerobic lagoon cover, an evaporative



Photo courtesy of USDA NRCS.

Figure 7.5. Truck mounted spreader applying compost to a field.

pond for the digester effluent, and a gas treatment and/or energy conversion system. Following treatment, the digester effluent is often transferred to an evaporative pond or to a storage lagoon prior to land application (McNeil Technologies, 2000).

The advantages of covered anaerobic lagoons are the reduction of lagoon odor, exclusion of rainfall from the lagoon, recovery of usable energy, reduction of ammonia volatilization, and reduction of methane emissions. There are also significant labor savings involved in handling manure as a liquid and being able to apply lagoon waters to the land through irrigation (U.S. EPA, 2001c). The limitations of covered anaerobic lagoons include the cost of installing a cover, or the occasional need for cover maintenance such as rip repair and rainfall pump-off. Spills and leaks to surface and ground water may occur if the lagoon capacity is exceeded, or if structural damage occurs to berms, seals, or liners (U.S. EPA, 2001c).

7.4.1.2 Complete Mix Digester

A complete-mix digester is a biological treatment unit that anaerobically decomposes organic waste using controlled temperature, constant volume, and mixing. These digesters may accommodate the widest variety of wastes and are generally used to treat waste with 3 to 10% total solids and adequate volatile solids to produce enough methane to maintain digester temperature (Moser, 2000a,b). The digesters are usually above ground, heated, insulated, round tanks; however, the complete-mix design has also been adapted to function in a heated, mixed, covered earthen basin. Mixing may be accomplished with gas recirculation, mechanical propellers, or liquid circulation. Like covered lagoon systems, digester effluent from complete mix digesters is frequently stored in evaporative ponds. The outflow is recycled onto cropland.

7.4.1.3 Plug-flow Digester

A plug-flow digester is a heated, unmixed, rectangular tank. New waste is pumped into one end of the digester, thereby displacing an equal portion of older material horizontally through the digester and pushing the oldest material out through the opposite end (Moser, 2000a,b). The tank is usually built in the ground and is long and slim and the ratio of the length to the width should be between 3.5:1 and 5:1 (U.S. EPA, 2001c). The outflow may go into an outside storage pond to be held until the manure is recycled onto cropland (Goodrich, 2001).

Overall, some advantages of anaerobic digestion include the opportunity to reduce energy bills, produce a stabilized manure, recover a salable digested solid by-product, reduce odor and fly breeding, and produce a protein-rich feed from the digested slurry (U.S. EPA, 2001). However, the costs of installing an anaerobic digester that collects the biogas may be quite high. Therefore, their economic viability is often dependent on the price at which the excess energy may be sold to a local electrical utility (Prairie Agricultural Machinery Institute, 1997).

7.4.2 Application

Anaerobic digesters are, possibly, the most trouble free, low maintenance systems available for the treatment of animal waste. Farm-based manure facilities are perhaps the most common use of anaerobic digestion technology (Lusk, 1998). Properly designed anaerobic lagoons are used to produce biogas from dilute wastes with less than 2 percent total solids, including flushed dairy manure, dairy parlor wash water, and flushed hog manure. Complete-mix digesters may be used to decompose animal manures with 3 to 10 percent total solids. Plug-flow digesters are used to digest thick wastes (11 to 13 percent solids) from ruminant animals, including dairy and beef animals (U.S. EPA, 2001).

Anaerobic digestion is one of the few manure treatment options that reduce the environmental impact of manure and produce a commodity – energy – that can be used or sold continuously. It is more extensively used outside of the United States where treatment of animal waste has been a concern for a longer time (Moser, 2000a,b).

U.S. livestock operations currently use four types of anaerobic digester technology: slurry, plug-flow, complete-mix, and covered lagoons. As of 1998, 28 digester systems are in operation at commercial swine, dairy, and caged-layer farms in the United States. Table 7.2 provides a numerical status report of farm-based anaerobic digesters in the United States. The data excludes 65-70 digesters that were installed on or were planned for beef farms, and digesters that are primarily university research oriented (Lusk, 1998).

Table 7.2. Status of Farm-Based Digesters in the United States

Type	Slurry	Plug	Mix	Lagoon	Other	Total
Operating	7	8	6	7	0	28
Not operating	0	18	10	1	0	29
Farm closed	0	11	5	1	0	17
Under construction/planning phase	0	2	4	0	4	10
Planned but never built	0	8	1	1	0	10
Total	7	47	26	10	4	94

During the 1990s, 18 systems were installed – more than doubling the number of successful systems installed during prior years. In 23 of the 31 systems, the captured biogas is used to generate electrical power and heat (U.S. EPA, 2001).

Because of the differences in the manure produced from different animals, a system to make methane from dairy cow manure is quite different from a digester for manure from swine. For dairy cows, a plug-flow digester system works well for collecting and breaking down manure and capturing the gas produced from this process. A completely mixed digester is better for swine manure (Goodrich, 2001).

Beyond their ability to manufacture biogas, digester designs based on use of thicker manures may offer the most benefits of the systems evaluated to date. Plug-flow digestion and its slurry cousin are economically sensitive to co-product use and other offsets from current manure management practices, but they are less expensive and technically easier to operate and maintain than a comparable complete-mix digester. Covered lagoon digesters appear to have economic merit for the large number of swine and dairy operations in the Southeast and West. Complete-mix digesters generally have higher capital costs and operating and maintenance requirements than slurry-based, plug-flow, and covered lagoon digesters. This will generally limit complete-mix digester applications to very large farms or centralized facilities, or to farms having waste streams with total solid concentrations too low for slurry and plug-flow digestion and to locations where the climate is too cold to economically justify covering an anaerobic lagoon (Lusk, 1998).

7.4.3 Operation and Performance

The successful operation of a properly designed anaerobic digester is dependent upon two variables, feed rate and temperature. All other operational issues are related to ancillary equipment maintenance. At face value, the performance data are not encouraging to a farmer considering whether to install an anaerobic digester as a waste treatment option. Overall, the chance for failure is approximately 50% in the United States (Lusk, 1998). Among the types of farm-based digesters actually built, the failure rates for complete-mix and plug-flow systems are staggering: 70% and 63%, respectively. For covered lagoon digesters, the failure rate is 22% (Lusk, 1998). However, a properly designed, constructed, and operated anaerobic digester is a low maintenance system that is very forgiving and not likely to create emergency situations that can be experienced with many alternative waste management systems (Saele). The failures of lagoons and the resulting waste spills have brought much of the recent critical attention to animal agriculture, and some have called for phasing out lagoons (Copeland, 1998).

Historically, one of the major problems with anaerobic digestion has been its unreliability. Because of the complex association of different types of bacteria, anaerobic digesters are prone to problems and have a higher risk of breakdown than other systems. The process is also more difficult to control (Cord-Ruwisch, 2001).

A review of anaerobic digestion project case studies revealed that the most common reasons for system failures include poor design and installation and poor equipment specification. Poor equipment and materials selection are also common reasons for failure. Other reasons that explain the failure of some anaerobic digestion projects include: insufficient gas production due to build-up from straw and foam, an inability to heat the digester to the desired level, insufficient insulation and agitation, grit deposition, engine corrosion, inadequate screening and sedimentation process, engine overheating, valve and pump problems, and maintenance costs (Lusk, 1998).

The improved reliability of newer systems and increased understanding of the biological systems that operate in an anaerobic digester suggest that the reliability of systems will continue to improve as long as lessons of past system failures are heeded (Lusk, 1998).

In spite of the chances of failure, survey farmers who have installed and continue to operate digesters are generally satisfied with their investment decisions. Some chose to install digesters for non-economic reasons, primarily to control odor or contain excess nutrient runoff. Farmers have found that the returns provided from electricity and co-product sales from the digester, however limited, are preferred to the sunk-cost of conventional disposal that provides zero return on investment. Moreover, without the environmental benefits provided by anaerobic digestion technology, some might have been forced out of livestock production (Lusk, 1998).

The anaerobic digestion process must be evaluated and implemented at each site. As a result, few meaningful generalizations may be made. Factors required for successful project implementation include: an adequate match of digester type to the farm's manure management program, competent design and installation, which simplify digester operation and maintenance, maximization of co-product use to enhance economic performance, and overall, an accommodating farm management and its willingness to incorporate the uncertainties of a new technology (Lusk, 1998).

7.4.4 Fuel Gas Production

Anaerobic digestion is the only waste management strategy available that provides the option to recover methane for energy production (McNeil Technologies, 2000). According to the USEPA AGSTAR Industry Directory for On-Farm Biogas Recovery systems, there are currently 89 agricultural methane recovery sites operating in the United States. A majority of the units are situated in the eastern region of the country. The digester technologies used to collect biogas from swine facilities include covered anaerobic lagoons, complete mix digesters, plug flow reactors, induced blanket reactors, and sequencing batch reactors. Although a sequencing batch reactor has been used for anaerobic digestion at one swine facility in the United States, this technology is considered to be experimental (McNeil Technologies, 2000).

Daily biogas production at installed farm-based anaerobic digesters in the United States varies from 24,000 to 75,000 cubic feet, or an energy equivalent of 13 to 42 million British thermal units (assuming 55 percent methane content for biogas). Approximately 35 percent of the volatile solids from dairy manure and 60 percent from swine or beef manure may be converted to biogas and removed from the manure liquid (U.S. EPA). The induced blanket reactor has achieved 80 % reduction of volatile solids.

Covered lagoon digesters and complete mix digesters differ in their methane production characteristics, and energy conversion systems that rely on methane from anaerobic digesters should be chosen according to the end-use objective for the system. Complete mix digesters may produce heat and electricity at a constant rate throughout the year because heat recovery may be used to heat the digesters in the winter. Covered lagoon digesters may consistently produce biogas only in months when the temperature exceeds 39 °F (Figure 7.6). Reactors may be successful in the northern United States if careful attention is paid to heat management. The facilities that are located in the southern portion of the country are usually warm enough for cost-effective energy recovery from covered lagoon digesters. Complete mix digesters may be used in cold or warm climates. If odor control is the only objective, either covered lagoon or complete mix digesters may be used, but odor control will be less effective in the winter for covered lagoon digesters in the south (McNeil Technologies, 2000).



Photo courtesy of USDA NRCS.

Figure 7.6. Covered manure tank generating methane in Iowa.

A review of recent dairy waste anaerobic digestion studies has established that most engineers anticipate a 50 percent conversion of volatile solids to gas. The planned Three-Mile Farm (Oregon) dairy waste thermophilic anaerobic digestion facility is expected to achieve a 50 percent volatile solids conversion to gas. The C. Bar M. (Idaho) plug flow anaerobic digester facility anticipated a 50 percent conversion of dairy waste volatile solids to gas. The recently completed Myrtle Point (Oregon) feasibility study utilizing the *gravity separation contact process* anticipated a 50 percent conversion of dairy waste volatile solids to gas. Relatively high loading rates were anticipated in each case. The organic loading rates varied between 5.6 and 6.4 kg/m³/d (Burke, 2001).

7.5 Technologies Requiring Significant Additional Research Before Implementation-Aerobic Digestion-Wetlands-Land Reclamation

7.5.1 Aerobic Digestion

The use of aerobic digestion to treat livestock wastes was born out of a need to reduce the pollution of both surface and ground water supplies, which had been caused by the spreading of manures, and the unavailability of land during much of the year for immediate spreading of animal wastes. For these reasons, farmers began to look for a low-cost, manure storage method that would not give rise to intolerable odors and insect breeding (U.S. EPA, 1972).

One of the simplest methods of low odor waste treatment is the aerobic biological treatment process. Aerobic treatment for the removal of biodegradable organic matter from liquid wastes is an odorless process and consists of two phases operating simultaneously. One phase is biological oxidation that has by-products such as carbon dioxide and water. The second phase utilizes the energy from the oxidation phase for synthesis of new cells (U.S. EPA, 1972). The degree of oxidation depends on the amount of oxygen

provided, the reaction time allowed in the treatment process, and temperature. The relatively strong oxidizing environment leads to a more extensive breakdown of organic compounds, with water, carbon dioxide, nitrates, sulfates, and other simple molecules being the products (Bicudo, 2001). With conventional aerobic digestion, substantial reductions in total and volatile solids, biochemical and chemical oxygen demand, and organic N may be realized.

An aeration basin typically is used for the aerobic digestion of municipal and industrial wastewater biosolids. In contrast, several reactor types, including oxidation ditches and mechanically aerated lagoons, as well as aeration basins, have been used for the aerobic digestion of animal manures. Under commercial conditions, the oxidation ditch has been the most commonly used because it may be located in the animal housing unit under cages for laying hens or under slatted floors for swine (U.S. EPA, 2001).

7.5.1.1 Types of Aerobic Digestion Technologies

7.5.1.1.1 Oxidation Ponds

The oxidation pond (naturally aerated lagoon) is a shallow pond that uses a natural system of evaporation as a means of effluent reduction. In an aerobic lagoon or oxidation pond, there must be an abundance of dissolved oxygen available in the water for the aerobic bacterial and other organisms to interact in the biochemical process that decomposes or breaks down the organic materials in the liquid waste. Normally, aerobic lagoons range from 3 to 5 feet deep. If oxidation ponds are properly constructed and hold the wastes for a sufficient time, a good destruction of coliform organisms and a satisfactory reduction of BOD₅ occur. The effluent is usually high in dissolved oxygen (U.S. EPA, 1972). The main advantages of aerated lagoons are that aerobic digestion tends to be more complete and it produces fewer odors than anaerobic digestion (McNeil Technologies, 2000).

Because of the large surface area required, oxidation ponds have not found favor with livestock producers. Vast amounts of land are required – as much as 25 times more surface area and 10 times more volume than an anaerobic lagoon 10 feet deep. Thus, naturally aerobic lagoons are impractical for primary oxidation and are generally not recommended for treatment of livestock production wastes (Barker, 1996). Their use has been essentially limited to receiving effluent from anaerobic lagoons and other treatment units.

7.5.1.1.2 Mechanically Aerated Lagoons

A mechanically aerated lagoon is similar to a stabilization pond except that it is equipped with one or more electrically powered aerators that treat effluent by mixing it with air (Water for the World). Mechanically aerated lagoons combine the odor control advantages of aerobic digestion with relatively small surface requirements. Aerators are used mainly to control odors in sensitive areas and for nitrogen removal at limited land disposal sites (Barker, 1996). A major disadvantage of mechanically aerated lagoons is the expense of continually operating electrically powered aerators. Larger anaerobic lagoons may provide similar performance with less expense (Barker, 1996).

7.5.1.2 Application

Conventional aerobic digestion is a process used frequently at small municipal and industrial wastewater treatment plants for biosolids stabilization. Conventional aerobic digestion is an option for all swine and poultry operations where manure is handled as a liquid or slurry. With proper process design and operation, a 75 to 85 % reduction in BOD₅ appears achievable, with a concurrent 45 to 55 % reduction in

COD, and a 20 to 40 % reduction in total solids. In addition, a 70 to 80 % reduction of the N in both poultry and swine wastes via nitrification-denitrification also appears possible. Total P is not reduced, but the soluble fraction may increase (U.S. EPA, 2001).

Unlike anaerobic digestion, aerobic digestion has not been adapted to any significant degree by the poultry, dairy, or swine industries, although a number of research and demonstration scale studies were conducted in the late 1960s and early 1970s. Problems related to process and facilities design, together with the significant increase in electricity costs in the early to mid-1970s, led to a loss of interest in this animal waste treatment alternative. It is possible that no aerobic digestion systems for animal wastes are currently in operation in the poultry and swine industries.

7.5.2 Wetlands

7.5.2.1 Constructed Wetlands

Constructed wetlands (or treatment wetlands) are man-made, shallow ponds or channels that have been planted with emergent aquatic plants, and are designed, built and operated specifically for wastewater treatment. They rely upon natural microbial, biological, physical, and chemical processes to treat wastewater. To allow optimum process control, water control structures such as gates, valves and dikes have been engineered to control the flow direction, hydraulic retention time, and water level. They are typically constructed with uniform depths and regular shapes near the source of the wastewater and often in upland areas where no wetlands have historically existed. Constructed wetlands are regulated as wastewater treatment facilities and may not be used for compensatory mitigation (USEPA, 2000b).

7.5.2.2 Restored Wetlands

Created or restored wetlands are designed, built (or restored), and operated primarily for wildlife habitat and should not be confused with constructed wetlands. In an effort to mimic natural wetlands, habitat wetlands often have a combination of features such as varying water depths, open water and dense vegetation zones, vegetation types ranging from submerged aquatic plants to shrubs and trees, nesting islands, and irregular shorelines. They are frequently built in or near places that have historically had wetlands and are often built as compensatory mitigation. Created and restored wetlands are generally inappropriate for CAFO applications and are not discussed further.

7.5.2.3 Enhancement Wetlands

Enhancement wetlands are constructed wetlands providing polishing (advanced or tertiary treatment) of wastewater that has been extensively pre-treated, usually to secondary treatment standards. They are often designed, built, and operated for both wastewater treatment and other functions, such as wildlife habitat, outdoor classrooms, or recreational areas. While there may be applications for enhancement wetlands as a tertiary treatment process in certain circumstances, they are generally inappropriate for CAFO applications and are not discussed further.

7.5.2.4 Free Water Surface (FWS) Wetlands

Constructed wetlands have been classified in the literature and by practitioners into two types. Free water surface (FWS) wetlands, also known as surface flow (SF) wetlands, resemble natural wetlands in appearance because they contain aquatic plants that are rooted in a soil layer on the bottom of the wetland, and water flows through the leaves and stems of plants (Figure 7.7).

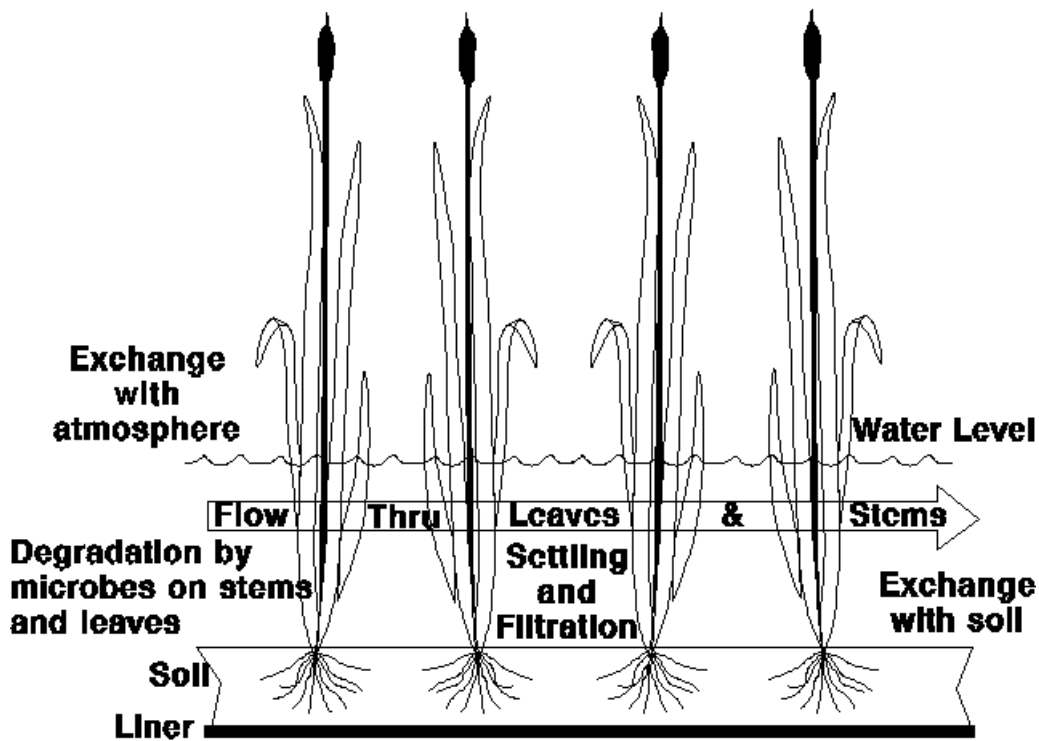

Figure 7.7. Free Water Surface (FWS) Wetland.

7.5.2.5 Vegetated Submerged Bed (VSB) Wetlands

Vegetated submerged bed (VSB) systems, also known as subsurface flow (SSF) wetlands, do not resemble natural wetlands because they have no standing water (Figure 7.8). They contain beds of media such as crushed rock, small stones, gravel, sand, or soil that has been planted with aquatic plants. When properly designed and operated, wastewater stays beneath the surface of the media, flows in contact with the roots and rhizomes of the plants, and is not visible or available to wildlife.

7.5.2.6 Reciprocating (ReCip) wetlands and vertical-flow (VF) wetlands

Reciprocating (ReCip) wetlands and vertical-flow (VF) wetlands are modifications of the VSB process. ReCip wetlands reciprocate flow back and forth between two VSBs in parallel in a way that allows the VSBs to alternate between saturated (anaerobic) and unsaturated (aerobic) conditions (Behrends, et al., 1996). VF wetlands are similar in design and operation to typical vertical flow, intermittent or recirculating sand or gravel filters, which have been planted with aquatic plants.

7.5.3 Treatment Mechanisms

The primary pollutant removal mechanisms for BOD₅ and solids (TSS) are physical removal and biodegradation. Physical mechanisms include impingement on plant or media surfaces, entrapment in plant parts or media, and sedimentation. All of these mechanisms are enhanced by the tortuous flow paths and quiescent hydraulic conditions found in wetlands. Once materials are removed from the water column by physical mechanisms, biodegradation occurs. Obligate and facultative anaerobic conditions predominate in VSBs and FWS wetlands, while the operating characteristics of ReCip and VF wetlands promote alternating anaerobic and aerobic conditions.

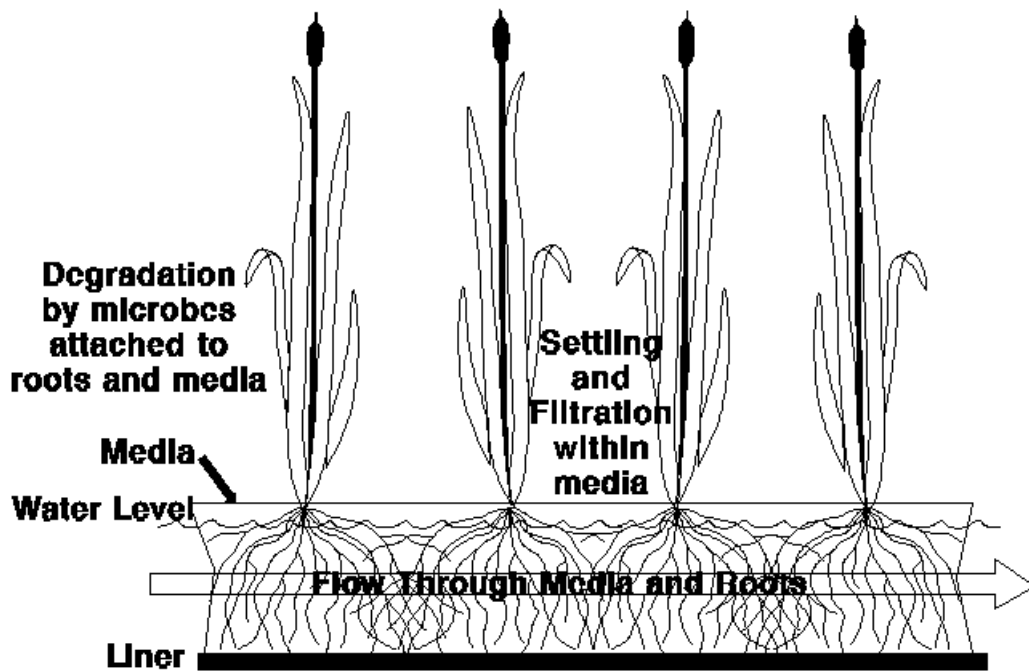

Figure 7.8. Vegetated Submerged Bed (VSB) Wetland.

For CAFO wastewaters (high BOD₅ and ammonia concentrations) in VSBs and FWS wetlands (shallow depths and large surface areas), ammonia volatilization may be a significant removal mechanism for nitrogen, especially in warmer climates. Wastewater lagoon studies indicate that nitrogen losses up to 95% may occur under ideal conditions, with ammonia volatilization being the dominant mechanism (Reed, et al., 1995). However, research is needed to verify this mechanism in constructed wetlands. Microbial nitrification/denitrification as a nitrogen removal mechanism in VSBs and FWS wetlands is less likely, because of the predominance of anaerobic conditions. Nitrification of ammonia is unlikely to occur in VSBs and will occur in the FWS wetlands only if adequate open water zones are incorporated into the design (USEPA, 2000a).

Phosphorus removal in all types of constructed wetlands is primarily limited to adsorption to solids. The adsorbing solids may be material in the influent wastewater, which has been removed from the water column, plant detritus, or the soil or media in the wetland. All of these materials have a finite adsorption capacity, so phosphorus removal may occur for a time when a constructed wetland begins operation, but removal will decrease or stop as adsorption sites are filled. Long term phosphorus removal will be limited to phosphorus that adsorbs to new material entering the wetland that is buried before the phosphorus may be released back into the water column (Kadlec and Knight, 1996). Because new regulations will likely make phosphorus the limiting factor for land application of wastewater (USEPA, 2001), an additional unit process to remove phosphorus will be required.

7.5.4 Plant Functions

The role of aquatic plants in the treatment process is still not clearly understood but appears to be limited primarily to providing an attachment surface for microbes in FWS wetlands. While emergent

aquatic plants may provide oxygen from the atmosphere to their roots, field experience has shown that the small amount of oxygen that may “leak” from plant roots is insignificant compared to the organic and nitrification oxygen demands of heavily polluted wastewater applied at practical loading rates.

Nutrient utilization by plants is less than 20% of influent values for heavily polluted wastewaters (Reed, et al,1995) even if the plants are routinely harvested. If plants are not harvested, plant utilization is largely negated when the plants die in the fall and winter. Unless plant material containing nutrients is buried in the sediments before the nutrients leach out as the plants decompose, the nutrients will return to the water column.

Submerged aquatic plants in open water areas of FWS wetlands may supply oxygen to the wastewater during daylight hours. While they have been used in wetlands treating municipal wastewater, research is needed to determine their ability to tolerate heavily polluted CAFO wastewater. Floating aquatic plant systems (e.g. duckweed, water hyacinths, and algae) have been used to treat a variety of wastewaters. However, these systems require constant removal of plants and handling of the harvested material. While the harvested material may be processed and used as feed or land applied, very few operations using floating plants have succeeded in the U.S.

Researchers have hypothesized other plant functions in treatment wetlands. Plant detritus may provide carbon for microbial reactions and enzymes exuded by plant roots may enhance degradation of some organic compounds. Certain plant species may have symbiotic relationships with beneficial microbes attached to their roots, and these relationships could be useful for treatment purposes if they can be defined. Not enough research has been conducted to validate any of these functions.

7.5.5 Risk Associated with Constructed Wetlands

The use of constructed wetlands as a treatment technology carries some degree of risk for several reasons. First, although there is no evidence of harm to wildlife using constructed wetlands, some regulators have expressed concern about constructing a system that will treat wastewater while it attracts wildlife. Unfortunately, there has not been any significant research conducted on the risks to wildlife using constructed wetlands. Although they are a distinctly different type of habitat, lagoon treatment systems have not shown evidence of harm to wildlife. The fact that lagoon systems have been in use for many years suggests that there may not be a serious risk for wetlands treating agricultural wastewater. Of course, if a wetland is going to treat wastewater with high concentrations of known toxic compounds, the designer will need to use a VSB system or incorporate features in an FWS wetland that restrict access to wildlife.

Second, although many texts and design guidelines have been published for constructed wetlands in the past 10 years (Kadlec and Knight, 1996; Payne Engineering and CH2M-Hill, 1997; Reed, et al., 1998; USDA, 1991; USDA, 1995; USEPA, 2000a), questions remain about their application, design, and performance. Constructed wetlands are complex systems in terms of biology, hydraulics, and water chemistry. There is a lack of quality data of sufficient detail, both temporally and spatially, on full-scale constructed wetlands, forcing modelers and designers to derive design parameters by aggregating performance data from a variety of wetlands, which leads to uncertainties about the validity of the parameters. The design process is still empirical, that is, based upon observational data rather than scientific theories. Due to the variability of many factors at constructed wetlands that have been observed by researchers (e.g., climatic effects, influent wastewater characteristics, design configurations, construction techniques, operating parameters, and maintenance practices), there will continue to be disagreement about some design and performance issues for some period of time.

Third, there are several common misconceptions about constructed wetlands. Some people think that VSBs and FWS wetlands are aerobic systems, or at least have many aerobic microsites. As noted in the previous discussion of plants, this is not true. Another myth is that constructed wetlands remove large amounts of nutrients. As discussed previously, although some nutrient removal does occur, it is not at the high levels reported in some early research.

Finally, as noted in a review of constructed wetlands for wastewater treatment by Cole (1998), constructed wetlands are not uniformly accepted by all state regulators or EPA regions. Some authorities encourage the use of constructed wetlands as a proven treatment technology. Others still consider them to be an emerging technology due in part to concerns about the issues discussed above. As with any new treatment technology, uniform acceptance of constructed wetlands will take some time.

7.5.6 Application and Performance of Constructed Wetlands for Agricultural Wastewaters

Although an operation in Iowa has used a constructed wetland since the 1930's, constructed wetlands have been more commonly used to treat agricultural wastewaters in the United States for about 10 years. The USDA-NRCS issued guidance on constructed wetlands for agricultural wastewater treatment in 1991 (USDA, 1991). The U.S. EPA's Gulf of Mexico Program funded a project to assess the use of constructed wetlands for CAFO wastewater in the late 1990's (CH2M-Hill, 1997; Payne Engineering and CH2M-Hill, 1997; Knight, et al., 2000). The study depended primarily on data from a subset of the North American Treatment Wetland Database, v 2.0 (NADB) (USEPA, 1999) and summarized the performance of wetland systems (Table 7.3).

Table 7.3. Performance Data Summarized for Gulf of Mexico Program (CH2M-Hill, 1997)

Parameter	Influent (mg/L)	Effluent (mg/L)	Reduction (%)
BOD ₅	263	93	65
TSS	585	273	53
Ammonia	122	64	48
Total Nitrogen (TN)	254	148	42
Total Phosphorus (TP)	24	14	42

The entire NADB lists 135 wetland treatment systems at 69 sites that use constructed wetlands to treat agricultural wastewaters (Table 7.4).

Table 7.4. Agricultural Treatment Wetlands in the NADB

Animal Type	Wetland Type						Total Systems	Number of Sites
	Marsh			Open Water	Floating Plants	Other or Not Shown		
	FWS	VSB	Other					
Dairy	50	1		2	2	5	60	39
Swine	40		18				58	19
Cattle	5	2				2	9	8
Poultry	2			1		2	5	1
Aqua	3						3	2
Total	100	3	18	3	2	9	135	69

The wetlands are located in 18 states throughout the United States and in 5 Canadian provinces. A wide variety of plant species have been used, but cattails (*Typha*), grasses/reeds (e.g. *Phragmites*), and

sedges/rushes (e.g. bulrush (*Scirpus*)) were the predominant plants in 48%, 28%, and 14% of the systems, respectively. Floating plants, such as duckweed (*Lemna*), were predominant in 4% of the systems. The wetlands range from experimental systems at research farms to full-scale systems, so their size and costs vary greatly (Table 7.5). Because of the wide variation, the size and cost listed cannot be used for design purposes.

Table 7.5. Range of Costs and Operating Parameters for NADB Agricultural Treatment Wetlands

Parameter	Number*	Minimum	Maximum
Design Flow†	39	75 gpd	27,000 gpd
Area	127	43 sqft	116 ac
Area (per AU‡)	45	5 sqft/AU	6900 sqft/AU
Cost (per Area)	22	\$1645/acre	\$640,000/acre
Cost (per Flow)	13	\$0.73/gpd	\$174/gpd
Cost (per AU)	18	\$76/AU	\$6400/AU

*Number of systems in the NADB with data (out of the total of 135 systems)

†Actual flows were usually less

‡Animal Units

General treatment performance for several common wastewater parameters, shown as the 95% confidence interval about the mean, calculated from the NADB, is shown in Table 7.6. Because these are overall average values from all of the systems, regardless of size, flow or type of wastewater, the values shown cannot be used for design purposes. However, the numbers do give a general impression of the capabilities of constructed wetlands for treating CAFO wastewater. While it is obvious that effluent from these systems cannot be discharged to surface waters, the reductions are substantial and yield higher quality water for land application.

Table 7.6. 95% Confidence Interval about the Mean for all NADB Agricultural Treatment Wetlands

Parameter	Influent	Effluent	Removal
BOD ₅	246 - 352 mg/L	99 - 136 mg/L	34% - 44%
TSS	501 - 956 mg/L	360 - 676 mg/L	18% - 35%
Ammonia	141 - 174 mg/L	79 - 102 mg/L	23% - 31%
TP	24 - 29 mg/L	15 - 18 mg/L	15% - 31%
Dissolved Oxygen	2.1 - 2.7 mg/L	1.4 - 2.0 mg/L	
Fecal Coliform	2 x 10 ⁵ - 4 x 10 ⁵	2 x 10 ⁴ - 5 x 10 ⁴	0.8 - 1.0 log

Figure 7.9 shows a hog operation with a lagoon flowing into a constructed wetland. The treatment efficiency is reported to yield an effluent of higher quality than a nearby municipal wastewater treatment plant. Figure 7.10 shows a ground level view of the wetland with the owner making observations for his records.



Photo courtesy of USDA NRCS.

Figure 7.9. View of a hog operation with a lagoon flowing into constructed wetlands for treatment of wastewater.



Photo courtesy of USDA NRCS.

Figure 7.10. Ground level view of constructed wetland with the owner making observations for his records.

The USEPA currently has an agreement with the Tennessee Valley Authority to evaluate the use of its ReCip system at a swine operation in Alabama. The system treats wastewater from the anaerobic lagoon that receives the flush water from the swine buildings. The preliminary results from the first year of operation are shown in Table 7.7. As expected from a system with alternating aerobic and anaerobic

conditions, the ReCip systems had good BOD₅ and ammonia removal. Also as expected for any wetland system, phosphorus removal decreased from an initial 90% removal efficiency (< 10 mg/L in the effluent) to 20% removal (40 mg/L in the effluent) during the one year of operation.

Table 7.7. Preliminary Averages from ReCip System Treating Swine Wastewater

Parameter	Anaerobic Lagoon	ReCip Effluent	Removal
BOD	557 mg/L	108 mg/L	73%
Ammonia	371 mg/L	50 mg/L	86%
TP	51 mg/L	29 mg/L	43%
Fecal Coliforms			2 log ₁₀ units

7.5.7 Processes to Significantly Reduce Pathogens (PSRP)

Manure should be treated to effectively eliminate pathogens and applied appropriately to minimize the possibility of pathogen survival and subsequent crop contamination (IFT, 2002). An indication of the level of concern that World Health Organization (WHO), U.S. EPA, and the State of California place on the issue of proper application of recyclable materials to land is shown in Table 7.8 which presents microbiological quality guidelines and standards for the application of wastewaters to land. A PSRP is a technology that is broadly defined as one that reduces both the pathogen load and vector attraction in the environment (U.S. EPA, 1989). Typically, the pathogen reduction is a minimum of one order of magnitude.

Many factors may induce pathogen reduction occurring with various treatments such as temperature, storage length, and continuous addition of manure. Presently, facultative lagoons and composting are mostly used to manage waste at CAFOs. Likely, some pathogen reduction occurs, but it is difficult to quantify the amount. The methods that may be used in an animal feeding operation to treat manure and reduce pathogens include: composting; aerobic digestion, high temperature; anaerobic digestion at different temperatures; combinations of aerobic and anaerobic digestion; and long term storage of manure before land application.

7.5.8 Recommendation

Implement control technologies for treatment of animal waste to reduce pathogen loads prior to land application or off-site transfer. Based on review of the peer-reviewed scientific literature, and using best professional judgment, it is recommended to take steps now to reduce potential exposures to pathogens via this route. Several technologies have demonstrated the capability to significantly reduce the risk of pathogen contamination from land application of animal waste. The technologies also reduce the viability of *Cryptosporidium* oocysts, which have been found to be difficult to treat by publicly owned treatment works. These technologies are listed below.

7.5.8.1 Composting

Using either the within-vessel, static aerated pile or windrow-composting methods, the temperature of the animal wastes/manure is raised to 40°C (104°F) or higher and remains at 40°C (104°F) or higher for five days. For 4 hours during the 5-day period, the temperature in the compost pile exceeds 55°C (131°F) (U.S. EPA, 1989).

Table 7.8. Microbiological Quality Guidelines & Standards For Application Of Wastes To Land

Agency	Reuse Conditions	Helminths - No./100ml	Fecal Coliforms, No./100 ml	<i>Salmonella spp.</i> , No./100 ml	Enteric Viruses, No./100 ml
WHO	Crops likely to be eaten raw	≤ 1/L	≤ 1,000/100 ml	NR	NR
WHO	Pasture, fodder & industrial crops	≤ 1/L	NR	NR	NR
Blumenthal et al.	Crops likely to be eaten raw	≤ 0.1/L	≤ 1,000/100 ml	NR	NR
Blumenthal et al.	Spray irrigation of pasture, fodder and industrial crops	≤ 1/L	≤ 100,000/100 ml	NR	NR
USEPA	Unrestricted irrigation of municipal Class A sewage sludge	< 1 helminth ova/4g total solids (dry weight)	< 1,000/g total solids (dry weight)	< 3/4g total solids (dry weight)	< 1 PFU/4g total solids (dry weight)
USEPA	Application of municipal Class B sewage sludge	NR	< 2 x 10 ⁶ /g total solids (dry weight)	NR	NR
NC Admin Code	Land discharge of reclaimed domestic wastewater	NR	< 14/100 ml)	NR	NR
Calif. Code of Reg	Irrigation of food crops, high exposure landscapes	NR	< 2.2/100 ml ^b	NR	NR
Calif. Code of Reg.	Irrigation of dairy pastures, low-exposure landscapes	NR	< 23/100 ml ^b	NR	NR

(a) NR = No standard recommended

(b) Standard for fecal or total coliforms

7.5.8.2 Air Drying

Animal wastes/manure is dried on sand beds or on paved or unpaved basins. The animal wastes/manure dries for a minimum of three months. During 2 of the 3 months, the ambient average daily temperature is above 0°C (32°F).

7.5.8.3 Facultative lagoons / Storage

Animal waste/manure is treated or stored in a lagoon system at a temperature of ≤ 5°C for a period of at least six months or at a temperature of > 5°C for a period of at least four months. Since all wastes must be in a lagoon for the specified period, two lagoons will likely be needed such that while one is filling, the other may be aging. This avoids short-circuiting.

7.5.8.4 Anaerobic Digestion

Animal waste/manure is treated in the absence of air for a specific mean cell residence time (i.e., solids retention time) at a specific temperature. Values for the mean cell residence time and temperature must be between 15 days at 35°C (95°F) to 55°C (131°F) and 60 days at 20°C (68°F) (U.S. EPA, 1989).

7.5.8.5 Aerobic Digestion

Animal waste/manure is agitated with air or oxygen to maintain aerobic conditions for a specific mean cell residence time (i.e., solids retention time) at a specific temperature. Values for the mean cell residence time and temperature must be between 40 days at 20°C (68°F) and 60 days at 15°C (59°F) (U.S. EPA, 1989).

7.5.8.6 Lime Stabilization

Sufficient lime is added to the animal waste/manure to raise its pH to 12 for ≥ two hours of contact. *More detailed information on Technologies 1, 2, 4, 5, and 6 in *Environmental Regulations and Technology: Control of Pathogens and Vector Attraction in Sewage Sludge (EPA/625/R-92/013 – 1999 Edition.)*

Table 7.9 shows technologies for potential use at CAFOs and their expected effect on pathogen levels (USEPA, 2001).

Table 7.9. Effects of waste treatment and management systems on pathogen reductions.¹

Treatment Process	Maximum Reduction (%) ²	Animal Waste	Comments
Liquid Systems			
Anaerobic lagoons	99.0% per cell	swine, dairy, beef, layers	residence time of months
Aerated lagoons	99.0% per cell	swine, dairy, beef	residence time of months
Anaerobic thermophilic digesters	99.9%	swine, dairy, beef	Temperature- dependent
Anaerobic mesophilic digesters	99.0%	swine, dairy, beef	
Constructed wetlands	99.0% per cell	swine, dairy, beef	Do not work well with high solids content, temperature-dependent
Overland flow	50.0%	swine, dairy, beef	Temperature-dependent
Solids Separation			
Aerobic (liquid fraction)	99.0%	swine, dairy, beef	
Chemical (liquid fraction)	99.0%	swine, dairy, beef	Time-dependent
Alkaline treatment (liquid or dry)	99.9%	most	Time-dependent
Thermal Process			
55-60° C	99.9%	most	Time- and temperature - dependent
> 60° C	99.9%	most	Time- and temperature- dependent
Composting	99.9%	most	Time- and temperature- dependent, need mixing for aeration

¹Summary from USDA/EPA “Workshop on Emerging Infectious Disease Agents and Issues Associated with Animal Manures, Biosolids, and Other Similar Byproducts” June 4-6, 2001 Cincinnati, OH. (Reference in bibliography section)

²Maximum pathogen reductions converted from log₁₀ reductions (1 log₁₀ reduction = 90.0%, 2 log₁₀ reduction = 99.0%, 3 log₁₀ reduction = 99.9%).

Most technologies currently or likely to be used by CAFOs reduce pathogen levels up to 99%. Several factors may impair the pathogen reduction obtained with these technologies. Most of these technologies are time-dependent (some requiring months of residence time) and pathogen reduction may be lower with reduced residence time. Some of these technologies operate under conditions of continuous addition of manure, which may impede pathogen reduction. Some of the technologies like constructed wetlands and composting operate optimally under specific solids level ranges (percentage) and could have poor pathogen reductions outside those optimums. Several of these technologies (anaerobic thermophilic

digesters, constructed wetlands, and thermal processes) operate optimally under specific temperature ranges and could have impaired pathogen reductions outside those optimums.

7.6 Land reclamation

7.6.1 Non-Farm Land Applications

In large parts of the United States areas exist where untreated or semi-treated manures may be land-applied with little risk of pathogens reaching human receptors directly. These areas will allow aerobic degradation and provide a use for carbon and nitrogen in the materials. The needed research builds on the information learned from farm applications of feedlot waste, and extends it to new markets for the material. The main limitations to current off-site use of these materials are lack of information about the effects and economics of transportation.

There are two categories of non-farm land applications of CAFO wastes: on-site and off-site. On-site application could include CAFO controlled forest plots and wetlands, or perhaps a combination of trees, cropland, and wetland. Feed lot wastes could possibly be safely used on off-site applications, various land reclamation projects, forest crops, and on vegetation in uninhabited areas such as along highways.

Hard rock and coal mines have left sterile scars across thousands of square miles of landscapes in this country's mining regions, frequently covering topsoil layers with infertile subsoil, rock, and mine tailings. These are unsightly, have no habitat value, and often acidify rainwater causing downstream damage. Restoring these sites requires carefully reconstructing the conditions for pedogenesis, or soil creation. Organic material must be incorporated to establish vegetation, and annual or more frequent applications may aid in ensuring successful establishment of the conditions for sustainable vegetation. Similarly, restoration of coal mine sites may benefit from application of lime and organic material in the form of animal waste. Heavily eroded lands may also benefit from application of manure combined with dredge spoil as a step towards recreation of the soil surface.

7.6.2 Phytoremediation Projects, Sediment Recycling, and Landfill Covers

Small sites, ranging in the tens of acres, exist across the United States in locations that could potentially accommodate applications of CAFO materials several times per year. These sites are typically secure from casual human intrusion, and the plants grown on them are not consumed by people nor by livestock. Generally these sites pay for fertilizer and organic material, especially during initial installation, which could offset some transportation costs.

7.6.3 Riparian Corridors

Riparian corridors are stream bank and riverside strips of trees and other vegetation that separate agricultural fields from surface water and protect that water by filtering, degrading, and using excess fertilizer, herbicide, and pesticide. This run-off prevention system may be extremely effective both at improving stream cleanliness and at providing enhanced habitat for both terrestrial and aquatic species. Thousands of miles of riparian corridors have been planted and are continuing to be planted around the Chesapeake Bay and along the Mississippi watershed.

7.6.4 Forest Products: Short Rotation Wood Crops- Pulp & Paper, Lumber, Fuel

The wood products industry plants tens of thousands of acres of fast growing hybrid trees each year. These trees thrive on high nutrient levels. Regular applications of feedlot waste might be an ideal use if the

transportation and safety considerations may be satisfactorily explored. Forest application of treated sewage sludge has been researched, and that work might be applicable to some extent.

7.6.5 Highways: Roadsides and Medians

The thousands of miles of grassy medians and roadsides present an opportunity for beneficial disposal of CAFO materials. Regular, thin applications of liquid or solid material could provide a safe area for aerobic degradation, distant from human contact, on plants not intended for livestock consumption.

Each of these areas has needs and concerns that should be researched before application. There should be an estimate of how many acres or square miles are available of each type of terrain in various geographic regions. Different regions have different usage opportunities; for example, Appalachia and the Rocky Mountains need organic material for hard rock mine reclamation, while the Great Lakes area have dredged sediments that need organic materials to encourage contaminant degradation and plant growth in order to turn dredged material into soil suitable for beneficial reuse.

Finally the loading rate limitation for each terrain and application needs to be determined. The quantity of waste that may be safely applied to a particular project depends on the form of the waste (solid or liquid), the nutrient and chemical load of the material, and the capacity of the application to hold and utilize the material. That capacity is, in turn, based on equipment limitations, nutrient use capacity of the particular vegetation, seasonal access to sites, and climate considerations. Each use would require research and experimentation to determine the type of equipment that would be needed for application in the target terrain.

A protocol that outlines how to match resources (waste sources) with utilizers within an economical travel distance would be extremely useful. Such a guide would help local feedlot farmers, foresters, ecological restorers and others answer those questions that prevent the synergies that allow use of this material as a resource.

8 Research Needs Associated with CAFOs

8.1 Overview

Identified research needs related to CAFO issues fall into several categories. The categories are interactive and mutually supporting. One category is stressor evaluation and quantification. A second category is method development; new methods are needed to rapidly and inexpensively measure stressor levels. New methods are also needed to identify sources of stressors in the environment. A third research category encompasses process research. Process research will involve several levels of work from bench-scale to field-scale. How may waste treatment systems be optimized for control of different stressors? How may they be made cost effective? Can salable products be generated from waste streams? Different stressors will have to be addressed individually and in combination. The fourth category of research needs relates to stressors in the environment. Fate and effects of specific stressors must be elucidated. Management practice effects on stressors must be studied. Transport of stressors in different media from sources to receptors must be understood. Other topics of research that are presented in more detail are ground water research, aerosol research, and land reclamation.

8.2 Stressor Evaluation and Quantification

The first two research categories are closely related. Stressor evaluation and quantification is a fundamental need in identifying problem areas. Current methods are quite good for measuring nutrient levels in various media. Methods for sediments in water are also good. Source identification for nutrients is more of a problem. In some cases, isotope analysis of C, N, and P could lead to identification of sources of stressors. Much work needs to be done to make isotope methods more readily applicable. Quantitative analysis of antibiotics, EDCs, and pathogenic microorganisms in waters, soils, sediments, and manures is needed to evaluate stressor content and movement. Rapid, precise methods need to be developed for analysis of these stressors in the different matrices. Methods for analysis of EDCs and antibiotics in different matrices will ultimately rely on GC-MS and HPLC-MS for quantification. Analysis of pathogenic organisms will require a completely new approach. Currently, fecal coliforms (FC) and fecal streptococci (FS) are used as indicators of fecal pollution. There may easily be cases where pathogenic organisms may exist with no associated FC or FS. The best approach requires developing methods that may be applied to water, soil, sediment, or manure to directly detect and quantify specific pathogens.

The organisms most commonly implicated in human illness should be included in the test method. Among the organisms of concern are *E. coli* O157:H7, *Salmonella* spp., *Campylobacter jejuni*, *Listeria monocytogenes*, *Leptospirillum* spp., *Cryptosporidium parvum*, and *Giardia lamblia*. These bacterial pathogens are perhaps the most readily detected and most commonly implicated in causing health problems. With the advent of genetic analysis methods, it is possible to develop means to specifically identify organisms and track them to their source. Work has been done on source identification with some organisms in agricultural areas of Oregon and California. Protozoan parasite detection and enumeration is much more difficult. Currently, the methods require large sample volumes, are laborious, and require highly skilled analysts. Development of rapid methods for identification and enumeration of protozoan parasites is highly desirable.

Associated with the need for microbiological methods is the need to determine the survival of known pathogens under different conditions. Treatment or storage of manures should have effects on microbial populations. These effects should be determined to establish the utility of different treatment systems for reducing pathogen loads. Detection and enumeration methods for the different organisms are required to

address this need. Compilation of a database of microbiological information is needed to assess and track epidemiological information related to pathogens in animal waste. Little of this information is readily available. Similarly, the database should include animal disease epidemiological data as well. Existing literature on baseline mortality of animals needs to be compiled as well. The potential financial loss from an outbreak of animal pathogens is on the order of several billion dollars.

8.3 Process Research

The third major category of research needed to address the environmental challenges of CAFOs is process research. Process research entails examination of waste handling in the different sectors of agriculture. Different treatment processes are effective in controlling different stressors. Waste treatment processes with potential application to animal waste include lagoon storage and lagoon modification, aerobic digestion, anaerobic digestion, staged aerobic/anaerobic digestion, thermophilic digestion, composting, and lime treatment. Much work is needed to optimize these systems for controlling the different stressors. Conditions of treatment that control nutrients may have little effect on pathogen survival or may even encourage regrowth.

Stabilization of nutrients by alum is a new area of research. The use of alum on poultry litter has shown greater promise in stabilizing P to prevent its runoff to surface waters and leaching to ground waters. Alum also stabilizes ammonia, making poultry litter more valuable as a fertilizer. Conditions that control pathogenic organisms may have little effect on nutrients. The different systems must be optimized for waste type, stressor reduction and cost.

Another aspect for cost control is configuring treatment systems to generate salable products. Anaerobic systems offer the possibility of CH₄ production. Some processes may recover fertilizer elements in condensed forms that are more readily salable. Methane may potentially provide energy for operation on the farm. As a lower cost alternative, composting is a useful treatment alternative. Establishing performance characteristics for different animal wastes and effects on different stressors is an important goal. Performance of poorly practiced composting must be established with regard to stressor control. While the major effort will focus on systems for larger CAFOs, the smaller producer should have alternatives for waste handling available. Smaller systems should be developed to address the same problems for the smaller producer. A complete systems approach will be needed to optimize nutrient control, pathogen control, and value recovery.

8.4 Fate and Effects of Stressors in the Environment

The fate and effects of stressors in the environment and the transport of those stressors in the environment generate questions that are difficult to answer. Land application is a major practice for the disposal of animal wastes from large and small facilities. The effectiveness of buffer strips with different types of vegetation, width, and interaction with other soil management procedures should be evaluated. Related to land application is the control of sediment generation from application sites and CAFO facilities themselves. Study of engineered structures to collect sediments and management techniques is needed with regard to other stressors that may move with sediments. Sediments offer attachment sites for nutrients, EDCs, and pathogens. How effective is reducing sediment movement in reducing other stressor movement into waterways?

Another water management tool proposed to be useful in waste management is the constructed wetland. How do constructed wetlands perform over long term use under different climatic conditions?

Are they efficient in solid/liquid separation? What functions do different aquatic plants carry out? How are they best monitored for performance? Do they function to remove excess phosphorus? What air emissions may be expected from different types of wetlands?

8.5 Ground Water

Future research related to CAFO impact on ground water may be categorized into the following broad areas: 1) transport and fate; 2) hydrogeology; 3) testing and monitoring; 4) risk management; 5) prevention; 6) predictive modeling; and 7) impact of CAFOs on ground water resources. Improved knowledge of the major factors affecting nutrient transformation, transport, and reactions in ground water is an area that requires attention by soil/environmental scientists, hydrologists, hydrogeologists, and environmental engineers. Research is needed to understand the fate of nitrogen under aerobic and anaerobic conditions (nitrate, ammonium, organic-nitrogen) in stream riparian buffers, wetlands, and hyporheic zones (i.e., groundwater-surface water interface). Transport of nitrate by preferential flow from treated soil/storage ponds to ground water and/or tile drains is a critical area of research. Research documenting phosphorus losses from soil receiving manure via subsurface tile drainage is limited. Leaching of solutes below earthen waste ponds/lagoons to deep ground water, where the primary mode of transport to ground water is unsaturated flow, warrants further research. The mechanism of self-sealing, particularly the effect of wetting/drying cycles on reducing the extent of sealing in lagoons is an area that needs further research. A method needs to be developed to account for sealing effects and related factors, such as temperature, waste characteristics, soil structure and texture, pond depth, and frequency of pump down.

The survivability and transport of manure pathogens in soil and aquifers is not well characterized, especially transport mechanisms for *Cryptosporidium* oocysts in the subsurface. More studies and information are needed on their movement in soils. Studies are needed to investigate the impact of periodic freezing-thawing -- a common phenomenon during United Kingdom winters particularly in upland sheep-farming areas (ref?). Little research has focused on the role of plant roots and micro- and mesofauna in the translocation of pathogens. The importance of preferential transport of microorganisms by macropores from treated soils and/or leachate from earthen storage ponds warrants future research. Further investigation is needed into the effectiveness of riparian buffers and wetlands for removal of pathogens from subsurface water. Improved fundamental understanding of sorption/desorption characteristics and die-off rates of microorganisms in different soils and aquifer sediments is essential in designing for and evaluating the efficacy of alternative mitigating measures.

Continued research on fundamental understanding of movement of ground water (hydrogeology) in unsaturated soil (vadose zone hydrology) is a major prerequisite for studying source and prevention issues. Research is warranted to investigate seepage losses from storage pond side slopes subject to frequent water level fluctuations. Technology is needed for measuring infiltration for low permeability soils. Further research is warranted to compare evaporation from clear water and animal wastewater, which may affect water balance in ponds and thus seepage losses.

Standardized methods are needed that may relate P quantity and intensity factors to desorption and downward movement of P and thus to the potential for P loss in subsurface runoff; i.e., soil tests for predicting potential for P loss in leaching and drainage waters. Soil monitoring methods to accurately track nutrient leaching in soil to ground water warrants further research.

Operational research (e.g., systems analysis and optimization) and modeling are important research areas, especially for risk management at the watershed scale. Because of uncertainty in seepage rates and

other environmental factors, effort should be directed toward the development of stochastic, risk-based approaches for the design and performance evaluation of detention ponds/lagoons. Developing a reliable, risk-based regulatory system that would be acceptable to regulators, operators, and the general public is a future research need. Developing predictive models based on sound scientific principles for assessing the impact of CAFOs on ground water and for risk-management in watersheds is an area of future research.

Preventing pollutants derived from animal waste from reaching ground water may result in substantially reduced costs, otherwise incurred with treatment or removal of pollutants in drinking water. This would require developing appropriate management practices for animal waste to reduce potential groundwater pollution, e.g., by nitrate and pathogens. Methods need to be developed to evaluate the impact of animal waste management practices at the individual, local level and at the integrated, watershed level.

Models are useful tools to identify sources and to estimate the relative loading of pollutants from various management scenarios. Their role is best realized in complementing and not replacing environmental monitoring. Rather than relying on costly intensive monitoring, simulation models may aid in the development of cost-effective and optimal monitoring network. More effort is needed for modeling pathogen transport and fate in the soil and groundwater. Models need to be revised to account for the complex interactions governing movement of microorganisms and other pollutants in soils as well as in micropores. Incorporating a macropore flow component may improve the performance of models to predict the fate of injected animal manure. Because of uncertainty in seepage rates and factors governing movement of pollutants (e.g., pathogens, nutrients, and salts), probabilistic/stochastic-based modeling approaches will be needed for risk-based planning and decision making.

Evaluating the performance of alternative abatement measures will benefit from improving the capability of current watershed models to simulate the capacity of riparian buffers, vegetative filtering strips, detention reservoirs, natural/constructed wetlands, and tillage practices to reduce the impact of manure from agriculture and runoff from storage facilities on water quality. Developing modeling systems that integrate processes across watersheds (both surface and groundwater) warrants further research. Integrating modeling technology with systems analysis will be needed for optimal selection of alternative abatement strategies.

Future research may be needed to address the following institutional questions: At what level is risk management conducted (individual home, farm, or community)? What strategies are used to control groundwater contamination? How do we make decisions on whether to do community treatment versus point-of-use treatment versus development of new water resources? Research is required to emphasize the need to forge a working relationship among scientists, regulatory agencies, and stakeholders to develop BMPs that are both environmentally sound and feasible in the short and long terms. Research is warranted on the impact of socio-economic and political constraints on environmentally effective decision-making.

8.6 Aerosol Research

Aerosol issues form another field of work in the handling of CAFO waste. Often, the first environmental impact of a CAFO is the odor generated by the animal waste. With the concentration of large numbers of animals in smaller areas the potential for odor generation is high. The public may perceive problems in such areas if the odors generated are irritating. Production of particulates from CAFOs is a concern because the particulates may easily fall into the regulated size classes of PM_{2.5} or PM₁₀. PM_{2.5} particles are respirable deep into the lung and may be a source of irritation or infection. Do particulates carry intact microbial cells, endotoxins, and allergens? Can they be detected? Are there species-specific

aerosol patterns related to housing types and waste system types? Can housing systems be designed to minimize particle generation? Odor impacts are largely subjective and difficult to measure objectively. Can a classification system be created to make objective measures of odor problems? The system must be able to identify and quantify odors with regard to duration, intensity, frequency and offensiveness. Are there good emission rate models for ammonia, H₂S, VOCs, and particulates? Are there ways to reduce emissions?

Ammonia falls into more than one group of problems because it has a strong odor, is a nutrient, and may attach to particles. Volatile organic compounds also contribute to odor problems. Many of these compounds are contained in manure and are created by microbial action during storage or digestion of the manure. Can the processes used for waste handling be modified to reduce odor generating organic compounds? Staged treatment processes may be able to reduce odor compounds concurrent with treating the waste for other stressors. Would a biofilter be able to reduce odor compounds sufficiently to reduce the impact of odors?

8.7 Land Reclamation

Reclamation of disturbed land is another possible use for animal waste. Many areas of the United States have large tracts of land seriously disturbed by many causes. Strip-mined land, mine spoil banks, seriously burned-over land, and new highway construction may create highly disturbed land. Much of the soil replaced or exposed in these areas has little protection from further degradation from erosion and supports poor plant growth. A potential use of animal manure is to create new soils by mixing manures with excavated dredge spoil from waterways and application of the material to unproductive land. The manure contributes organic matter and nutrients to the soil. Manure also conditions the soil to be more friable and hold more water for plant growth. The amount of available land in different classes and the quantity of manufactured soil that could be applied at one time must be determined. Another use for manufactured soil is restoration of heavily eroded soil in the United States. Return of soil material to areas that have experienced losses of topsoil could be a beneficial use of manure composted together with freshwater dredge material from the large river systems in the United States. The U. S. Army Corps of Engineers moves about 100 million tons of dredge material every year. Some of this material could be composted together with manure to make a product that could replace eroded soils.

9 REFERENCES

- Agriculture and Agri-Food Canada. 1998. Hog Environmental Management Strategy/Situation Analysis/Chapter 2/Environmental Issues. ManureNet/Hog Environmental Management Strategy Steering Committee. pp. 1-5. Web Site:http://res2.agr.ca/initiatives/manurenet/en/hems/sit_anal_ch2.html.
- AGSTAR Digest. 2003. Office of Air and Radiation, United States Environmental Protection Agency, Washington, D.C. EPA-430-F-02-028.
- Alonso, M. Lopez, 2000. The Effect of Pig Farming on Copper and Zinc Accumulation in Cattle in Galicia (North-Western Spain). *The Veterinary Journal*. 160:259-266.
- Al-Masri, M.R., "Changes in Biogas Production Due to Different Ratios of Some Animal and Agricultural Wastes," *Bioresource Technology*, Vol. 77, Issue 1, March 2001, pp. 97-100.
- Altekruse, S.F., M.L. Cohen, and D.L. Swerdlow. 1997. Emerging foodborne diseases. *Emerg. Infect. Dis.* 3(3):285-293.
- ASAE 1999. "Manure production and characteristics." AS Data: AS D384.1. American Society of Agricultural Engineers, St. Joseph, Michigan
- Atherton, F.C., Newman, P.S. et al 1995. An outbreak of waterborne cryptosporidiosis associated with a public water supply in the UK. *Epidemiol. Infect.* 115:123-131.
- Banton, Marcy I., et al.1987. Copper toxicosis in cattle fed chicken litter. *JAVMA*, 191:827-828.
- Barker, James C., "Lagoon Design and Management for Livestock Waste Treatment and Storage," North Carolina Cooperative Extension Service, Water Quality & Waste Management, March, 1996. <http://www.baencsu.edu/programs/extension/publicat/wqwm/ebae103-83.html>
- Baseline Reference of Feedlot Health and Health Management. Part II. 1999. USDA APHIS. Veterinary Services. Centers for Epidemiology and Animal Health. 555 South Howes St. Ft. Collins, CO 80521.
- Baseline Reference of Feedlot Management Practices. Part I 1999. USDA APHIS. Veterinary Services. Centers for Epidemiology and Animal Health. 555 South Howes St. Ft. Collins, CO 80521.
- Baxter-Potter, W.R., and M.W. Gilliland, 1988. Bacterial pollution in runoff from agricultural lands. *J. Environ. Qual.* 17:27-33.
- Behm, Don (2), Date unknown, Ill Waters: The Fouling of Wisconsin's Lakes and Streams, *The Milwaukee Journal*, Milwaukee, Wisconsin.
- Behrends, L.L., F.J. Sikora, H.S. Coonrod, E. Bailey, and M.J. Bulls. 1996. Reciprocating Subsurface-flow Wetlands for Removing Ammonia, Nitrate, and Chemical Oxygen Demand: Potential for Treating Domestic, Industrial and Agricultural Wastewater. Proceedings Water Environment Federation, 69th Annual Conference, Dallas, TX, October 5-9, 1996. Vol. 5, pp. 215-263.

Bertoldi, M., Zucconi, F. and Civilini, M. 1988. Temperature, pathogen control and product quality. *Biocycle*. Feb. 43-50.

Bicudo, José R., "Frequently Asked Questions about Aerobic Treatment," University of Minnesota Extension Program, Biosystems and Agricultural Engineering.
<http://www.bae.umn.edu/extens/faq/aerobicfaq.html>. March 23, 2001.

Bitzer, C.C. and J.T. Sims. 1988. Estimating the availability of nitrogen in poultry manure through laboratory and field studies. *J. Environ. Qual.* 17: 47-54.

Blumenthal, U.J., Mara, D.D., Peasey, A., Ruiz-Palacios, G. and Stott, R. Guidelines for the microbiological quality of treated wastewater used in agriculture: recommendations for revising WHO guidelines, *Bull. WHO*, 78, 1104, 2000.

Böhlke, J. K., and J. M. Denver. 1995. "Combined use of groundwater dating, chemical, and isotopic analyses to resolve the history and fate of nitrate contamination in two agricultural watersheds, Atlantic coastal plain, Maryland." *Water Resour. Res.*, 31, 2319-2339.

Bosch, D.J. and K.B. Napit. 1992. Economics of transporting poultry litter to achieve more effective use as a fertilizer. *J. Soil Water Cons.* 47:342-346.

Brackett, R.E. 1999. Incidence and behavior of *Listeria monocytogenes* in products of plant origin. Pp. 631-655. In E. T. Ryser and E. H. Marth (ed.). *Listeria*, listeriosis, and food safety. Marcel Dekker Inc., New York.

Burge, W.D., Miller, P.D. Enkiri, N.K. and Hussong, D. 1987. Regrowth of salmonella in composted sewage sludge. EPA/600/S2-86/106.

California (State of). Wastewater reclamation criteria. California Code of Regulations, Title 22, Division 4, Environmental Health, 1978.

Carne, S. R., P. W. Westerman, and M. R. Overcash. 1980. "Die-off of fecal organisms following land application of poultry manure." *J. Environ. Qual.*, 9, 531-.

Chaney, Rufus, 2002. USDA. Telephone conversation with S. J. Stoll, 11/08/02.

Chaney, Rufus, 2000. Correspondence from R. Chaney to R. Alexander and participants in the Composting Discussion, 2/5/00, www.mailman.cloudnet.com/pipermail/compost/2000-February/000765.html.

CH2M-Hill. 1997. Constructed Wetlands and Wastewater Management for Confined Animal Feeding Operation. Pamphlet published by CH2M-Hill. (Available from Gulf of Mexico Program Public Information Center, Stennis Space Center, MS, 601-688-7940.)

Choi K. 1999. Optimal operating parameters in the composting of swine manure with wastepaper. *J-Environ-Sci-Health,-Part-B,-Pestic-Food-Contam-Agric-Wastes* 34, no. 6: 975-87.

- Christie, P. and Beattie, J. A.M., 1989. Grassland soil microbial biomass and accumulation of potentially toxic metals from long-term slurry application. *J. Applied Ecology*. 26:597-612.
- Christen, K. 2001. Chickens, manure, and arsenic. *Environmental Science & Technology*, May 1, 2001.
- Cieslak, Paul R., K.F. Gensheimer, et al., 1993. *Escherichia coli* 0157:H7 Infection from a Manured Garden, *The Lancet* 1993; 342:367.
- Ciravolo, T. G., D. C. Martins, D. L. Hallock, E. R. Collins Jr., E. T. Kornegay, and H. R. Thomas. 1979. "Pollutant movement to shallow groundwater tables from anaerobic swine waste lagoons." *J. Environ. Qual.*, 8(1), 126-130.
- Clausen, J. C., K. Guillard, C. M. Sigmund, and K. M. Dors. 2000. "Water quality changes from riparian buffer restoration in Connecticut." *J. Environ. Qual.*, 29(6), 1751-1761.
- Cole, D.J., Hill, V.R., Humenik, F.J. and Sobsey, M.D. Health, safety, and environmental concerns of farm animal waste, *Occupational Medicine: State of the Art Reviews*, 14, 423, 1999.
- Compost Science and Utilization. 1993; 1 (2) 65-72.
- Cook, M.G., P.G. Hunt, K.C. Stone, and J. H. Canterbury. 1996. Reducing diffuse pollution through implementation of agricultural best management practices: a case study. *Water Sci. Technol.* 33:191-196.
- Copeland, Claudia, and Zinn, Jeffrey, "Animal Waste Management and the Environment: Background for Current Issues," National Council for Science and the Environment, CRS Issue Brief for Congress, Washington, D.C., May, 1998
- Cord-Ruwisch, Ralph, "Waste Not Too Hard to Digest," Murdoch News Article. wwwcomm.murdoch.edu.au/webster/A57.html.
- Crandall, Christy A. 1999. "Distribution and fate of nitrate in shallow ground water of citrus farming areas, Indian River, Martin, and St. Lucie Counties, Florida," in *Effects of Animal Feeding Operations on Water Resources and the Environment*. Proceedings of the technical meetings, Fort Collins, Colorado, Aug. 30-Sep. 1. US Geological Survey Open File Report 00-24.
- Culley, J.L.B. and P.A. Phillips. 1982. Bacterial quality of surface and subsurface runoff from manured sandy clay loam soil. *J. Environ. Qual.* 11:155-158.
- Dalzell, H.W., A.J. Biddlestone, K.R. Gray, and K. Thuraijan. 1987. Soil Management: Compost production and use tropical and subtropical environments. FAO Soils Bulletin 56, Food and Agriculture Organization of the United Nations, Rome.
- Dean, D. M., and M. E. Foran. 1992. "The effect of farm liquid waste application on tile drainage." *J. Soil Water Conserv.*, 47, 368-369.
- De Lange, C. F. M., 2002. Effects of feeding strategy on growing-finishing pig performance and nutrient excretion. Midwest Nutrition Conference. Sept. 4, 2002. Indianapolis, IA, USA.

- De Lange, C. F. M. 1997. "Dietary Means to Reduce the Contributions of Pigs to Environmental Pollution" From Proceedings of Swine Production and the Environment Seminar "Living With Your Neighbours", March 26, 1997, Shakespeare, Ontario.
- Deluca, T. H., and D. K. Deluca. 1997. "Composting for feedlot manure management and soil quality." *J. prod. Agric.*, 10(2), 189-190.
- Devito, K. J., D. Fitzgerald, A. R. Hill, and R. Aravena. 2000. "Nitrate dynamics in relation to lithology and hydrologic flow path in a river riparian zone." *J. Environ. Qual.* 29, 1075-1084.
- Dillaha, T.A., J.H. Sherrod, D. Lee, V.O. Shanholtz, S. Mostaghimi, and W.L. Magette. 1986. Use of vegetative filter strips to minimize sediment and phosphorus losses from feedlots: phase 1. experimental plot studies. VPI-VWRRC-Bull 151. Virginia Water Res. Res. Center. VPI, Blacksburg, VA.
- Doran, J.W. and D.M. Linn. 1979. Bacteriological quality of runoff from pastureland. *Appl. Environ. Microbiol.* 37:985-991.
- Dougherty, M., editor. 1999. Field guide to on-farm composting., NRAES-114. Ithaca, N.Y: NRAES.
- Dougherty, M., L.D. Geohring, and P. Wright. 1998. Liquid manure application systems design manual. Northeast regional agricultural engineering service. Ithaca, NY
- Edwards, D.R. and T.C. Daniel. 1992. Environmental impacts of on-farm poultry waste disposal-a review. *Bioresource Technol.* 41:9-33.
- Eghball, B. 2000. Nitrogen mineralization from field-applied beef cattle feedlot manure or compost. *Soil Sci. Soc. Am. J.* 64:2024-2030.
- Eneji, A. E., Honna, T., and Yamamoto, S., 2001. Manuring effect on rice grain yield and extractable trace elements in soils. *J. of Plant Nutrition.* 24:967-977.
- Entry, J.A. and N. Farmer. 2001. Movement of coliform bacteria and nutrients in groundwater flowing through basalt and sand aquifers. *J. Environ. Qual.* 30:1533-1539.
- Epstein, E. 1993. Neighborhood and worker protection for composting facilities: issues and actions. p. 319-338. *In* H.A.J. Hoitink and H.M. Keener (ed) *Science and Engineering of Composting: Design, Environmental, Microbiological and Utilization Aspects.* Renaissance Publ., Worthington, OH.
- Evans, R.O., P.W. Westerman, and M.R. Overcash. 1984. Subsurface drainage water quality from land application of swine lagoon effluent. *Trans. Amer. Soc. Agric. Eng.* 27:473-480.
- Fernandes, L., and M. Sartaj. 1997. Comparative study of static pile composting using natural, forced and passive aeration methods. *Compost-Science-and-Utilization* 5, no. 4: 65-77.

- Finstein, M.S., and Hogan, J.A. 1993. Integration of composting process microbiology, facility structure and decision-making. p. 1-23. *In* H.A.J. Hoitink and H.M. Keener (ed) *Science and Engineering of Composting: Design, Environmental, Microbiological and Utilization Aspects*. Renaissance Publ., Worthington, OH.
- Flynn, R. P., and C. W. Wood. 1996. Temperature and chemical changes during composting of broiler litter. *Compost-Science-and-Utilization* 4, no. 3: 62-70.
- Follet, Ronald F. September 1995. "Fate and transport of nutrients: Nitrogen." *Working Paper No. 7*, U. S. Department of Agriculture, Agricultural Research Services, Soil-Plant-Nutrient Research Unit, Fort Collins, Colorado.
- Frarey, L., L. Hauck, R. Jones, and N. Easterling. 1994. "Livestock and the environment: Watershed solutions." *Texas Institute for Applied Environmental Research (TIAER)*. Tarleton State University, Stephenville, Texas.
- Fukushima, H., Hashizume, T., et al. Clinical experiences in Sakai City Hospital during the massive outbreak of enterohemorrhagic *E. coli* O157:H7 infection in Sakai City, Japan 1996. *Pediatrics International* 41:213-217. 1999.
- Gagliardi, J.V. and J.S. Kerns. 2000. Leaching of *Escherichia coli* O157:H7 in diverse soils under various agricultural management practices. *Appl. Environ. Microbiol.* 66:877-883.
- Gangbazo, G., A.R. Pesent, G.M. Barnwett, J.P. Charuest, and D. Cluis. 1995. Water contamination by ammonium nitrogen following the spreading of hog manure and mineral fertilizer. *J. Environ. Qual.* 24:420-425.
- Geldreich, E.E., Fox, K.R., et al 1992. Searching for a water supply connection in the Cabool, Missouri Disease Outbreak of *E. coli* O157:H7. *Water Research* 26:1127-1137.
- Geohring, L. D., P. E. Wright, T. S. Steenhuis, and M. F. Walter. 1999. "Fecal coliforms in tile drainage effluent." *ASAE Paper No. 99-2203*, St. Joseph, MI.
- Gerritse, R. G. 1977. "Phosphorus compounds in pig slurry and their retention in the soil. *In: Utilization of Manure by Land Spreading, Commission European Commun., London*. Cited in U.S.EPA (1998)
- Gettier, S. W., Martens, D. C., E. T. Kornegay, 1988. Corn response to six annual Cu-enriched pig manure applications to three soils. *Water, Air, and Soil Pollution.* 40:409-418.
- Giddens, J. and A.P. Barnett. 1980. Soil loss and microbiological quality of runoff from land treated with poultry litter. *J. Environ. Qual.* 9:518-520.
- Gilley, J.E. and B. Eghball. 1998. Runoff and erosion following field application of beef cattle manure and compost. *Trans. Am. Soc. Agric. Eng.* 41:1289-1294.
- Goodrich, Phillip, R., "Creating Fuel from Manure is a Hot Topic – Again," Minnesota/Wisconsin Engineering Notes. <http://www.bae.umn.edu/extens/ennotes/enspr01/fuel.htm>, May 2001.

Gordeiko VA, Pushkareva VI.(1990) [Yersinia in the water of wells near an area of irrigation with the effluents from a swine-breeding farm complex] [Article in Russian] Zh Mikrobiol Epidemiol Immunobiol 1990 Oct; (10):65-6

Grey, M. and Henry, C. 1999. Nutrient retention and release characteristics from municipal solid waste compost. *Compost Science and Utilization*. 7(1)42-50.

Hallberg, G. R. 1987. "A Primer on groundwater and groundwater contamination." In *Chautauqua Groundwater Workshop for Extension Agents*, Chautauqua Institution, Chautauqua, New York, May 7-9, 1986, Publication #48, Ed.: Aletha Rudd, 4-42.

Halverson, M. 2000. IV. Part of the Pig Really Does Fly. The Price We Pay For Corporate Hogs. Institute for Agriculture and Trade Policy. pp. 1-8. Web Site: http://www.iatp.org/hofreport/sec4_r.html.

Ham, J. M. 1999. "Field evaluation of animal-waste lagoons: Seepage rates and subsurface nitrogen transport," in *Effects of Animal Feeding Operations on Water Resources and Environment*. Proceedings of the technical meetings, Fort Collins, Colorado, Aug. 30 – Sep. 1. US Geological Survey Open-File Report 00-24.

Hansen R.C., Keener Harold M., Dick W.A., Marugg C., and Hoitink Harry A.J. 1990. Poultry manure composting. Ammonia capture and aeration control. In *Pap-Am-Soc-Agric-Eng*, No. 90-4062, 19 pp. St. Joseph, Mich: American Society of Agricultural Engineers.

Hantush, M. M., and M. A. Mariño. 2001. "Analytical modeling of the influence of denitrifying sediments on nitrate transport in aquifers with sloping beds." *Water Resour. Res.*, 37(12), 3177-3192.

Health Management and Biosecurity in U. S. Feedlots. Part III. 1999. USDA APHIS. Veterinary Services. Centers for Epidemiology and Animal Health. 555 South Howes St. Ft. Collins, CO 80521.

Hitch, Paul H. 1999. "Trends, technology, and challenges for large-scale animal agriculture," in *Effects of Animal Feeding Operations on Water Resources and the Environment*. Proceedings of the technical meetings, Fort Collins, Colorado, aug. 30 – Sep. 1. US Geological Survey Open-File Report 00-24.

Hitt, Kerie J., Barbra C. Ruddy, and Jeffrey D. Stoner. 1999. "Potential exposure of the nation's waters to animal manure," in *Effects of Animal Feeding Operations on Water Resources and Environment*. Proceedings of the technical meetings, Fort Collins, Colorado, Aug. 30 – Sep. 1. US Geological Survey Open-File Report 00-24.

Hong J.H., Keener Harold M., and Elwell David L. 1998. Preliminary study of the effect of continuous and intermittent aeration on composting hog manure amended with sawdust. *Compost-Science-and-Utilization* 6, no. 3: 74-88.

Hong J.H., Keener Harold M., and Elwell David L. 1998. The effect of continuous and intermittent aeration on composting hog manure amended with sawdust - progress report. ASAE Annual International Meeting, Orlando, Florida, USA, 12-16 July, 1998. 1998, 21 Pp.; ASAE Paper No. 984098.

- Hong J.H., Park K.J., and Shon B.K. 1997. Influence of aeration rate on ammonia emission in high rate composting of dairy manure and rice hulls mixtures. A progress report. In Pap-Am-Soc-Agric-Eng, No. 974114, 8 pp. ASAE Annual International Meeting, St. Joseph, Mich.: American Society of Agricultural Engineers.
- Hong, J. H., J. Matsuda, and Y. Ikeuchi. 1983. High rapid composting of dairy cattle manure with crops and forest residues. *Trans ASAE* 26, no. 2: 533-45.
- Hosek, G., D. Leschinsky, S. Irons, and T. J. Safranek. 1997. Multidrug-resistant *Salmonella* serotypes Typhimurium-United States, 1996. *MMWR Morbid. Mortal, Wkly Rep.* 46:308-310.
- Hurst, C. J., C. P. Gerba, and I. Cech. 1980. "Effects of environmental variables and soil characteristics on virus survival in soil." *Appl. Environ. Microbio.*, 40, 1067-1079.
- Impellitteri, C.A., Y. Lu, J.K. Saxe, H.E. Allen, and W.J.G. M. Peijnenburg. 2002. Correlation of the partitioning of dissolved organic matter fractions with the desorption of Cd, Cu, Ni, Pb, and Zn from 18 Dutch soils. *Environ. Intl.* 28: 401-410.
- Iowa State University. 1995. Land application for effective manure nutrient management. PM-1599, Iowa State Univ. Extension. Ames, Iowa.
- Isbister, J. et al. Ecological Effects of Antibiotics in Runoff from an Eastern Shore Tributary of the Chesapeake Bay. Wilde, F.D., Britton, L.J., Miller, C.V., and Kolpin, D.W., comps., 2000, Effects of animal feeding operations on water resources and the environment—proceedings of the technical meeting, Fort Collins, Colorado, August 30-September 1, 1999: U.S. Geological Survey Open-File Report 00-207, 107p.
- Jacobson, L.D., C. Radman, D. Schmidt, and R. Nicalia. 1997b. Odor measurements from manure storage on Minnesota pig farms. P. 93-100. In: *Proc. TLES*, Bloomington, MN. May 29-31, 1997. Am. Soc. Agric. Engin., St. Joseph, MI.
- Jacobson, L.D., C.J. Clanton, C. Radman, D. Schmidt, R. Nicalia, and K.A. Janni. 1997a. Comparison of hydrogen sulfide and odor emissions from animal manure storages. P. 404-412. In: J.A.M. Voermans and G.J. Monteny (eds). *Proc. Int'l. Symp. Animal and Odor Control from Anima Production Facilities*, Vinkeloord, the Netherlands. Oct. 6-10, 1997, Dutch Soc. Agric. Engin., Vinkeloord, the Netherlands.
- Jawson, M. D., R. J. Wright, and L. W. Smith. 1998. "U.S. Department of Agriculture's national program on manure and byproduct utilization." In *AFO & GW, 1998, Animal Feeding Operations and Ground Water: Issues, Impacts, and Solutions – A Conference for the Future*, St. Louis, Missouri, 1-4.
- Jawson, M.D., L.F. Elliot, K.E. Sexton, and D.H. Fortier. 1982. The effect of cattle grazing on indicator bacteria in runoff from a Pacific northwest watershed. *J. Environ. Qual.* 11:621-627.
- Jorm, L.R., Lightfoot, N.F., Morgan, K.L.(1990), An epidemiological study of an outbreak of Q fever in a secondary school, *Epidemiol Infect* 1990 Jun; 104(3):467-77.
- Joshua, R. S., B. J. Macauley, and H. J. Mitchell. 1998. Characterization of temperature and oxygen profiles in windrow processing systems. *Compost-Science-and-Utilization* 6, no. 4: 15-28.

- Kadlec, R.H. and R.L. Knight. 1996. Treatment Wetlands. CRC Press LLC, Boca Raton, FL.
- Kansas State University Agricultural Experiment Station and Cooperative Extension Service. MF2303, 10/1997. www.oznet.ksu.edu
- Kanwar, R.S., H. P. Johnson, and J. L. Baker. 1983. "Comparison of simulated and measured nitrate losses in tile effluent." *Trans. Am. Soc. Agric. Eng.*, 26, 1451-1457.
- Kasmanian, R.M., and R.F. Ryank. 1996. Agricultural composting in the United States: Trends and driving forces. *Jour. Soil and Water Conservation*. May- June: 194-201.
- Kellogg, R.L., C.H. Lander, D. Moffitt, and N. Gallehan. 2000. Manure nutrients relative to the capacity of cropland and pastureland to assimilate nutrients: spatial and temporal trends for the U.S. U.S. Dept. Agric. Nat. Res. Cons. Serv., Washington D.C.
- Kemp, J. S., E. Paterson, S. M. Gammack, M. S. Cresser, and K. Killham. 1992. "Leaching of genetically modified *Pseudomonas fluorescens* through organic soils: Influence of temperature, soil pH, and roots." *Bio. Fertil. Soil.*, 13, 218-224.
- Kirchmann, H., and E. Witter. 1989. Ammonia volatilization during aerobic and anaerobic manure decomposition. *Plant and Soil* 115: 35-41.
- Klinger, Barbara, "Environmental Aspects of Biogas Technology," *German Biogas Association*.
- Knight, R.L., V.W.E. Payne, R.E. Borer, R.A. Clarke, and J.H. Pries. 2000. Constructed Wetlands for Livestock Wastewater Management. *Ecological Engineering*, Vol. 15, No. 1-2, pp. 41-55, June 2000.
- Kolpin, D., Furlong, E., Meyer, M., Thurman, E., Zaugg, S., Barber, L., and Buxton, H., Pharmaceuticals, Hormones, and Other Organic Wastewater Contaminants in U.S. Streams, 1999-2000: A National Reconnaissance. *Environmental Science & Technology*, vol. 36, No. 6, 2002, pgs1202-1211.
- Kolpin, D., Riley, D., Meyer, M., Weyer, P., and Thurman, E., *Pharm-Chemical Contamination: A Reconnaissance for Antibiotics in Iowa Streams*, 1999.
- Wilde, F.D., Britton,
- Korom, S. F., 1992. "Natural denitrification in the saturated zone: A review." *Water Resour. Res.*, 28, 1657-1668.
- Kovacic, David A., Mark B. David, Lowell E. Gentry, Karen M. Starks, and Richard A. Cooke. 2000. "Effectiveness of constructed wetlands in reducing nitrogen and phosphorous export from agricultural tile drainage." *J. Environ. Qual.*, 29(4), 1262-1274.
- Larney, F., and A. A. Carcamo. 1999. Active vs. passive composting of feedlot cattle manure. In *Manure management '99*, June 22-25, 1999, Saskatoon, SK. Proceedings of a tri-provincial conference on manure management, 400-405. Saskatoon: Saskatchewan Agriculture and Food.

- Larney, Francis J. 1999. Composting: Minimizing losses and maximizing nutrients and value. In Best management practices to protect our soil, water and air. LandWise Inc., Farm Business Management Program, and AAFRD, 42-45.
- Larsen-Royce, E., R.J. Miner, J.C. Buckhouse, and J.A. Moore. 1994. Water-quality benefits of having cattle manure deposited away from streams. *Bioresource Technol.* 48:113-118.
- Lau, A. K., K. V. Lo, P. H. Liao, and J. C. Yu. 1992. Aeration experiments for swine waste composting. *Bioresour-Technol* 41, no. 2: 145-52.
- Lau, A. K., P. H. Liao, and K. V. Lo. 1993. Evaluation of swine waste composting in vertical reactors. *J-Environ-Sci-Health,-Part-A:-Environ-Sci-Eng A28*, no. 4: 761-77.
- Legrand. H. E., V. T. Stringfield. 1973. "Concepts of karst development in relation to interpretation of surface runoff." *U.S. Geol. Surv. Jour. Res.*, V.1, p. 351-360.
- Lemley, Ann. 1987. "U.S.D.A. Research and extension recommendations for groundwater programs." In *Chautauqua Groundwater Workshop for Extension Agents, Chautauqua Institution, Chautauqua, New York, May 7-9, 1986, Publication #48, Ed. Aletha Rudd, 92-98.*
- Liao, P. H., A. T. Vizcarra, A. Chen, and K. V. Lo. 1993. Composting of separated solid swine manure. *J-Environ-Sci-Health,-Part-A:-Environ-Sci-Eng.* 28 , no. 9: 1889-901.
- Lim, Poh-Eng and Mun-Yoon Kiu, 1995. Determination and speciation of heavy metals in sediments of the Juru River, Penang, Malaysia. *Environmental Monitoring and Assessment.* 35:85-95.
- Liu, B.Y., M.A. Nearing, P.J. Shi, and Z.W. Jia. 2000. Slope length effects on soil loss for steep slopes. *Soil Sci. Soc. Am. J.* 64:1759-1763.
- Lopez-Real, J. M., and M. Baptista. 1996. A preliminary comparative study of three manure composting systems and their influence on process parameters and methane emissions. *Compost- Science-and-Utilization* 4, no. 3: 71-82.
- Lufkin, Christopher, Ted Loudon, Michael Kenny, and James Scott. 1996. Windrow methods compared: Practical applications of on-farm composting technology. *BioCycle* 36, no. 12: 76-78.
- Lusk, P., "Methane Recovery from Animal Manures: A Current Opportunities Casebook," 3rd Edition, National Renewable Energy Laboratory, Golden, CO, 1998.
- Lusk, P., and Moser, M., "Anaerobic Digestion – Yesterday, Today, and Tomorrow," Ninth European Bioenergy Conference, Copenhagen, Denmark, UK, June, 1996.
- Lusk, Phillip D., "Latest Progress in Anaerobic Digestion," *BioCycle*, July, 1999, p. 52.
- Lusk, Phillip, "Farm-Based Anaerobic Digestion Practices in the U.S.," <http://www.biogasworks.com/Index/US%20Farm-Based%20AD%20Practices.htm>.

- MacKenzie, W.R., Hoxier, N.J. et al 1994. Massive waterborne outbreak of *Cryptosporidium* infection associated with a filtered water supply. *N. Engl. J Med.* 331:161-167.
- Magbanua, B.S. and Adams, T.T., “Anaerobic Codigestion of Hog and Poultry Waste,” *Bioresource Technology*, 2000.
- Maguire, R.O., J.T. Sims, and F.J. Coale. 2000. Phosphorus fractionation in biosolids-amended-soils: relationship to soluble and desorbable phosphorus. *Soil Sci. Soc. Am. J.* 64: 2018-2024.
- Martinez, J. and Peu, P., 2000. Nutrient fluxes from a soil treatment process for pig slurry. *Soil Use and Management.* 16:100-107.
- Mathur, S. P., N. K. Patni, and M. P. Levesque. 1990. Static pile passive aeration composting of manure slurries using peat as a bulking agent. *Biological Wastes* 34, no. 4: 323-34.
- Mawdsley, J. L., R. D. Bardgett, R. J. Merry, B. F. Pain, and M. K. Theodorou. 1995. “Pathogens in livestock waste, their potential for movement through soil and environmental pollution.” *Applied Soil Ecology*, 2, 1-15.
- Maynard, A. A. 1993. Nitrate Leaching From Compost-Amended Soils.
- McCoy, E. L., and C. Hagedorn. 1979. “Quantitatively tracing bacterial transport in saturated soil systems.” *Water Air Pollut.*, 11, 467-479.
- McBride, M.B. 1994. Trace and toxic elements in soils. In: *Environmental Chemistry of Soils*. Pp. 308-341. Oxford Univ. Press, New York, NY.
- McDowell, R. W., and A. N. Sharpley. 2001. “Approximating phosphorus release from soils to surface runoff and subsurface drainage.” *J. Environ. Qual.*, 30, 508-520.
- McGreer, A.J. 1998. Agricultural Antibiotics and Resistance in Human Pathogens: Villain or Scapegoat? *Can. Med. Assoc. J.*, Nov 3. 159(9): 1119-1120.
- McMurry, S. W., M. S. Coyne, and E. Perfect. 1998. “Fecal coliform transport through intact soil blocks amended with poultry manure.” *J. Environ. Qual.*, 27, 86-92.
- McNeil Technologies, Inc., “Assessment of Biogas-to-Energy Generation Opportunities at Commercial Swine Operations in Colorado, Department of Energy, Western Regional Biomass Energy Program, Nov., 2000.
- Mengis, M., S. L. Schiff, M. Harris, M. C. English, R. Aravena, R. J. Elgood, and A. MacLean. 1999. “Multiple geochemical and isotopic approaches for assessing groundwater NO₃- elimination in riparian zones.” *Ground Water*, 37(3), 448-457.
- Merchant, J.A., M.D., Dr.P.H., Dean, and Ross, R.F., D.V.M., Ph.D. 2002. Iowa Concentrated Animal Feeding Operations: Air Quality Study: Final Report. Iowa State University and The University of Iowa Study Group. pp.1-221.

Midwest Plan Service (MWPS)/Livestock and Poultry Environmental Stewardship Curriculum (LPES). Lessons 40-44. Web Site: http://www.lpes.org/Lessons/Lesson01/01_sec5.pdf

Mielke, L. N., and J. R. Ellis. 1976. "Nitrogen in soil cores and ground water under abandoned cattle feedlots." *J. Environ. Qual.*, 5(1), 71-74.

Millard, Peter S., K.F. Gensheimer, et al. 1994. An Outbreak of *Cryptosporidium* from Fresh-Pressed Apple Cider. *Journal of the American Medical Association*, 272:1592-6.

L.J., Miller, C.V., and Kolpin, D.W., comps., 2000, Effects of animal feeding operations on water resources and the environment—proceedings of the technical meeting, Fort Collins, Colorado, August 30-September 1, 1999: U.S. Geological Survey Open-File Report 00-207, 107p.

Mohanna, C. and Y. Nys, 1999. Effect of dietary zinc content and sources on the growth, body zinc deposition and retention, zinc excretion and immune response in chickens. *British Poultry Science*. 40:108-114.

Morgan GM, Newman C, Palmer SR, Allen JB, Shepherd W, Rampling AM, Warren RE, Gross RJ, Scotland SM, Smith HR. (1998). First recognized community outbreak of haemorrhagic colitis due to verotoxin-producing *Escherichia coli* O 157 H7 in the UK. *Epidemiology and Infection* 101(1):83-91

Morrow, W., P. O'Quinn, J. Barker, G. Erickson, K. Post and M. McGraw. 1995. Composting as a suitable technique for managing swine mortalities. *Swine Health and Production*. 56-68.

Moser, Mark A. et. al., "AgSTAR Program: Benefits, Costs and Operating Experience at Seven New Agricultural Anaerobic Digesters," Oct., 2000. <http://www.epa.gov/outreach/agstar/library/ben.html>

Moser, Mark A., Mattocks, Richard P., "Benefits, Costs and Operating Experience at Ten Agricultural Anaerobic Digesters," Proceedings of the Eighth, Des Moines, IA Oct. 9-12, 2000.

Myers, D. N. 1999. "Methods of assessing microbial contamination of surface and ground waters by animal feeding operations." In *Effects of Animal Feeding Operations on Water Resources and the Environment*. Proceedings of the technical meetings, Fort Collins, Colorado, Aug. 30 – Sep. 1. US Geological Survey Open-File Report 00-24.

Nebraska Department of Environmental Quality. 2001. Environmental Fact Sheet, Air Pollutant Information. Lincoln, NE. Web Site: www.deq.state.ne.us.

Nelson, Hillary. 1997. The Contamination of Organic Produce by Human Pathogens in Animal Manure. Ecological Agriculture Projects web site, <http://www.eap.mcgill.ca/SFMC-1.htm>.

Nicholson, F. A., et al, 1999. Heavy metal contents of livestock feeds and animal manures in England and Wales. *Bioresource Technology*. 70:23-31.

North Carolina (State of). Administrative Code 15A NCAC 2H.0200 (Waste Not Discharged to Surface Waters), Department of Environment, Health and Natural Resources, Division of Water Quality, 1996.

Ohio State University Bulletin, 1998. Tri-State Swine Nutrition Guide. Bulletin 869-98.

Opperman, M. H., L. McBain, and M. Wood. 1987. "Movement of cattle slurry through soil by *Eisenia foetida* (Savigny). *Soil Biol. Biochem.*, 19, 741-745.

Overcash, M. R., F. J. Humenik, and J. R. Miner. 1983. "Livestock Waste Management." Vol. I. CRC Press, Inc., Boca Raton, Florida.

Øygarden, L., J. Kvaerner, and P. D. Jenssen. 1977. "Soil erosion via preferential flow to drainage systems in clay soils." *Geoderma*, 76, 65-86.

Parker, D. B., D. D. Schulte, D. E. Eisenhauer. 1999. "Seepage from earthen animal waste ponds and lagoons – An overview of research results and state regulations." *American Society of Agricultural Engineers, Transactions of the ASAE*, 42(2), 485-493.

Patania, N.L., J.G. Jacangelo, L. Cummings, A. Wilezak, K. Riley, and J. Oppenheimer. 1995. Optimization of filtration for cyst removal. AWWARF and AWWA Ann. Mtgs. Denver, CO.

Patni, N.K., H.R. Toxopeus, and P.Y. jui. 1985. Bacterial quality of runoff from manured and non-manured cropland. *Trans. Amer. Soc. Agric. Eng.* 28: 1871-1877.

Patni, N.K., R. Toxopeus, A.D. Tennant, and F.R. Hore. 1984. Bacterial quality of tile drainage from manured and fertilized cropland. *Water Res.* 18: 127-132.

Payne Engineering and CH2M-Hill. 1997. *Constructed Wetlands for Animal Waste Treatment: A Manual on Performance, Design, and Operation With Case Histories.* CH2M-Hill, Gainesville, FL, June 1997. (EPA 855-B97-001)

Pell, A. 1997. Manure and microbes: public and animal health problem? *J. Dairy Sci.* 80:2673-2681.

Penprase, M. Antibiotics found in Shoal Creek, *Springfield News-Leader*, December 26, 2001.

Pesti, G. M. et al, 1996. Studies on the feeding of cupric sulfate pentahydrate and cupric citrate to broiler chickens. *Poultry Science.* 75 (#9):1086-1091.

Petersen, S. O., A-M Lind, and S. G. Sommer. 1998. Nitrogen and organic matter losses during storage of cattle and pig manure. *Journal of Agricultural Science Cambridge* 130, no. 69-79.

Prairie Agricultural Machinery Institute, *A Guide to Swine Manure Management Methods*, Humboldt, Saskatchewan, Canada, April 1997. <http://www.pami.ca/PDGs/Pami730.pdf>

Price, J, 1975. The availability to sheep of copper in pig-slurry and slurry-dressed herbage. *Proceedings of the Nutrition Society.* 34 (#1):9A-10A.

Public Health Dispatch: Outbreak of *Escherichia coli* O157:H7 and *Campylobacter* Among Attendees of the Washington County Fair–New York, 1999.

- Randall, G. W., J. K. Iragavarapu, and M. A. Scmitt. 2000. "Nutrient Losses in subsurface drainage water from dairy manure and urea applied to corn." *J. Environ. Qual.*, 29, 1244-1252.
- Reed, S.C., R.W. Crites, and J.E. Middlebrooks. 1995. *Natural Systems for Waste Management and Treatment*. 2nd edition. McGraw-Hill, Inc., New York, NY.
- Reed, St. T., et al, 1993. Copper fractions extracted by Mehlich-3 from soils amended with either CuSO₄ or copper rich pig manure. *Commun. Soil Sci. Plant Anal.* 24(#9 and 10):827-839.
- Reintjes R, Hellenbrand W, Dusterhaus A. (2000) Q-fever outbreak in Dortmund in the summer of 1999. Results of an epidemiological outbreak study *Gesundheitswesen*. 2000 Nov;62(11):609-14.[Article in German]Gesundheitsamt der Stadt Dortmund. ralf.reintjes@loegd.nrw.de
- Report to the State of Iowa Department of Public Health on the Investigation of the Chemical and Microbial Constituents of Ground and Surface Water Proximal to Large-Scale Swine Operations, 1998.
- Richardson, A.J., Frandenberg, R.A., et al. An outbreak of waterborne cryptosporidiosis in Swindon and Oxfordshire. *Epidemiol. Infect.* 107:485-495. 1991.
- Ritter, W. F., A. E. M. Chirnside. 1990. "Impact of animal waste lagoons on groundwater quality." *Biological Wastes*, 34:39-54.
- Robens, J. 1998. "Research needs to prevent ground water contamination from animal feeding operations." *In AFO & GW, 1998, Animal Feeding Operations and Ground Water: Issues, Impacts, and Solutions – A Conference for the Future*, St. Louis, Missouri, 105-107
- Robertson, John B., and Stephen C. Edberg. 1977. "Natural protection of springs and well drinking water against surface microbial contamination: I. Hydrogeologic parameters." *Critical Reviews in Microbiology*, 23(2), 143-178.
- Rochette, P., E. van Bochove, D. Prévost, D.A. Angers, D. Côté, and N. Bertrand. 2000. soil carbon and nitrogen dynamics following application of pig slurry for the 19th consecutive year: II. Nitrous oxide fluxes and mineral nitrogen. *Soil Sci. Soc. Am. J.* 64: 1396-1403.
- Rosen, Barry H. 2000. "Waterborne pathogens in agricultural watersheds," *NRCS, Watershed Science Institute, School of Natural Resources, University of Vermont, Burlington*.
- Rothe, S., et al, 1994. The effect of vitamin C and zinc on the copper-induced increase of cadmium residues in swine. *Zeitschrift Fur Ernährungswissenschaft.* 33(#1):61-67.
- Russ, C.F. and Yanko, W.A. 1981. Factors affecting salmonella repopulation in composted sludges. *Appl. Environ. Microbiol.* 41:597-602.
- Ryden, J. C., J. K. Syers, and R. F. Harris. 1973. "Phosphorus in runoff and streams." *Adv. Agron.*, 25, 1-45.
- Rynk, Robert F. 1992. *On-farm composting handbook.*, NRAES-54. Ithaca, NY: Northeast Regional Agricultural Engineering Service.

Saele, Leland M., "Anaerobic Digester Lagoon with Methane Gas Recovery: First Year Management and Economics," Conservation Technology Information Center, Purdue University.

<http://www.ctic.purdue.edu/core4/nutrient/manuremgmt/Paper31.html>, Aug. 7, 2001

Saint-Fort, R., R. M. Raina, and B. Prescott. 1995. "Subsurface quality under a cattle feedlot and adjacent cropfield." *J. Environ. Sci. Health*, A 30(3), 637-650.

Sartaj, M., L. Fernandes, and N. K. Patni. 1997. Performance of forced, passive, and natural aeration methods for composting manure slurries. *Trans-ASAE* 40, no. 2: 457-63.

Scapegoat? *Canadian Medical Association Journal*, Nov 3, 1998, 159(9) pp 1119-1120.

Schepers, J. S., and D. D. Francis. 1998. "Manure characterization and nutrient utilization strategies for crops to minimize environmental risk." In *AFO & GW, 1998, Animal Feeding Operations and Ground Water: Issues, Impacts, and Solutions – A Conference for the Future*, St. Louis, Missouri. 96-104.

Sharpe, R.R. and L.A. Harper. 1997. Ammonia and nitrous oxide emissions from sprinkler irrigation applications of swine effluent. *J. Environ. Qual.* 26: 1703-1706.

Sharpley, A., W. Gburek, and G. Folmar. 1998. "Integrated Phosphorus and Nitrogen Management in Animal Feeding Operations for Water Quality Protection." In *AFO & GW, 1998, Animal Feeding Operations and Ground Water: Issues, Impacts, and Solutions – A Conference for the Future*, St. Louis, Missouri. 72-95.

Shipitalo, M.J. and F. Gibbs. 2000. Potential of earthworm burrows to transmit injected animal wastes to tile drains. *Soil Sci. Soc. Am. J.* 64: 2103-2109.

Siddique, M. T., J. S. Robinson, and B. J. Alloway. 2000. "Phosphorus reactions and leaching potential in soils amended with sewage sludge." *J. Environ. Qual.*, 29(6), 1931-1938.

Simpson, T. W. 1990. Agronomic use of poultry industry waste. *Poultry Sci.* 70:1126-1131.

Sims, J. T., R. R. Simard, and B. C. Joern. 1998. "Phosphorus loss in agricultural drainage: Historical perspective and current research." *J. Environ. Qual.*, 27, 277-293.

Smith, M.S., G.W. Thomas, R.E. White, and D. Ritanga. 1985. Transport of *Escherichia coli* through intact and disturbed soil columns. *J. Environ. Qual.* 14: 87-91.

Spencer, J. L., H. Dinel, N. K. Patni, and J. R. Chambers. 1997. Composting strategies to improve biosecurity and eliminate Salmonella from chicken litter. In: *Proceedings seventh annual conference, exhibits & general meeting, November 5-7, 1997, Montreal, Quebec Composting Council of Canada*, 277-82. Toronto: The Composting Council of Canada.

Spruill, T. B. 1999. "Identification of sources of nitrate in ground water – A feasibility evaluation." In *Effects of Animal Feeding Operations on Water Resources and the Environment*. Proceedings of the

technical meetings, Fort Collins, Colorado, Aug. 30 – Sep. 1. US Geological Survey Open-File Report 00-24.

Steiner, C.G., “Understanding Anaerobic Treatment,” *Pollution Engineering Online*, Feb., 2000.
<http://www.pollutionengineering.com/archives/2000/pol0201.00/pol0200c2583.htm>

Stentiford, E.I. 1993. Diversity of Composting Systems. p. 95-110. *In* H.A.J. Hoitink and H.M. Keener (ed) *Science and Engineering of Composting: Design, Environmental, Microbiological and Utilization Aspects*. Renaissance Publ., Worthington, OH

Stevens, R.S. and R.J. Laughlin. 2001. Cattle slurry affects nitrous oxide and dinitrogen emissions from fertilizer nitrate. *Soil Sci. Soc. Am. J.* 65: 1307-1314.

Stoddard, C.S., M.S. Coyne, and J. H. Grove. 1998. Fecal bacterial survival and infiltration through a shallow agricultural soil: timing and tillage effects. *J. Environ. Qual.* 27: 1516-1523.

Sweeten, J. M. 1991. “Groundwater Quality Protection for Livestock Operations.” Texas Agricultural Service.

Sweeten, J.M. 2001. Animal Production and Air Quality. Agricultural Outlook Forum. Web Site:
<http://www.usda.gov>.

Sweeten, J.M., Erickson, L., Woodford, P., Parnell, C.B., Thu, K., Coleman, T., Flocchini, R., Reeder, C., Master, J.R., Hambleton, W., Bluhm, G., Tristao, D. 2000. Air Quality Research and Technology Transfer White Paper and Recommendations for Concentrated Animal Feeding Operations. Washington, DC. Web Site: <http://www.nhq.nrcs.usda.gov/faca/Policies/CAFO.html>

Tester, C.F. 1990. Organic amendment effects on physical and chemical properties of a sandy soil. *Soil Science Society of America Journal* 54:827-831.

Thu, K.M., Ph.D. 2001. Neighbor Health and Large-Scale Swine Production. *In*: An Agricultural Safety and Health Conference: Using Past and Present to May Future Action. National Coalition for Agricultural Safety and Health. Iowa City, IA. pp. 1-5. Web Site:
http://www.uic.edu/sph/glakes/agsafety2001/papers/kendall_thu.htm.

Tiquia, S. M. 1999 Composting of spent pig litter in turned and forced-aerated piles. *Environmental Pollution* 99, no. 3: 329-37.

Tiquia, S. M., Tam N.F.Y., and I. J. Hodgkiss. 1997. Effects of bacterial inoculum and moisture adjustment on composting of pig manure. *Environmental Pollution* 96, no. 2: 161-71.

Tiquia, S.M, and Tam N.F.Y. 1998. Salmonella elimination during composting of spent pig litter. *Bioresour-Technol* 63, no. 2: 193-96.

Tom-Petersen, A., Hosbond, C., Nybroe, O., 2001. Identification of copper-induced genes in *Pseudomonas fluorescens* and use of a reporter strain to monitor bioavailable copper in soil. *FEMS Microbiology Ecology*. 38(#1);59-67.

United States Department of Agriculture (USDA)/Agriculture Research Service (ARS). ARS National Programs. Manure and Byproduct Utilization. Action Plan: Component I: Atmospheric Emissions. Beltsville, MD. Web Site: <http://www.nps.ars.usda.gov...rams/programs.htm?npnumber=206&docid=344>.

United States Department of Agriculture. 1979. Animal Waste Utilization on Cropland and Pastureland; Utilization Research Report No. 6. Science and Education Administration, Washington D.C.

United States Department of Agriculture. 1991. Constructed Wetlands for Agricultural Wastewater Treatment. USDA Natural Resources Conservation Service, Washington, DC.

United States Department of Agriculture. 1995. Handbook of Constructed Wetlands, 5 volumes. USDA Natural Resources Conservation Service/USEPA Region III/Pennsylvania Department of Natural Resources, Washington, DC.

United States Department of Agriculture. 1996. NRCS. National Engineering Handbook: Agricultural Waste Management Field Handbook. U.S. Dept. Commerce, NTIS. Springfield, VA.

United States Department of Agriculture. NRCS. 1998. Nutrients available from livestock manure relative to crop growth requirements. USDA-NRCS. Washington D.C.

United States Environmental Protection Agency, "*Aerobic Treatment of Livestock Wastes*," 1972.

USDA. 1994. *Escherichia coli* O157:H7 Issues and ramifications., USDA:APHIS:VS Centers for Epidemiology and Animal Health, Fort Collins, CO.

USDA. 2000. "Principal Pathogens of Concern. Cryptosporidium and Giardia." *Waterborne Pathogen Information Sheet*. June.

United States Environmental Protection Agency, 2001. Ammonia Emission Factors from Swine Finishing Operations. Research Triangle Park, NC. Web Site: <http://www.epa.gov/ORD/NRMRL/Pubs/2001/600a01037.htm>.

United States Environmental Protection Agency, *AgSTAR Program: Guide to Operational Systems*, Mar., 2001. <http://www.epa.gov/outreach/agstar/operation/index.html>

United States Environmental Protection Agency, *AgSTAR Program: USDA-NRCS Biogas Interim Standards*, March, 2001. http://www.epa.gov/outreach/agstar/stand_plug.html.

United States Environmental Protection Agency. 1999. North American Treatment Wetland Database v2.0. R.H. Kadlec, R.L. Knight, S.C. Reed, and R.W. Ruble, eds. Office of Water, Washington, DC. (Available from Don Brown, USEPA, Cincinnati, OH, 513-569-7630.)

United States Environmental Protection Agency. 2000a. Manual: Constructed Wetlands Treatment of Municipal Wastewaters. Office of Research and Development, Cincinnati, OH, September 2000. (EPA 625-R-99-010.

United States Environmental Protection Agency. 2000b. Guiding Principles for Constructed Treatment Wetlands: Providing Water Quality and Wildlife Habitat. Office of Wetlands, Oceans and Watersheds, Washington, DC, October 2000. (EPA 843-B-00-003. www.epa.gov/owow/wetlands/constructed/guide.html)

United States Environmental Protection Agency. 2001. Development Document for the Proposed Revisions to the National Pollutant Discharge Elimination System Regulation and the Effluent Guidelines for Concentrated Animal Feeding Operation. Office of Water, Washington, DC, January 2001. (EPA 821-R-01-003. www.epa.gov/ost/guide/cafo/devdoc.html)

USEPA, 2001, Draft Proceedings of the Workshop on Emerging Infectious Disease Agents and Issues Associated with Animal Manures, Biosolids and Other Similar By-Products, Vernon-Manor Hotel in Cincinnati, Ohio; June 4-6, 2001

USEPA. 1998. *Environmental Impacts of Animal Feeding Operations*, U.S. Environmental Protection Agency, Office of Water, Standards and Applied Sciences Division, Washington, D.C. 20460, December 31, 1998.

USEPA. 2000. "National Management Measures to Control Nonpoint Source Pollution from Agriculture." Office of Water, Nonpoint Source Control Branch. Draft Report.

USEPA. 2003. Industry Directory for On-Farm Biogas Recovery Systems, Second Edition. Office of Air and Radiation, USEPA, Washington, D.C. EPA-430-R-03-001.

University of Georgia College of Agricultural and Environmental Sciences Cooperative Extension Service. Livestock Newsletter, January-February, 1998.

Valcour, J. E., P. Michel, S. A. McEwen, and J. B. Wilson, Associations between Indicators of Livestock Farming Intensity and Incidence of Human Shiga Toxin-Producing *Escherichia coli* Infection, *Emerging Infectious Diseases*, Vol. 8, No. 3, March 2002 pp. 252-257

Varel, V.H. 2001. Livestock Manure Odor Abatement with Plant-Derived Oils and Nitrogen Conservation With Urease Inhibitors. USDA-ARS, U.S. Meat Animal Research Center. Clay Center, NE. Web Site: <http://www.fass.org/fass01/pdfs/varel.pdf>.

Vuorinen, Arja H., and M. H. Saharinen. 1997. Evolution of microbiological and chemical parameters during manure and straw co-composting in a drum composting system. *Agric-Ecosyst-Environ* 66, no. 1: 19-29.

Weidner, R.B., A.G. Christianson, S.R. Weibel, and G.G. Robeck. 1969. Rural runoff as a factor in stream pollution. *J. Water Pollut. Contr. Fed.* 41:377-384.

WHO, Health Guidelines for the Use of Wastewater in Agriculture and Aquaculture, Report of a WHO Scientific Group, World Health Organization, Geneva, WHO Technical Report Series, No. 778, 1989.

Wisconsin Energy Bureau, Department of Administration, "Turning Manure to Energy on Farms, Madison, WI, <http://www.wifocusonenergy.com/renewable/manure.pdf>

Withers, P. J. A., and S. C. Jarvis. 1998. "Mitigating options for diffuse phosphorus loss to water." *Soil Use Manage.*, 10, 348-354.

Wolf, D.C., J.T. Gilmour, and P.M. Gale. 1988. Estimating potential ground and surface water pollution from land application of poultry litter. II. Publ. No. 137. Arkansas Water Resources Research Center, Fayetteville, AR. Web Site: www.epa.gov/ordntrnt/ORD/NRMRL/Pubs/2001/wetlands/625r99010.pdf)

World Animal Sciences, 1987. Animal Production and Environmental Health, B6, Chapter 5, 154-202.

Yale Center for Environmental Law and Policy. Controlling Odor and Gaseous Emission Problems from Industrial Swine Facilities: A Handbook for All Interested Parties. pp.1-14 . Web Site: <http://www.yale.edu/envirocenter/clinic/swine/swine.html>.

Young, R.A., T. Huntrods, and W. Anderson. 1980. Effectiveness of vegetated buffer strips in controlling pollution from feedlot runoff. *J. Environ. Qual.* 9: 483-487.

Zahn, J.A., DiSpirito, A.A., Do, Y.S., Brooks, B.E., Cooper, E.E., and Hatfield, J.L. 2001. Correlation of Human Olfactory Responses to Airborne Concentrations of Malodorous Volatile Organic Compounds Emitted from Swine Effluent. *J. Environ. Qual.* 30:624-634.

Zahn, J.A., Hatfield, J.L., Do, Y.S., DiSpirito, A.A., Laird, D.A., and Pfeiffer, R.L. 1997. Characterization of Volatile Organic Emissions and Wastes from a Swine Production Facility. *J. Environ. Qual.* 26:1687-1696.